

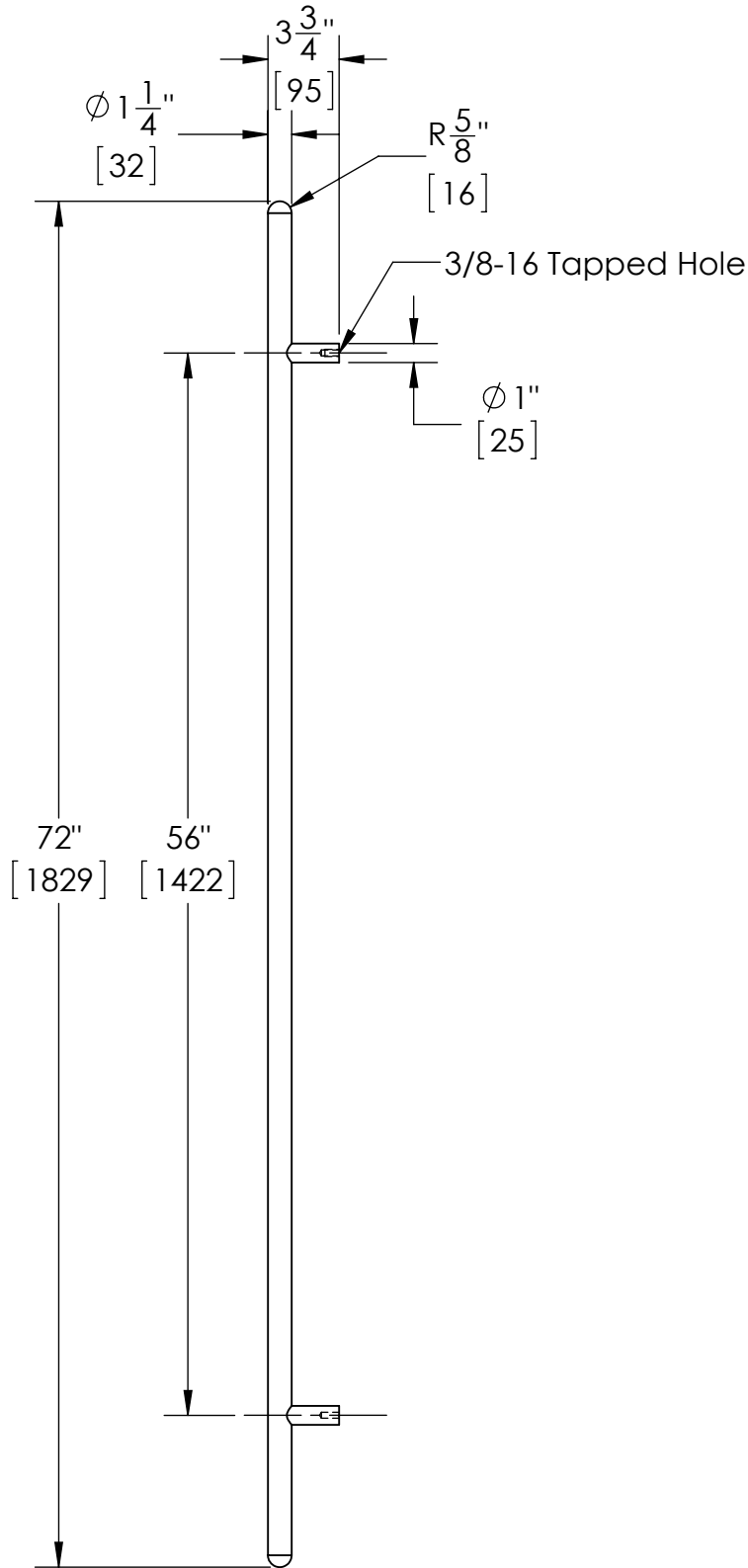

| REV. | DESCRIPTION | DATE |
|------|------------------|-----------|
| - | INITIAL CHECK IN | 1/16/2014 |



NOTE: (2) 3/8-16 x 2-1/4" FPHMS w/ Finish Washers Supplied Standard
 DIMENSIONS IN [] ARE IN MILLIMETERS

| | | | | | | |
|--|--|----------------------|---------------|--|---|---|
|  PROPRIETARY & CONFIDENTIAL THE INFORMATION CONTAINED IN THIS DRAWING IS THE SOLE PROPERTY OF HAGER COMPANIES. ANY REPRODUCTION IN PART OR AS A WHOLE WITHOUT THE WRITTEN PERMISSION OF HAGER COMPANIES IS PROHIBITED. | HAGER RESERVES THE RIGHT TO MAKE DESIGN CHANGES WITHOUT NOTICE. CALL HAGER ENGINEERING AT 1-800-325-9995 FOR THE LATEST REVISION DATE OF TEMPLATE. | DRAWN | MRJ | 12/21/2010 | 915P STRAIGHT MOUNTING VERTICAL PULL (72" OVERALL) | |
| | | MATERIAL | AISI 304 | ENG. APPR. | | - |
| | | FINISH | - | Q.A. | | - |
| | | DO NOT SCALE DRAWING | | TOLERANCES: FRACTIONAL: ±0.015" ANGULAR: MACH: ± 1° BEND: ±1° TWO PLACE DECIMAL: ±0.01" THREE PLACE DECIMAL: ±0.004" | | |
| | | SIZE | DWG. NO. | | REV. | |
| | | A | S-TA00816 | | - | |
| | | SCALE: 1:16 | WEIGHT: 26.51 | | SHEET 1 OF 2 | |

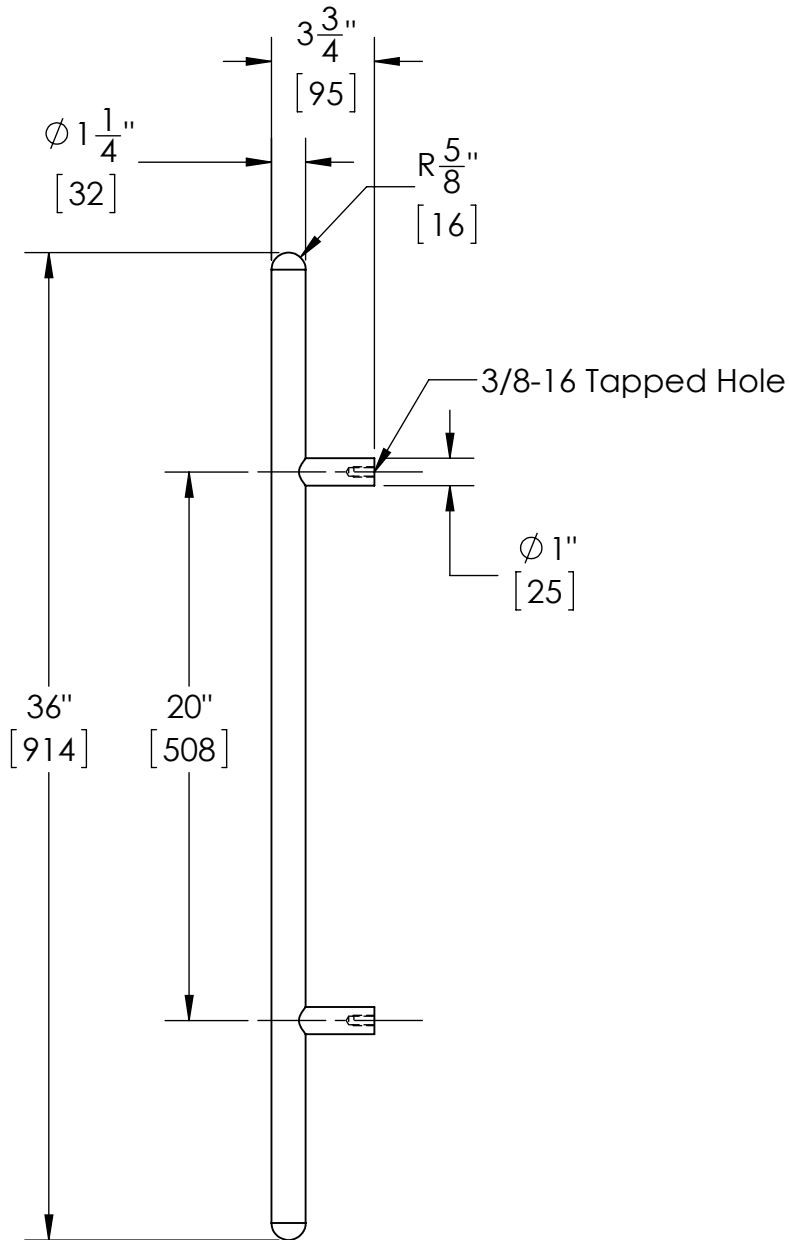

NOTES: (2) 3/8" -16 x 2-1/4" FPHMS w/Finish Washers Supplied Standard

DIMENSIONS IN [] ARE IN MILLIMETERS

| | | | | | | | | | | | | |
|--|--|-------------|--------------|--------------|---|----------------------|--|---|--|------------------|------------------------------|-----------|
|  PROPRIETARY & CONFIDENTIAL THE INFORMATION CONTAINED IN THIS DRAWING IS THE SOLE PROPERTY OF HAGER COMPANIES. ANY REPRODUCTION IN PART OR AS A WHOLE WITHOUT THE WRITTEN PERMISSION OF HAGER COMPANIES IS PROHIBITED. | HAGER RESERVES THE RIGHT TO MAKE DESIGN CHANGES WITHOUT NOTICE. CALL HAGER ENGINEERING AT 1-800-325-9995 FOR THE LATEST REVISION DATE OF TEMPLATE. | MATERIAL | AISI 304 | FINISH | - | DO NOT SCALE DRAWING | DRAWN MRJ 12/21/2010 ENG. APPR. - - Q.A. - - TOLERANCES: FRACTIONAL: ±0.015" ANGULAR: MACH: ± 1° BEND: ±1° TWO PLACE DECIMAL: ±0.01" THREE PLACE DECIMAL: ±0.004" | 915P STRAIGHT MOUNTING VERTICAL PULL (36" OVERALL) | | SIZE A | DWG. NO. S-TA00816 | REV. - |
| | | SCALE: 1:16 | WEIGHT: 1.72 | SHEET 2 OF 2 | | | | | | | | |