

# ENTRE//MATIC

## DITEC HA9 LOW ENERGY SWING OPERATOR

### Installation & Instruction Manual

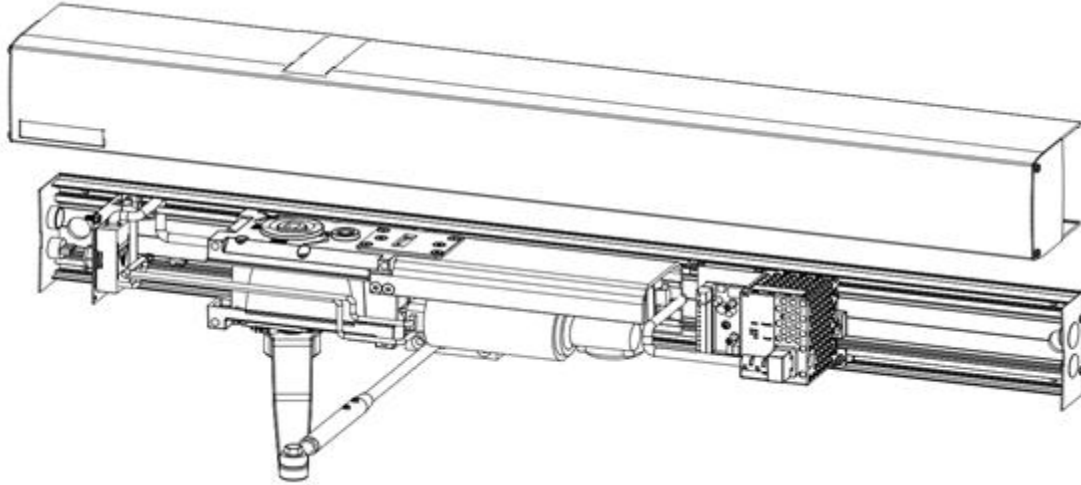

**READ AND FOLLOW ALL INSTALLATION INSTRUCTIONS CAREFULLY!  
FAILURE TO DO SO MAY RESULT IN PERSONAL INJURY OR PROPERTY DAMAGE!**

- This product is to be installed on the interior side of the door.
- Install only on a properly operating and balanced door. A door that is operating improperly could cause severe injury. Before installing the operator, have qualified service personnel make repairs to cables, and other hardware.
- Before installing the operator, remove or make inoperative, all locks (unless mechanically and/or electrically interlocked to the power unit), all activation units and accessories that may be connected to the door.
- A commercial/industrial door operator that has exposed moving parts capable of causing injury to persons or employs a motor deemed indirectly accessible by virtue of its location above the floor shall include:
  - Install the door operator at least 2.4m (8ft) or more above the floor, and/or
  - If the operator must be installed less than 2.4m (8ft) above the floor, then exposed moving parts must be protected by covers or guarding provided by the operator manufacturer.
- The control unit **MUST** be located: (1) within the sight of the door, and (2) at a minimum height of 1.5m (5ft) above the floors, landings, steps, or any other adjacent walking surface and (3) away from all moving parts of the door.
- Install the Entrapment Warning Placard next to the control station in a prominent location if applicable.
- To reduce the risk of injury to persons - Use this system only with pedestrian doors.
- Do not connect the operator to a power supply until instructed to do so. Connection of the high voltage supply should be done by a qualified professional and within the guidelines of the enforced local electrical codes.
- **HIGH VOLTAGE (INCOMING 115 VAC) WIRES AND LOW VOLTAGE WIRES CANNOT SHARE THE SAME ACCESS HOLE. HIGH VOLTAGE WIRES MUST BE ROUTED AND SECURED AWAY FROM ALL LOW VOLTAGE WIRES.**

(THIS PAGE IS INTENTIONALLY BLANK)

<b>1.0 GENERAL INFORMATION</b>	<b>4</b>	<b>6.0 ACTIVATION UNITS &amp; ACC</b>	<b>45</b>
1.1 Typical Installation Flow Chart		6.1 Connection of Activation Units and Accessories	
1.2 Completed/Typical Automatic Door Installation		6.2 Adjusting Parameters	
1.3 Replacement Parts			
1.4 Important Information		<b>7.0 ADVANCED SETTINGS</b>	<b>47</b>
1.5 Compliance Codes and Standards		7.1 Overhead Presence Detection (OPD)	
1.6 Technical Specification		7.2 Lock Kick	
1.7 How HA9 Works		7.3 Lock Unlock	
1.8 Controller Unit HA9 Functions			
1.9 Extension Unit EXU-SI Functions		<b>8.0 INSTALLATION WRAP UP</b>	<b>49</b>
1.10 Extension Unit EXU-SA Functions		8.1 Additional Sensors/Knowing Act Devices	
1.11 Consideration Of Surroundings		8.2 Header Cover Installation	
1.12 Before Installation		8.3 Safety Decals	
1.13 Operator Type And Handing		8.4 Safety Sticker Placement Example	
<b>2.0 OPERATOR INSTALLATION</b>	<b>17</b>		
2.1 Pre-Mounting Header Box Instructions		<b>9.0 TROUBLESHOOTING</b>	<b>52</b>
2.2 Push Header Installation		9.1 Common Faults	
2.3 Pull Header Installation		9.2 Error Indication	
2.4 Double Egress Header			
2.5 Electrical Connection		<b>10.0 SERVICE/MAINTENANCE</b>	<b>54</b>
2.6 Change Configuration		10.1 Service/Maintenance	
2.7 Motor/Gearbox Reinstallation			
<b>3.0 ARM INSTALLATION</b>	<b>26</b>	<b>11.0 MANUFACTURER</b>	<b>55</b>
3.1 Push Arm Components and Configurations		11.1 Manufacturer Information	
3.2 Push Arm Installation			
3.3 Pull Arm Installation			
<b>4.0 CONTROL UNITS</b>	<b>33</b>		
4.1 HA9 Control			
4.2 Extension Units			
4.3 Extension Units EXU-SI			
4.4 Extension Units EXU-SA			
<b>5.0 OPERATOR TUNING</b>	<b>37</b>		
5.1 Back Check and Latch Adjustment (Door Stop)			
5.2 Micro Switch			
5.3 Sync Cable for Double Doors			
5.4 Auto-Learn (Back Check and Latch Check)			
5.5 One/Two Push LRN Button Function			
5.6 LRN Button for Double Doors			
5.7 LRN with Advanced Settings			
5.8 Revert To Default Values "Back and Check"			
5.9 General Adjustment			
5.10 Reducing/Increasing "Spring Pre-Tension" (SPTE)			

## 1.1 Typical Installation Flow Chart

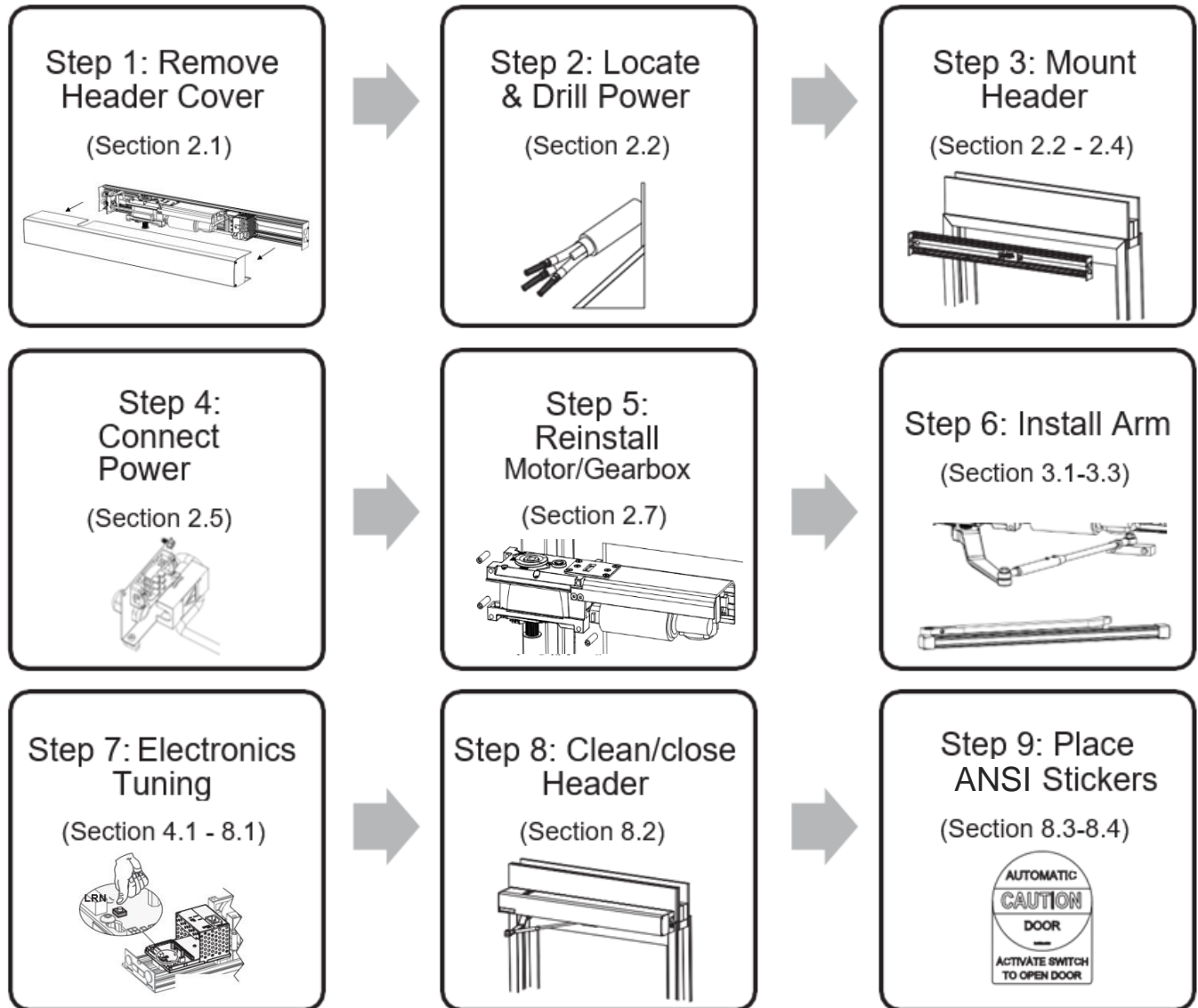

## 1.2 Completed/Typical Automatic Door Installation

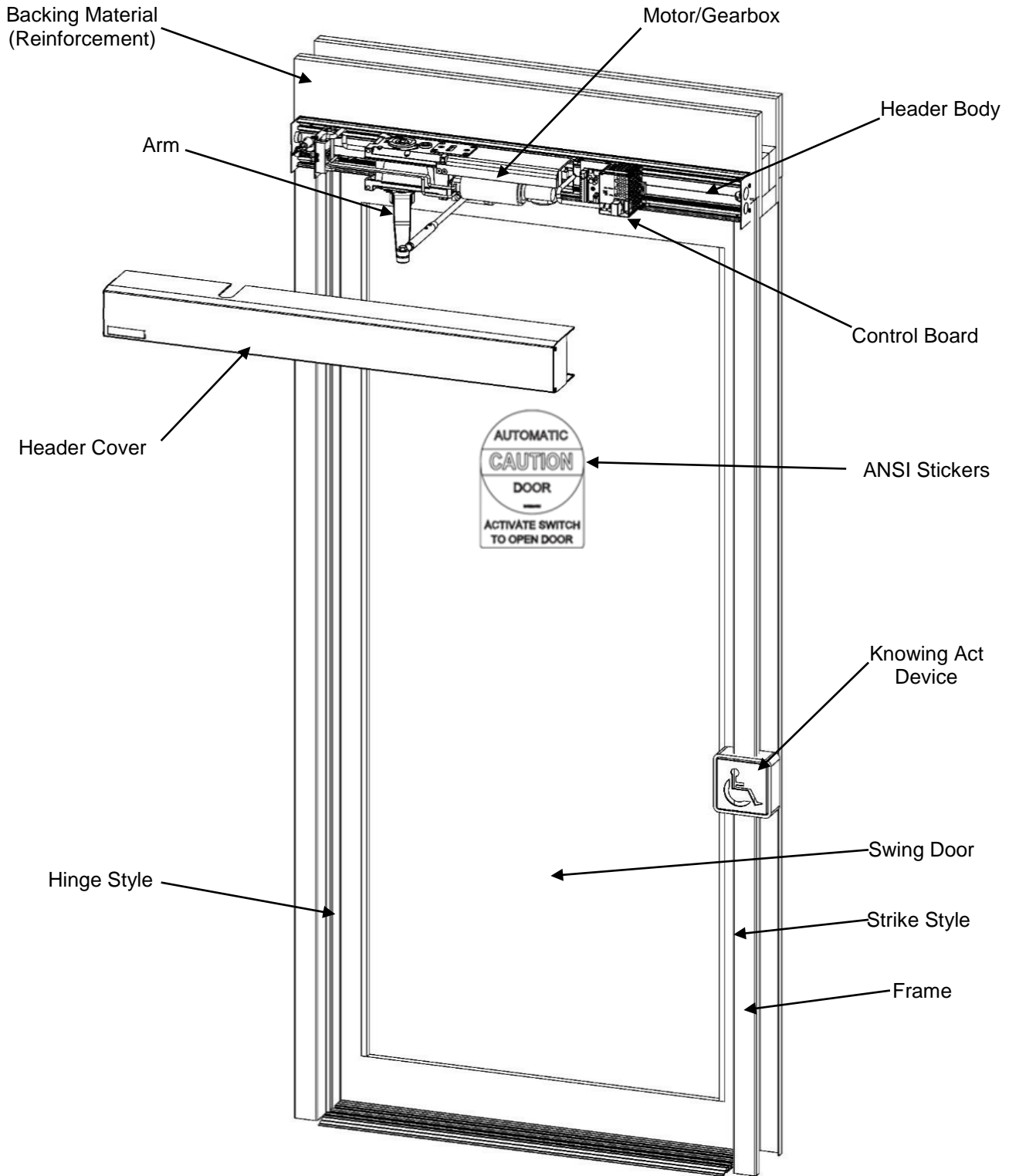

## 1.3 Replacement Parts

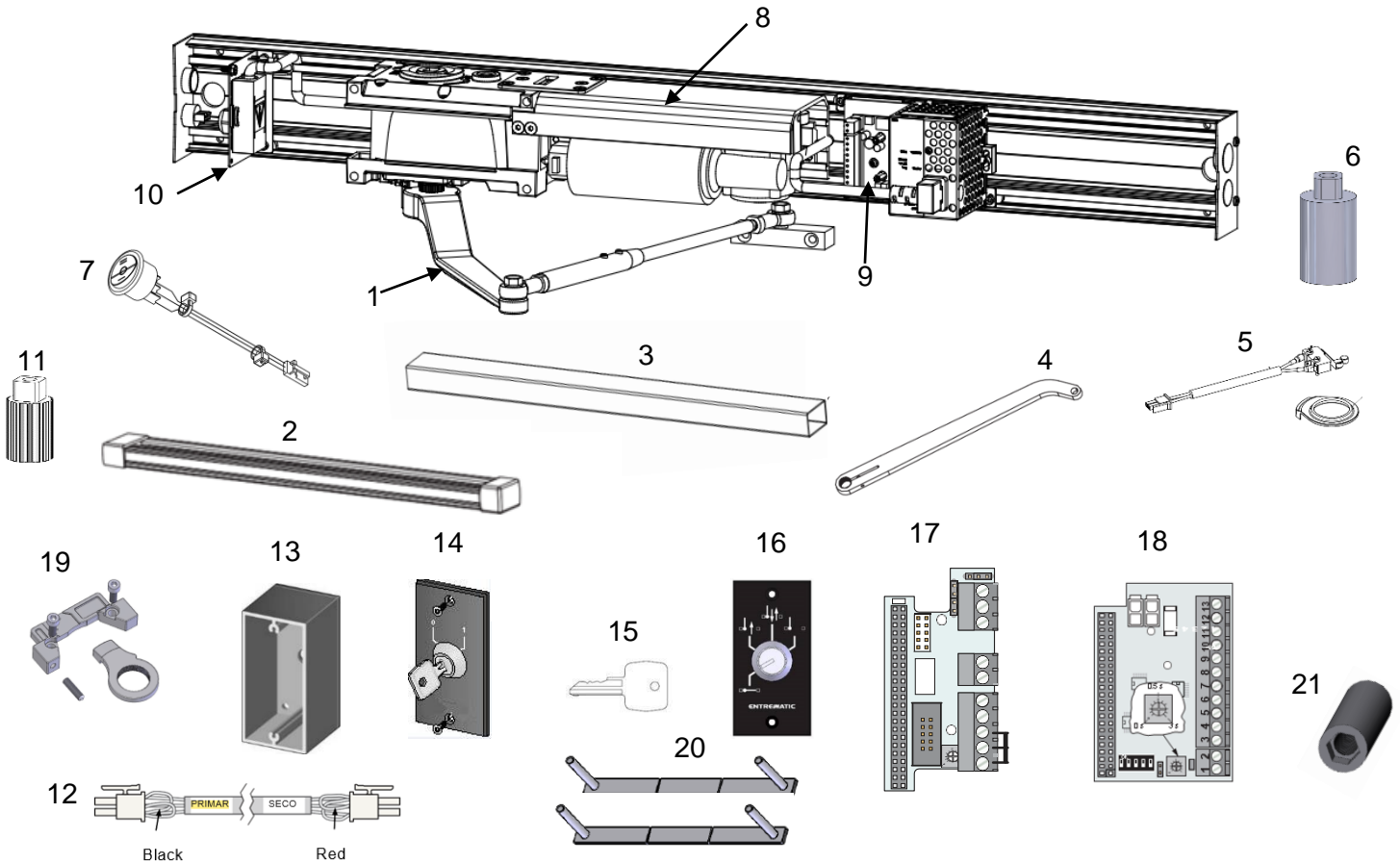

Replacement Parts			
Item	Category	Part No.	Description
1	Push Arm	W7-200	Complete Push Arm-Clear (with 17.5" rod)
		W7-205	Complete Push Arm-Bronze (with 17.5" rod)
		W5-502C	Cast portion - Clear
		W5-502B	Cast portion - Bronze
		W5-500C	Extended Rod 22"- Clear
		W5-500B	Extended Rod 22"- Bronze
2	Pull Arm Track - Long	W5-551	Pull Track Assembly Long - Clear
		W5-556	Pull Track Assembly Long - Bronze
3	1-9/16" x 2-3/8" Reveal Spacer Extrusion	W8-862-BLK	Spacer Assy. - Black
		W8-862-SI	Spacer Assy. - Silver
4	Pull Arm	W5-512C	Pull Arm - Clear
		W5-512B	Pull Arm - Bronze
5	Micro Switch Kit	W8-852	Lock Kick Switch, Cam & Cable (not supplied with unit)

Replacement Parts			
Item	Category	Part No.	Description
6	Spindle Extension	W8-865	Spindle Extension
7	Rocker Switch	W8-804	ON/ OFF/ HOLD OPEN 3 position switch
8	Motor/Gearbox	W8-801	Motor/Gearbox Kit
9	Controls	W8-802	HA9 Controller
10	Conduit	W8-803	Conduit Bracket Kit
11	Shaft Adaptor	W8-805	Shaft Adaptor
12	Sync Cable	W8-850	Sync Cable
13	Program Selector	W8-856	Surface Mount Box
14		W8-857	2 Position PSK-2
15		W8-858	Spare Key PSK/PS-4C
16		W8-859	4 Position w/Key PS-4C
17	Extension Units	W8-860	EXU-SA
18		W8-861	EXU-SI
19	Stop Arm Kit	W8-851	Stop Arm Kit
20	Lock Spacer Kit	W8-853	Lock Spacer Kit
21	Allen Key Head Nut Kit	W8-854	Allen Key Head Nut Kit

## 1.4 Important Information

### Intended Use

The door is designed to offer continuous use, a high degree of safety and maximum lifetime.

The Entrematic HA9 is an automatic swing door operator developed to facilitate entrances to buildings and within buildings through swing doors. The HA9 is a low-energy operator using a DC motor and a gear-reduction system to drive an arm system, which opens the door. **It is to be installed indoors where it is suitable for almost all types** of external and internal swing doors. This widely used operator can be found on applications ranging from handicapped-access in private homes to high-traffic retail operations.

The motor and gear system are combined into a compact unit mounted alongside the control unit within the cover. The operator is connected to the door leaf with different arm systems.

### Safety Precautions

- Do not climb on door parts.
- Do not let children play with the door or the fixed controls.

Be sure to complete a risk assessment according to "Guide for Installers of Powered Pedestrian Swing Doors" (PRA-0006) and fill in the "Site Acceptance Test" (PRA-0007) before taking the door into operation.

To avoid bodily injury, material damage and malfunction of the product, the instructions contained in this manual must be strictly observed during installation, adjustment, repairs etc. Factory authorized training is required to carry out these tasks safely. Only Ditec Entrematic -trained technicians should be allowed to carry out these operations.

### Electronic Equipment Interference

The equipment complies with the European EMC directive (US market FCC Part 15), provided installed according to Installation and Service manual.

The equipment may generate and use radio frequency energy and if not installed and used properly, it may cause interference to radio, television reception or other radio frequency type systems.

If other equipment does not fully comply with immunity requirements interference may occur.

There is no guarantee that interference will not occur in a particular installation. If this equipment does cause interference to radio or television reception, which can be determined by turning the equipment off and on, the user is encouraged to try to correct the interference by one or more of the following measures:

- Re-orient the receiving antenna.
- Relocate the receiver with respect to the equipment.
- Move the receiver away from the equipment.
- Plug the receiver into a different outlet so that equipment and receiver are on different branch circuits.
- Check that protective earth (PE) is connected.

If necessary, the user should consult the dealer or an experienced radio/television technician for additional suggestions.

### Environmental Requirements

Ditec Entrematic products are equipped with electronics and may be equipped with batteries containing materials, which are hazardous to the environment. Disconnect power before removing electronics and make sure it is disposed of properly according to local regulations (how and where) as was done with the packaging material.

### Glazing Materials

The glazing material for swing doors shall comply with ANSI Z97.1.

## 1.5 Compliance Codes and Standards

The operator complies with the following codes and standards:

- UL STD.325 & ANSI/BHMA STD. A156.19; Fire rated UL STD. 10 (b); UL STD. 10(c); NFPA STD. 252
- CAN/CSA STD. C22.2 NO. 247 & CAN/ULC STD. S104

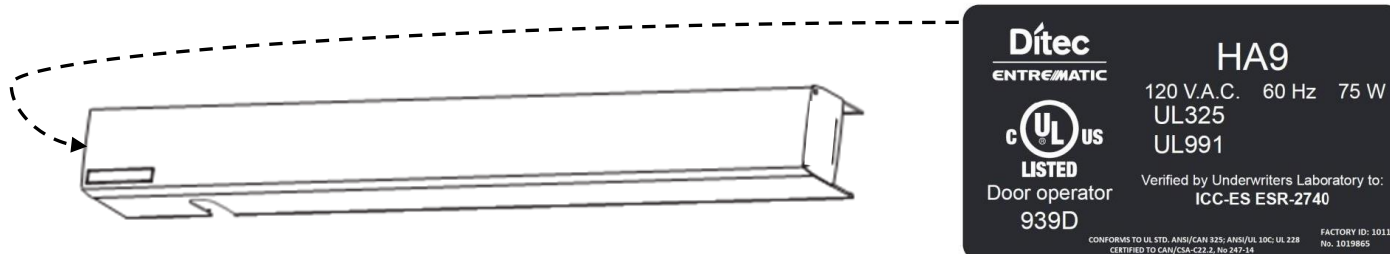

- Under No Circumstances shall the Certification Label of the HA9 operator be tampered, modified Or removed!
- It is the responsibility of the final installer and/or installation company, to certify that the final completed operator is installed in accordance with local building codes and applicable laws.

## 1.6 Technical Specifications

Manufacturer:	<b>Ditec Entrematic</b>
Type:	HA9
Power supply:	120 V AC +10/-15%, 50/60 Hz
Power consumption:	Max. 75 W (AVG. 25 W)
Auxiliary voltage:	24 V DC, max. 400 mA
Internal control fuse:	2 x T 6,3 AH 250 V
Max. weight/width:	Push arm: 200 lbs./48" (94.3kg/1219mm) <b>Note:</b> Refer to the appropriate standard (ANSI A156.10 or ANSI A156.19) for door forces and speeds as related to door weight and width.
Door width:	36-48" (914-1219 mm)
Electro-mechanical locking device:	Selectable: 12V DC, max. 500 mA / 24 V DC, max. 250 mA
Door weight:	100-200 lb. (45-90 kg)
Door opening angle:	Push arm: 80° - 110°, with reveal 0 - 14" (0 - 356 mm) Pull arm: 80° - 110°, with reveal 0 - 2 3/8" (0 - 60mm)
Opening time (0° - 80°):	variable between 3 - 6 seconds
Closing time (90° - 10°):	variable between 3 - 6 seconds
HOLD open time:	1,5-30 seconds
Ambient temperature:	-4 °F to +113 °F (-20 °C to +45 °C)
Degree of protection:	IP20
Degree of protection, control actuators:	IP54
Relative humidity (non-condensing):	Max. 85%
Standards:	The HA9 complies with UL STD.325 & ANSI/BHMA STD. A156.19; Fire rated UL STD. 10 (b); UL STD. 10(c); NFPA STD. 252



## 1.7 How HA9 Works

The low energy swing door operator HA9 uses a motor and a gear-reduction system to drive an arm system, which opens the door. Closing power is provided by a motor and a clock spring. An electronic control unit uses a motor encoder and a microprocessor to control the door's movement.

### Opening

When an opening signal is received by the control unit, the door is opened at the operator-adjusted opening speed. Before the door is fully open at back check, it slows automatically to low speed. The motor stops when the selected door-opening angle has been reached. The open position is held by the motor. If the door is obstructed while opening, it will either stall or stop which can be selected with a DIP switch (SOS).

- When stalling - the door will continue to try to open during the hold open time.
- When stopping - the door will, even if hold open time has not expired, close after 2 seconds.

### Closing

When the hold open time has elapsed, the operator will close the door automatically, using spring force and motor. The door will slow to low speed at latch check before it reaches the fully closed position. The door is kept closed by spring power or extended closing force by the motor.

**Note:** Doorstop is for learning only, not a physical doorstop.

## 1.8 Control Unit HA9 Functions

### Power failure

During power failure, the operator acts as a door closer with controlled closing speed.

### Spring force

The operator is delivered with spring pre-tension factory set to the maximum recommended value of 210°. If necessary, the spring tension can be electronically adjusted with a potentiometer to required closing force. The arm must also be relocated on the spindle.

### Extended closing force/torque (CLTQ)

If the potentiometer CLTQ is set to 0°, the door will close with normal spring power. If the potentiometer is turned clockwise, the motor will increase the closing force/torque.

### Power assist (POAS)

If the potentiometer POAS is set to 0°, the door gives no power assist. If the potentiometer is turned clockwise, the motor will give/increase power assist when the door is opened manually.

### Push and go (PAG)

DIP-switch to select PUSH and GO, ON or OFF. PUSH and GO is available from any door position. PUSH and GO is not Active in program selector setting OFF.

**Note:** Power Assist or Push and Go functions will not work at the same time (one or the other only).

### Sensor & Knowing Act Devices, frame mounted

When a sensor is mounted on the frame or operator cover just above the swing side of the door, it will—when activated—keep the door either open or closed. The sensor is not active during opening and closing. Lockout signal must be connected for proper function.

- A closed door will not open, if the sensor detects activity in the field.
- An open door will not close, if the sensor detects activity in the field.
- During opening, the door will continue to open, even if the sensor detects activity in the field.
- During closing, the door will continue to close, even if the sensor detects activity in the field.
- The sensor is not active in program mode OFF or manually opened door.

### Mat

Mat safety means that:

- A closed door will not open, if someone steps on the mat.
- An open door will not close, if someone steps on the mat.
- During opening, the door will continue to open, even if someone steps on the mat.
- During closing, the door will continue to close, even if someone steps on the mat.
- Opening impulses are prevented during closing, if someone steps on the mat.
- The mat is not active in program mode OFF or manually opened door.

## 1.9 Extension Unit EXU-SI Functions (Standard)

### KILL Function

- If KILL circuit is closed, the control will ignore all signals and close door(s) at normal speed.
- When KILL is no longer active, operator will resume normal operation.
- If KILL function must have manual reset, jumper must be removed and reset button connected to terminal No. 8 and Ground.
- The lock will lock when KILL is active regardless of program selector setting.
- The function of the lock can be changed during KILL Section Changing group of parameters (Level 2)



**In the event that the KILL circuit is activated, all Safety Functions of the door will be overridden causing the door to close even though an object or person may be in the door's path of travel, and therefore may be subject to injury. This mode of operation is most generally used to isolate an area in the event of a fire. KILL can be changed from NO to NC by changing group of parameter level 2.**

### Function of locks

- The lock output only works when the function switch is in OFF or EXIT. If no function switch is used OFF or EXIT must be connected to GND (0 VDC).
- The control has an available output of DC for external locks
- DIP-switches to select 12 or 24 V DC, locked with or without power
- DIP-switch for lock release and potentiometer for opening delay
- DIP-switch for lock kick if door is not fully closed, to overcome binding in the locking device during closing
- Input to unlock signal from lock. Potentiometer for opening delay is to be set to max. As soon as unlock signal is received the door will start to open. The output signal shall be active low.

### Program selector

- Input for OPEN, EXIT and OFF (if no program selector, AUTO is default).

### Activation Signal

- Input for OUTER signal, KEY and OPEN/CLOSE activation signal.

### OPEN/CLOSE Activation Signal

The signal will open the door and the door will stay open until a new signal is given. If no signal is given, the door will close after 15 minutes. This can be made infinite by changing group of parameters Section Changing group of parameters. OPEN/CLOSE signal works only in program selection ON.

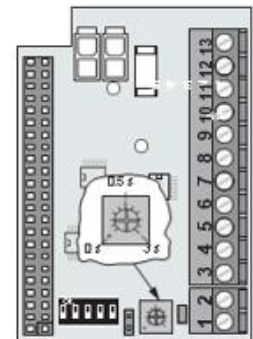

EXU-SI  
(for security functions)  
P/N: W8-861

## 1.10 Extension Unit EXU-SA Functions (Optional)

### Presence signal approach, door mounted

The presence impulse is active during fully open and closing. The sensor is mounted to the approach side of the door. Once the door is closed, the sensor is ignored and will not be active until the next impulse is received.



**When installed as a pair of doors, the presence impulse signal will re-open both doors. The sensor is not active in program mode OFF, manually opened door (Power Failure Mode), Kill Mode.**

### Presence detection swing path, door mounted

When a sensor that is mounted on the swing side of a door detects an object, it will send a command to the control unit to stall the door. If the control unit has received a short signal from the sensor and there is still hold open time left on the control unit, the door will continue on its way open if the object has cleared. The inhibit/blanking potentiometer can be Adjusted so that the sensor will avoid detecting a wall or object near the full open position. Presence detection has a higher priority than presence signal.



**When installed as a pair of doors the presence detection signal will stop both doors, except for double egress doors. The behavior for double egress doors can be changed. The sensor is not active in program mode OFF, manually opened door.**

### Monitored safety sensors

Both presence impulse and presence detection can be monitored. If a sensor becomes defective, the operator will not accept any impulses and will then work as a manual door closer.

### Open door indication

A relay output is used to indicate an opening cycle or a specific position of the door. The indication position is set by adjusting the inhibit/blanking potentiometer.

### Error indication

A potential free contact COM/NO/NC for external error indication.

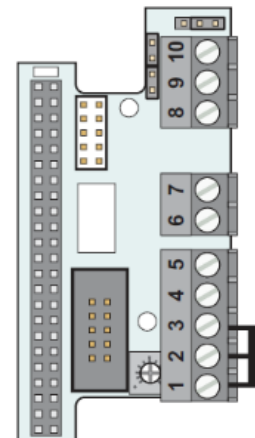

EXU-SA  
(for safety functions)  
P/N: W8-860

## 1.11 Before Installation



- All wiring must conform to standard wiring practice in accordance with national and local wiring codes.
- An incorrectly installed or improperly adjusted door operator can cause property damage or personal injury. These instructions should be followed to avoid the possibility of misapplication or maladjustment.
- All dimensions are given in inches (millimeters), unless otherwise noted.



### Door/Frame Preparation

- Before installation, verify doorframe is properly reinforced and is well anchored in the wall.
- Concealed electrical conduit and concealed switch or sensor wires should be pulled to the frame before proceeding.

### Suggested Fasteners for Frame

- #14 x 2-3/4" (70mm) long sheet metal screws.

### Suggested Fasteners for Door

- #12, #14, Wood screws, Sheet Metal screws, Self-tapping screws of varying lengths depending on applications.



The fastener components listed above are merely suggestions. A technician should use their best discretion to determine what components they will need to complete the job.



**Do Not** use Drywall Screws or Hollow Wall Anchors to mount the backer plate. The header must be strong enough to support 200lbs.

### Shipping inspection

Verify that the order was shipped complete and correct, including model number, door handing, color, and header width.



- If any of the above items are not correct, do not attempt to install until all conditions are correct
- Report any incorrect items to the general contractor immediately.



**NO CLAIMS FOR SHORTAGES WILL BE ALLOWED UNLESS REPORTED WITHIN 24 HOURS OF RECEIPT OF SHIPMENT.**

**Door/ General Tips/ Safety concerns**

- If there are sharp edges after drilling the cable outlets, chamfer the edges to avoid damage to the cables.
- For enhanced security and vandalism protection, always mount the operator access in the interior of a building whenever possible.
- Make sure the ambient temperature is in the range specified in section Technical specification.
- Make sure that the power is off before installing.
- Make sure that the door leaf and the wall are properly reinforced at the installation points.
- Unpack the operator and make sure that all parts are delivered in accordance with the packing note and that the operator is in good mechanical condition.
- Ensure proper material is being used for the door leaves and that there are no sharp edges. Projecting parts shall not create any potential hazards. If glass is used bare glass edges shall not come in contact with other glass. Toughened or laminated glass are suitable glasses.
- Ensure that entrapment between the driven part and the surrounding fixed parts due to the opening movement of the driven part is avoided. The following distances are considered sufficient to avoid entrapments for the parts of the body identified;
  - For fingers, a distance greater than 1" (25mm) or less than 5/16" (8mm).
  - For heads, a distance greater than 8" (200mm).
  - For feet, a distance greater than 2" (50mm).
  - For the whole body, a distance greater than 20" (500mm).
- Danger points shall be safe guarded up to a height of 8' (2.5 m) from the floor level.
- The operator shall not be used with a door set incorporating a wicket door.

## 1.12 Consideration of Surroundings

### Floor Space Requirements for Wheel Chair Maneuvering - Americans with Disabilities Act (ADA)

The owner may request the activation device location; however, the press switch must be in view of the door and not directly on the door or frame. Please refer to ANSI 117.1 Safety Code for further guidelines on switch requirements.



Activation switches shall be at minimum height of 36" (914.4mm) and maximum height of 48" (1219mm) from finished floors or as specified by a local Authority Having Jurisdiction.

Individual who uses wheelchair needs a minimum of 48" clearance to the door swing for doors in sequence application.

**Position# 1**  
Minimum 2' (610mm)  
From door latch

**Position# 2**  
Minimum 5' (3048mm)  
from door face

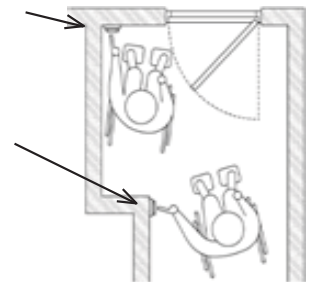

### External and Internal Factors

<b>Door Condition</b>	Door must move easily open and close (latch) without excessive force; weather stripping and Threshold must not interfere with door movement.
<b>Reveal</b>	For out swing (Push) doors, the reveal must be within the range of 0" to 14" (356mm). For in swing (Pull) doors, 0" to 2 3/8" (60mm) for special reveals is allowed - for all others consult factory.
<b>Wind</b>	When installing on a door in a strong wind condition area, special adjustments should be made to the doorstop position and controller adjustments.
<b>Power/Control Wires</b>	Check that the electrical feed, all conduits, and electrical junction boxes (for push plates or other activation devices, if required) are correctly located in accordance with final approved shop drawings and within the guidelines of the enforced local electrical codes.

### Required Tools for Installation:

- Torx, T10
- Allen Wrench Set
- Power Drill and Drill Bits
- Level
- Center Punch
- Tape Measure
- Wire Stripper
- Nut Driver, 5mm
- Screwdrivers: Flat, Philip, 5/16" Hex. Nut
- Additional Fasteners Depending Surface
- Shims
- Silicone Sealant
- Hand Saw/ Power Saw

## 1.13 Operator Type and Handing

The system is either a Push or Pull type configured for left or right door handing. Door handing is determined by standing with your back to the hinges. The side to which the door normally opens (right or left) is the handing of the door. The diagram below shows a right-handed door.

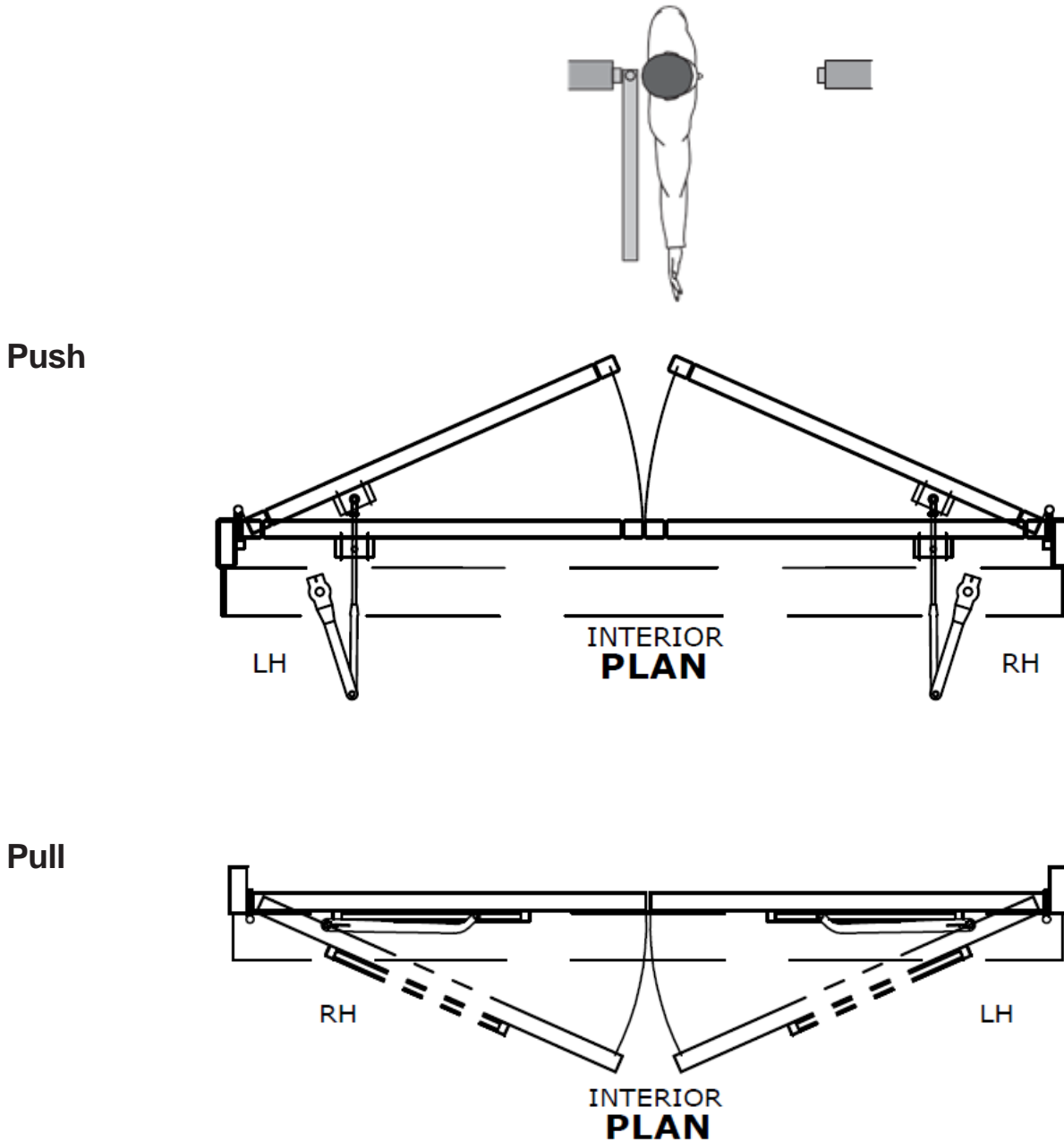



## 2.1 Pre-Mounting Header Box Instructions

### Disassemble parts for installation

Remove the cover from the assembly by gently prying with a screwdriver. Once the snaps are clear, pull the cover outwards with minimal effort. Carefully set the cover in a location where it will not be damaged.

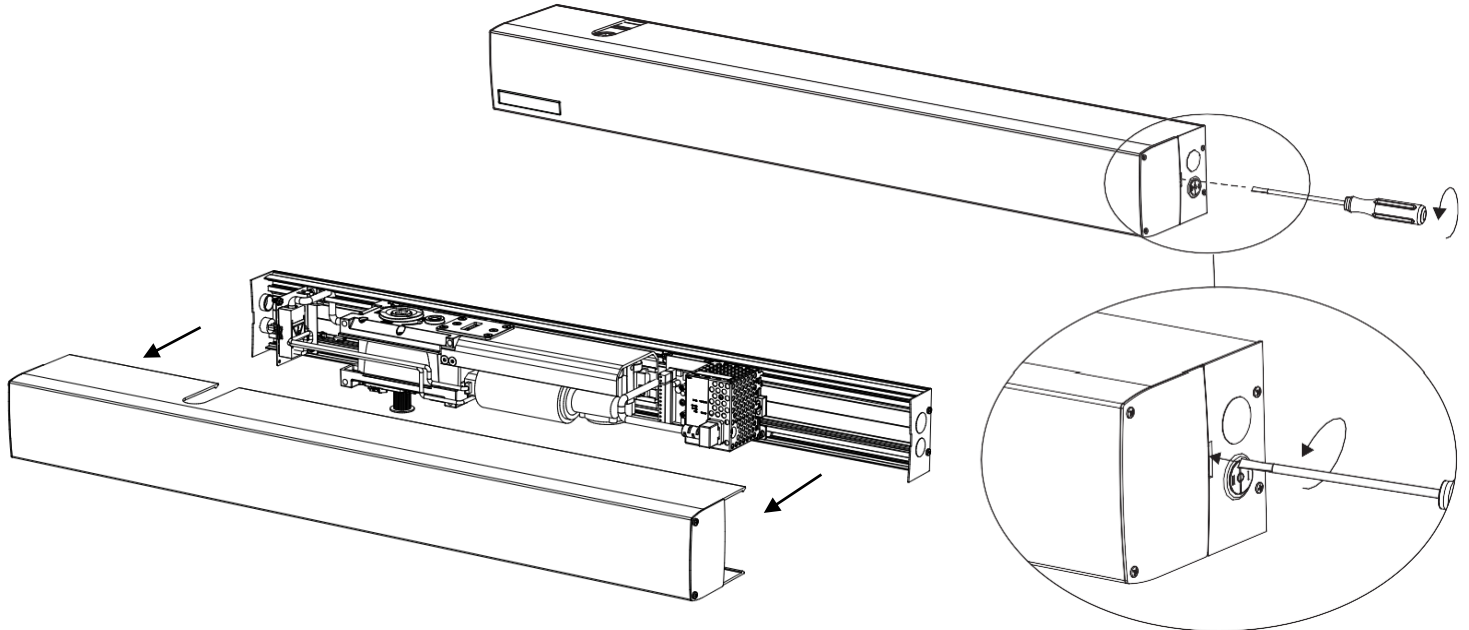

Mark spindle center on the bottom edge of header and remove the motor/gearbox from the back plate by loosening 4 motor/gearbox nuts.



**The spindle center must be marked prior to removing the motor/gearbox to locate back plate to door frame and reinstallation.**

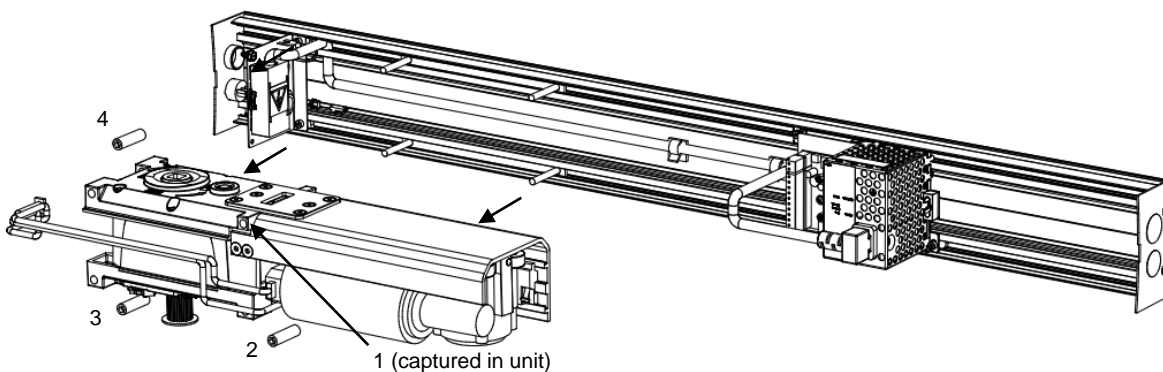

## 2.2 Push Header Installation

The Header Box on push installations is mounted flush to the bottom of the door frame. It may require solid backing material to compensate for the thickness of the door frame.



Holes can be made anywhere in header to secure. All holes **MUST** be drilled into substantial support (studs, blocks, framing, etc.). This diagram may not reflect your installation.



**Do Not** use Drywall Screws or Hollow Wall Anchors to mount the back plate / header.

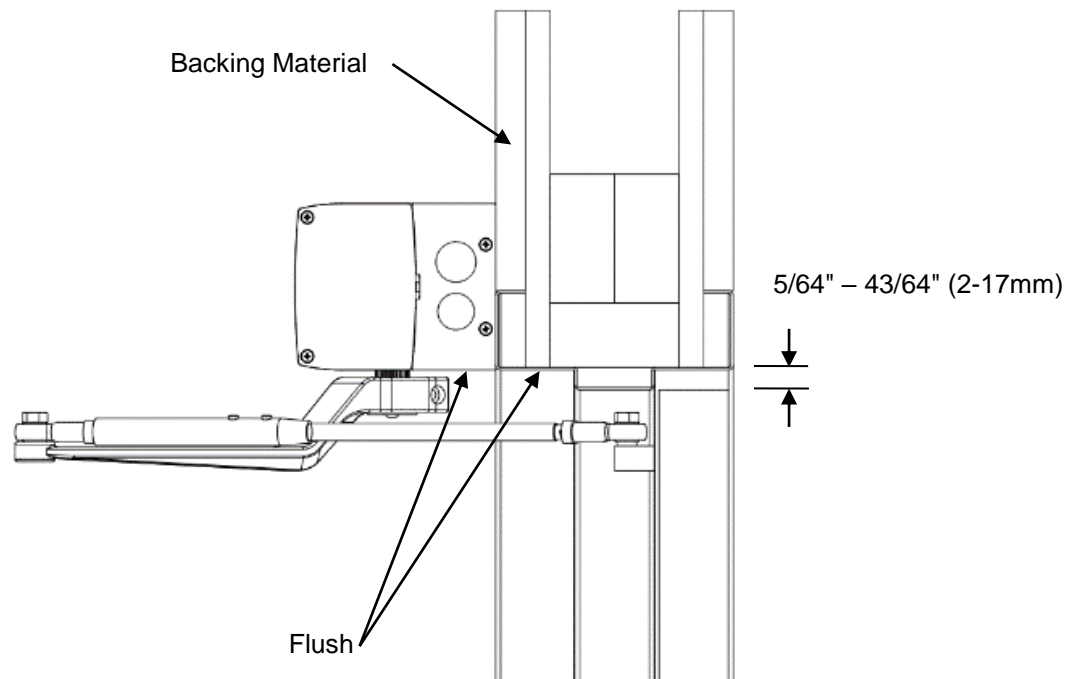

Before fastening header box to the door frame, dry fit header by positioning the backer plate flush to the bottom of the door jamb and the previously marked spindle center line is  $8\frac{1}{4}$ " (210mm) from the door hinge/pivot.

1. Mark locations to drill frame to match the predrilled access holes for high and low voltage wires and mounting holes. If the holes are not at a convenient location, you can drill the backer plate to suit.
2. Anchor the back plate to the wall with minimum of six (6) - #14 x 1" Pan Quad Type A screws (provided). You may need to provide other screws if your installation requires it. The locations of the screws on the header are application dependent but (2) of the screws must fasten the back plate directly to the door's vertical jambs on the hinge or pivot side.
3. Add additional screws to fasten the header back plate to the door frame approximately 12" to 16" (305mm to 406mm) apart. **The header must be strong enough to support 200 lbs. (90kg).**



For most applications, the header is equal to door opening plus 3" (76mm). This allows for a  $1\frac{1}{2}$ " (38mm) space on either side of the Header Box. However, it **MUST** be installed  $1\frac{1}{2}$ " (38mm) from hinge side for all Push installations, regardless if header is sized appropriately to anchor the header box properly to the frame.

**Push Header Backer Plate Positioning**

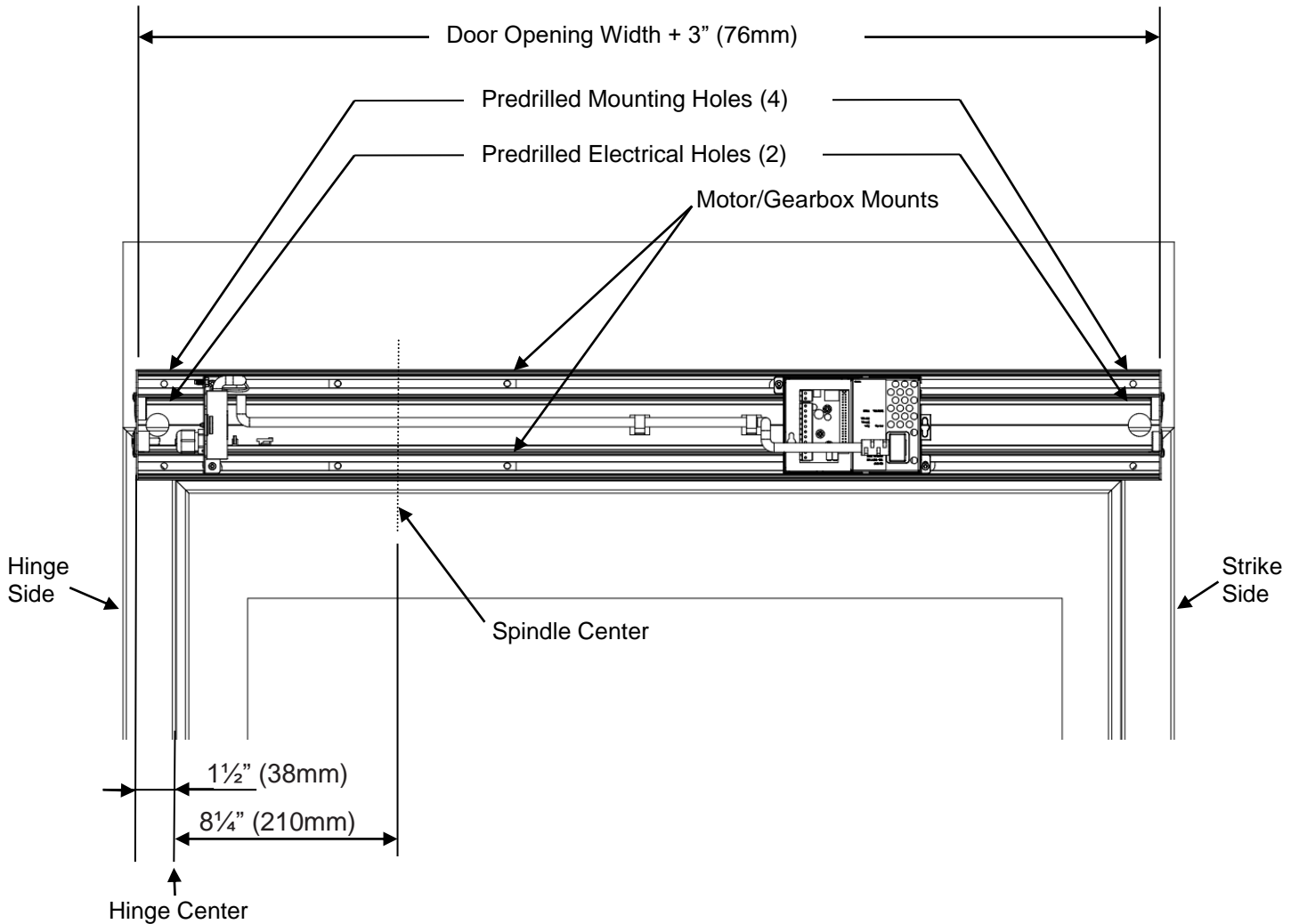

4. Complete high voltage and control board connections (see section 2.5).
5. Reinstall motor/gearbox (see section 2.6).
6. Install arm (see section 3.1).

## 2.3 Pull Header Installation

The Header Box on pull installations is mounted  $1 \frac{1}{8}$ " (28.57mm) above the bottom of the door frame. It may require solid backing material to compensate for the thickness of the door frame.



Holes can be made anywhere in header to secure. All holes **MUST** be drilled into substantial support (studs, blocks, framing, etc.). This diagram may not reflect your installation.



**Do Not** use Drywall Screws or Hollow Wall Anchors to mount the back plate / header.

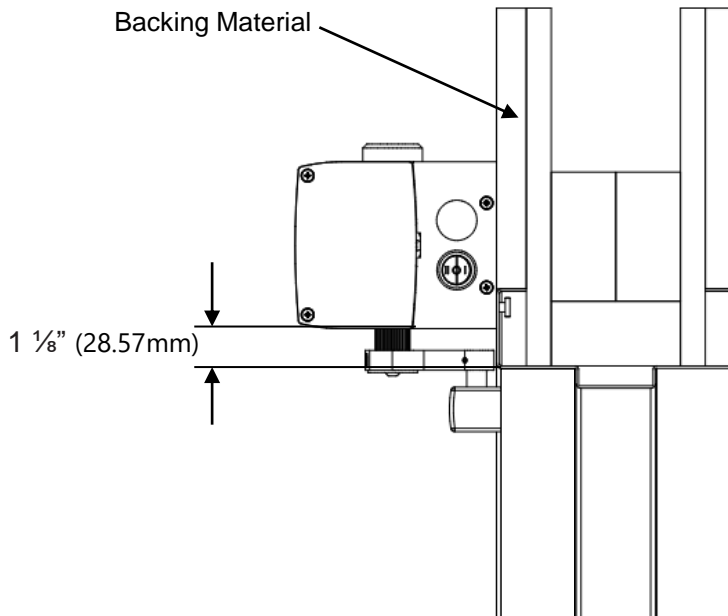

1. Before fastening header box to the door frame, dry fit header by positioning the backer plate flush to the bottom of the door jamb and the previously marked spindle center line is  $8 \frac{1}{4}$ " (210mm) from the door hinge/pivot.
2. Mark locations to drill frame to match the predrilled access holes for high and low voltage wires and mounting holes. If the holes are not at a convenient location, you can drill the backer plate to suit.
3. Anchor the back plate to the wall with minimum of six (6) - #14 x 1" Pan Quad Type A screws (provided). You may need to provide other screws if your installation requires it. The locations of the screws on the header are application dependent but (2) of the screws must fasten the back plate directly to the door's vertical jambs on the hinge side.
4. Add additional screws to fasten the header back plate to the door frame approximately 12" to 16" (305mm to 406mm) apart. **The header must be strong enough to support 200 lbs. (90kg).**



For most applications, the header is equal to door opening plus 3" (76mm). This allows for a  $1 \frac{1}{2}$ " (38mm) space on either side of the Header Box. However, it **MUST** be installed  $1 \frac{1}{2}$ " (38mm) from hinge side for all Push installations, regardless if header is sized appropriately to anchor the header box properly to the frame.

**Pull Header Backer Plate Positioning**

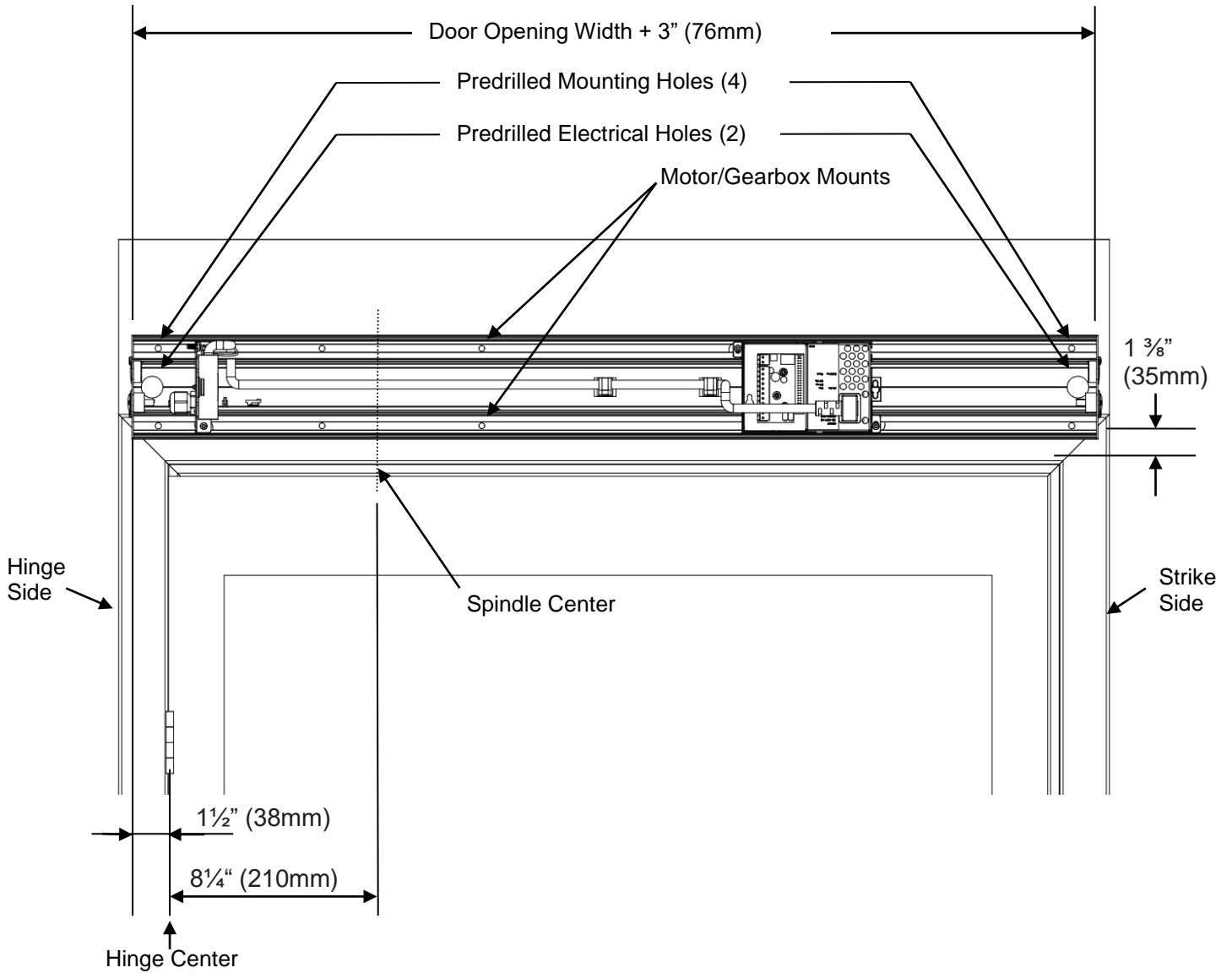

5. Complete high voltage and control board connections (see section 2.5).
6. Change configuration from push to pull (see section 2.6).
7. Reinstall motor/gearbox (see section 2.7).
8. Install arm (see section 3.1).

## 2.4 Double Egress Header

Double Egress Operators have a PULL type and PUSH type operator in the same housing, the header must be mounted using the same process as the single Pull type locating  $1 \frac{1}{8}$ " (29mm) above the door frame and the spindle center  $8 \frac{1}{4}$ " (210mm) from the door hinge/pivot. For PUSH type operator, arm clearance issues may arise. To ensure the arm clears any existing doorstops, use Option 2 Alternate Configuration to mount the arm as shown in the diagram below.

**Note:** For this configuration the spindle extension W8-865 is available and comes with  $5 \frac{1}{4}$ " (133.35mm) long bolt.

See Section 3.1 to change the Push arm configuration to Option 2.

**Horizontal Section**

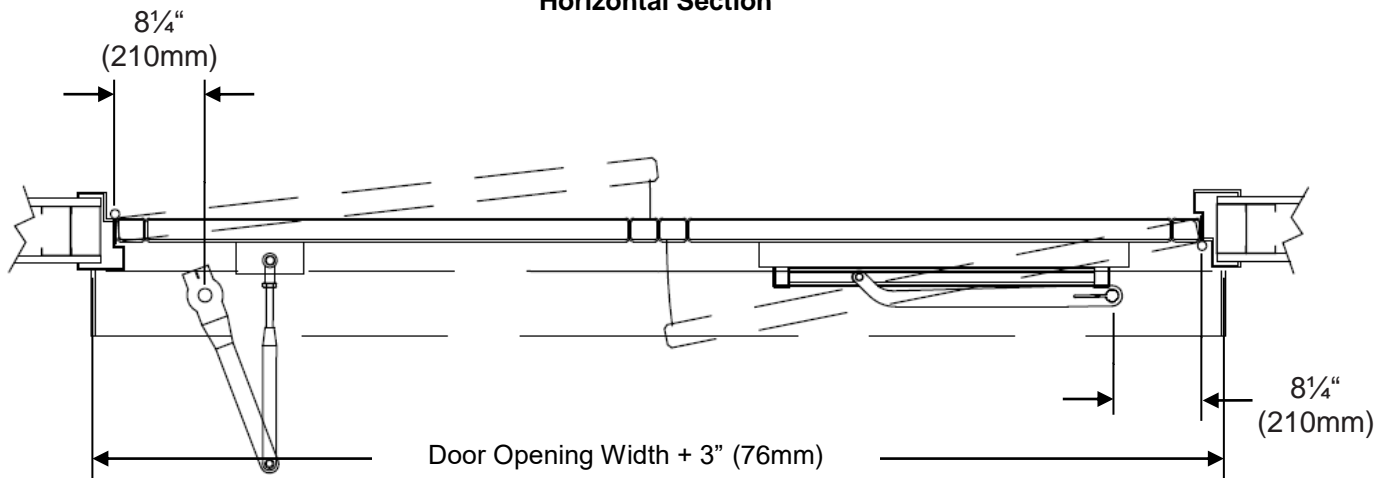

**Vertical Section**

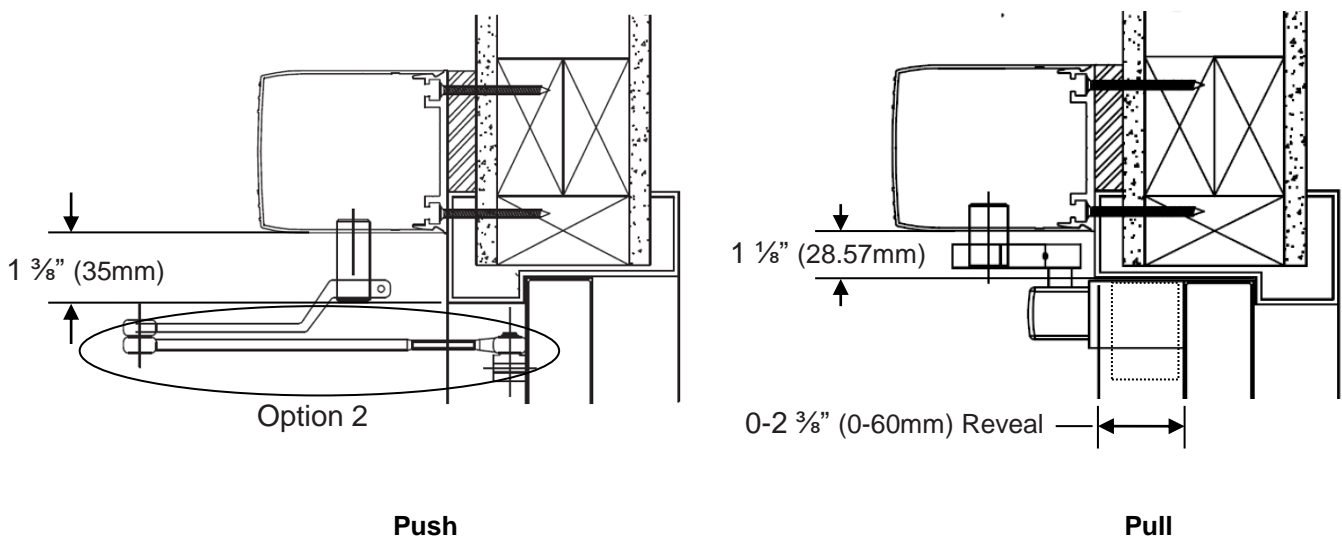

## 2.5 Electrical Connection

The incoming mains, which is a single phase 50/60 Hz AC voltage between 100 V -10% and 240 V+10% fuse 10 AT, is connected in the mains connection unit.

1. Remove the protective lid (2).
2. Connect the incoming mains power (4) through the strain relief (3) to the connection block (1) as shown in the illustration below.
3. Put the protective lid (2) back in place.



**Installer must properly ground door package! Improper grounding can lead to risk of personal injury.**

- 1 Mains connection block
- 2 Protective lid
- 3 Strain relief
- 4 Incoming mains power
- 5 Mains connection
- 6 HA9 control board

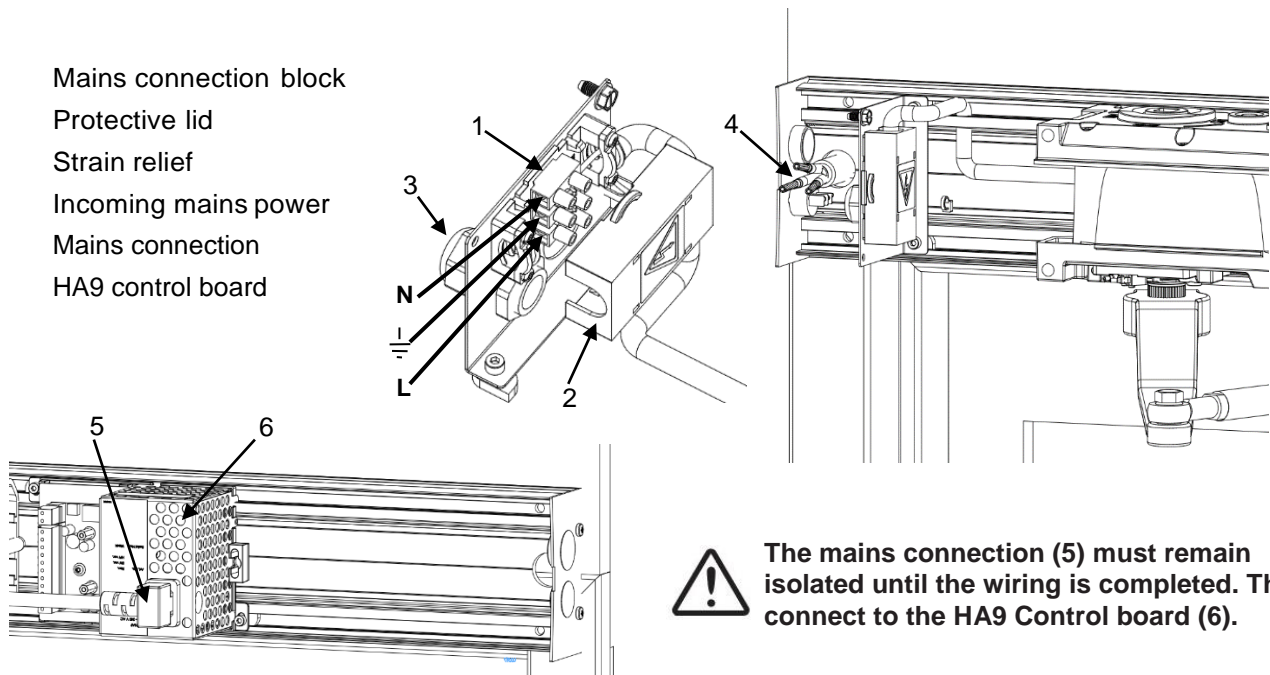

The control board settings have been pre-set prior to shipment. It will be necessary for the door operator to be functional while adjustments and settings are made. Power up the unit, push an activating device and check to make sure that the spline pinion drive rotates in the correct direction. Keep all wires away from moving parts and sharp edges that may cut into the outer casing of the wires.

**THE GROUND WIRE FOR THE INCOMING HIGH VOLTAGE POWER AND THE SYSTEM GROUND WIRE CANNOT SHARE THE SAME GROUNDING STUD. GROUND THE INCOMING HIGH VOLTAGE ACCORDINGLY.**

- Installation of any extra wiring for controls or accessories into the header unit shall be secured and away From any moving parts.
- If the motor is not plugged into the circuit board, there is no resistance against the spring when manually opening the door. The door or arm will close very quickly if opened.
- If an electrical access hole is added or knocked-out of the end plates, code approved electrical transfers must be used. Hole cannot be knocked out and unfilled.

## 2.6 Change Unit Configuration

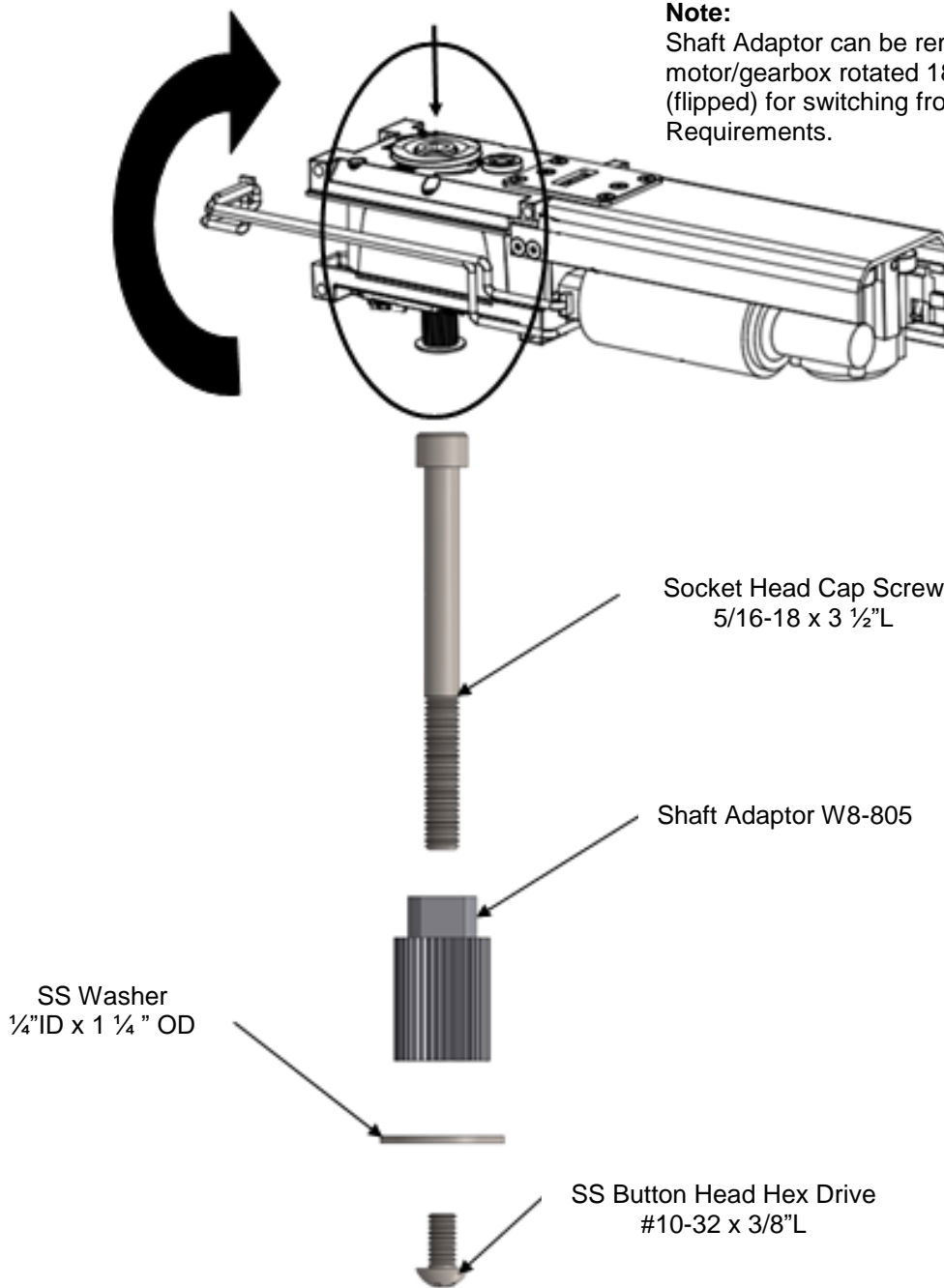

**Note:**  
Shaft Adaptor can be removed and the motor/gearbox rotated 180 degrees (flipped) for switching from Push to Pull Requirements.



Place arm on unit at center line of unit. Then rotate the arm  $-5^\circ$  (while holding the unit) so you can remove the two screws that hold the Lock Kick / Stop Block Assembly. The Arm is under spring load so do not release. After removing Lock Kick / Stop Block Assembly allow the arm to gently rotate to remove the spring load.

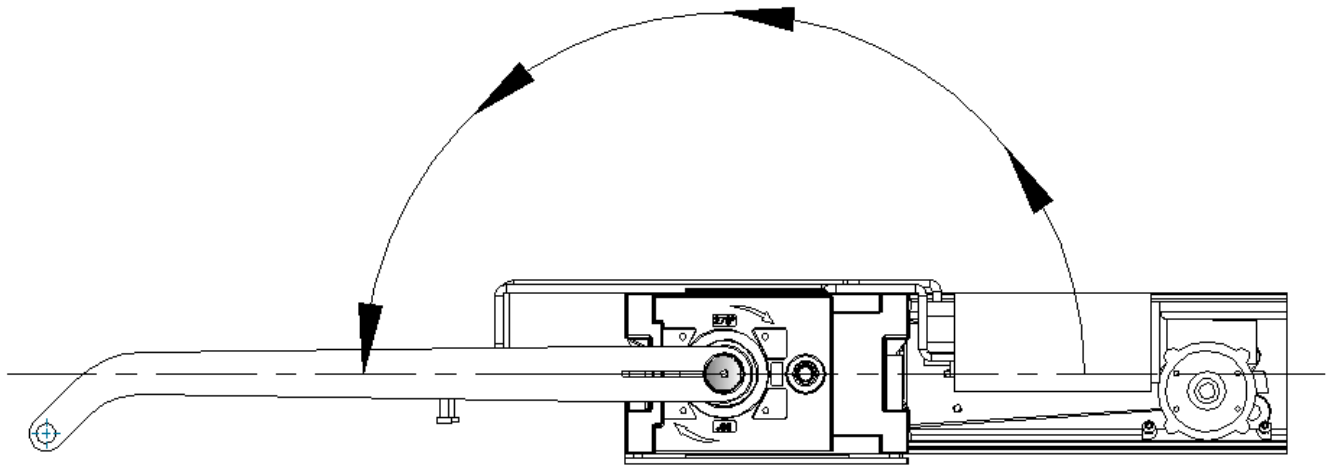
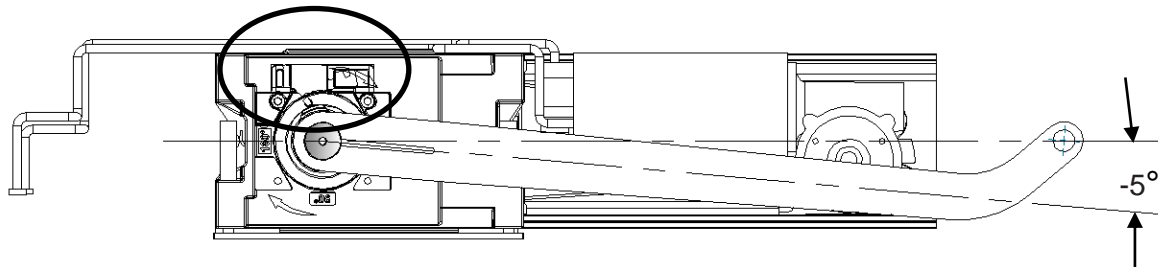

Reinstall the Lock Kick / Stop Block Assembly in the alternate location ( $180^\circ$  from its original position).

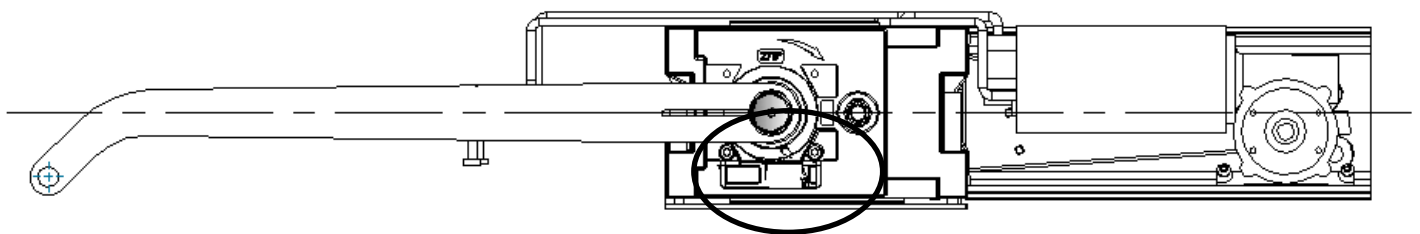

Rotate arm 180° (while holding the unit) so you can reload the spring tension and reposition stop arm.

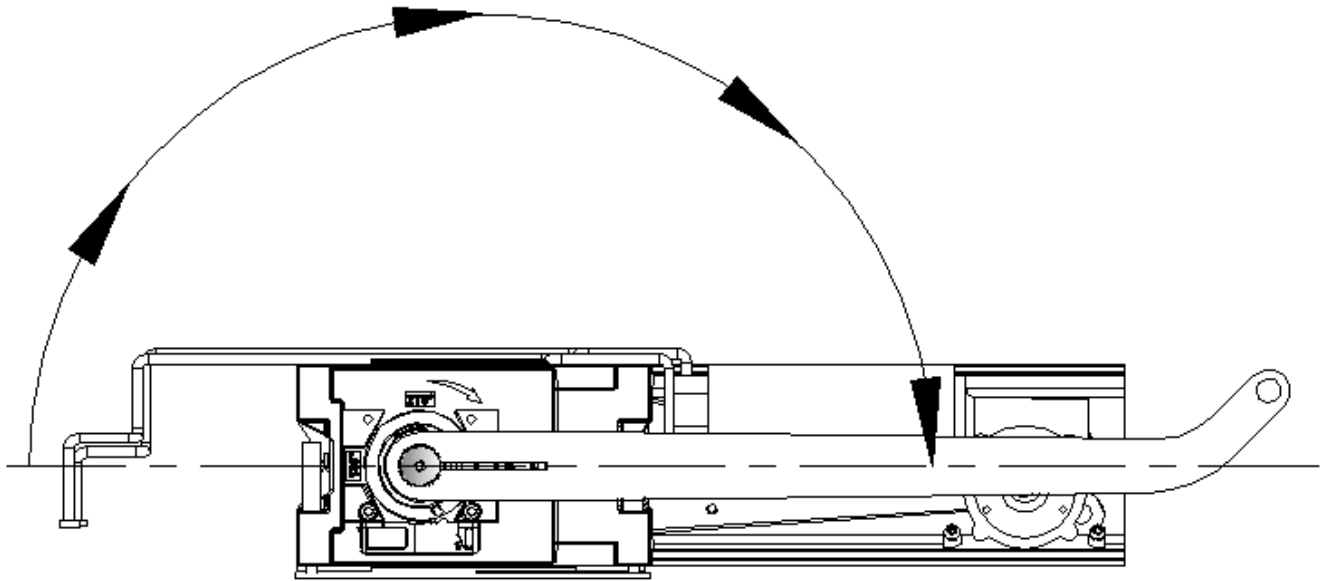

While holding the arm in position, gently lift the lock kick cam and the door stop arm, rotate the door stop arm so it is against the stop block and press it down so it locks into the splines. When you release your grip on the arm the stop block should keep it from rotating. Now position the lock kick cam so it locks into the splines.

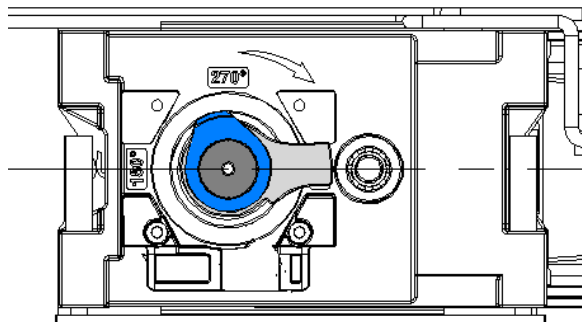
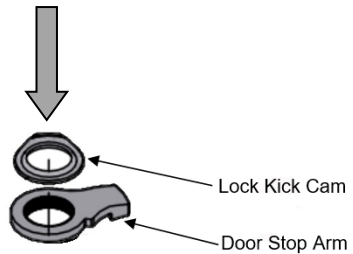
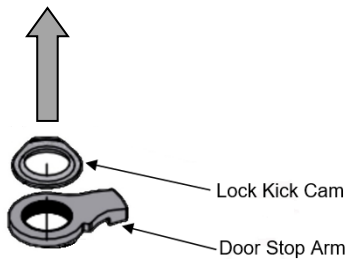

Arm not shown for clarity.

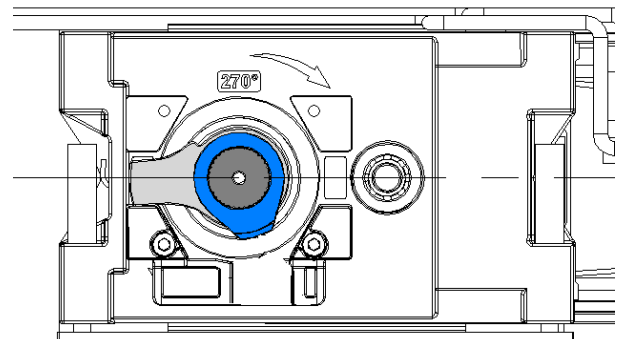

## 2.7 Motor/Gearbox Reinstallation

1. Place motor/gearbox back on mounting studs. Verify power wire length allows for flat, unbound and not stretched when reinstalling motor/gearbox (as shown in diagram below).

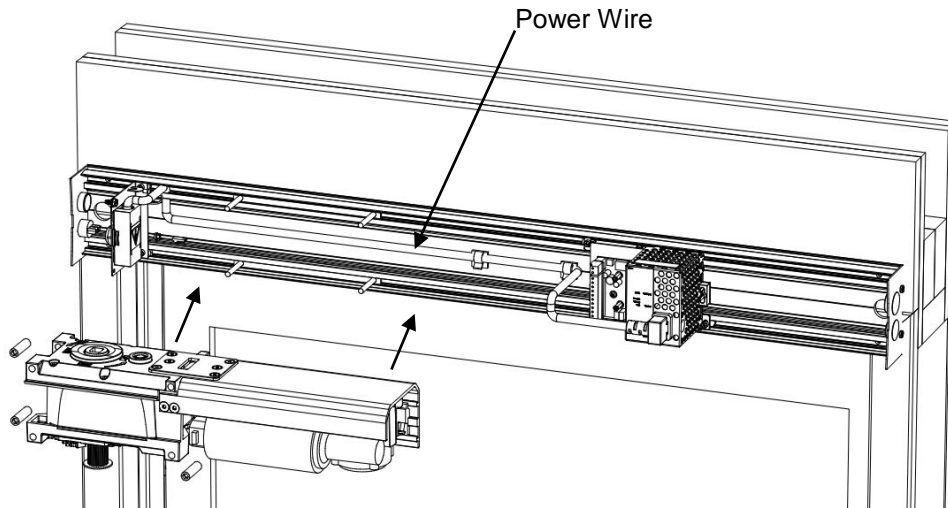

2. Position motor/gearbox so that the spindle is in line with the previously marked spindle center location. Tighten motor/gearbox nuts starting with the top center nut first then the rest in a clockwise pattern.



Verify that the spindle center is 8¼" (210mm) from the door hinge/pivot.

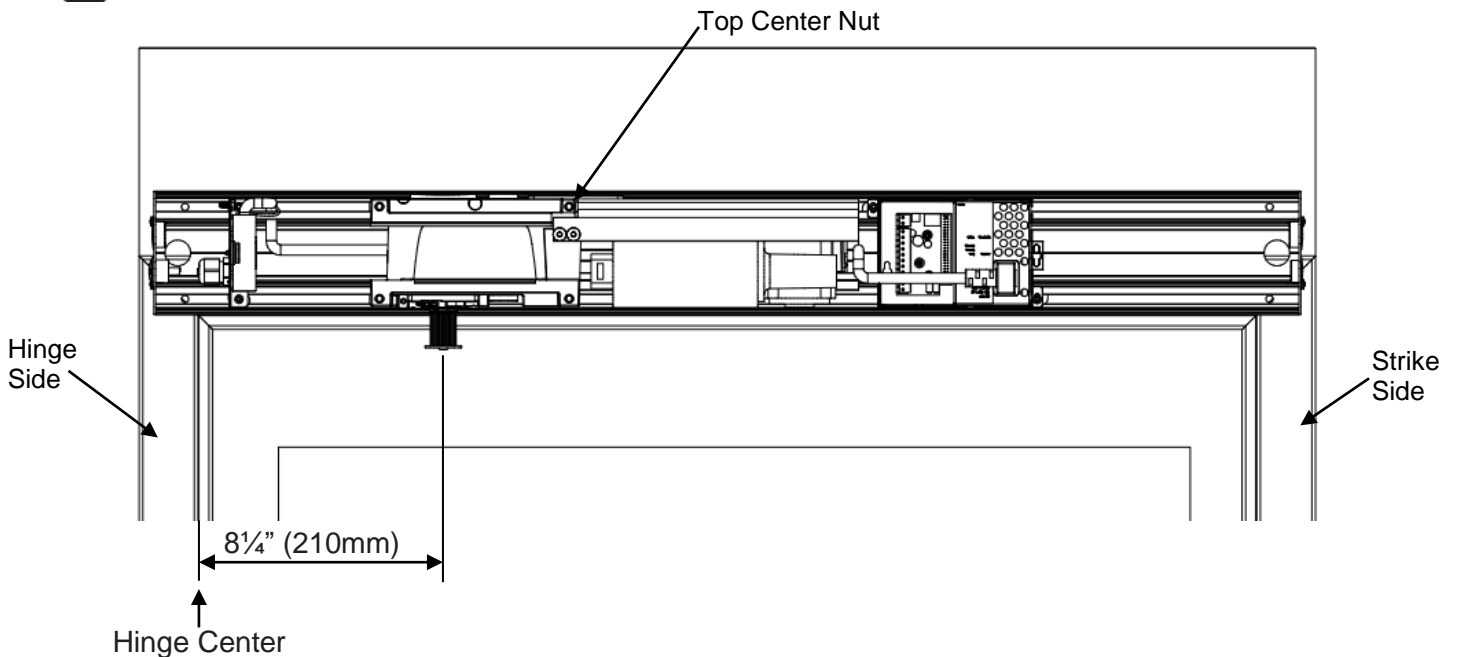

3. Reconnect motor/gearbox control wires.

## 3.1 Push Arm Components & Configurations

The main arm components will consist of the **Main Handle**, **Sleeve**, **Adjustable Rod** (cut to length), and **Door Shoe**, As shown below.

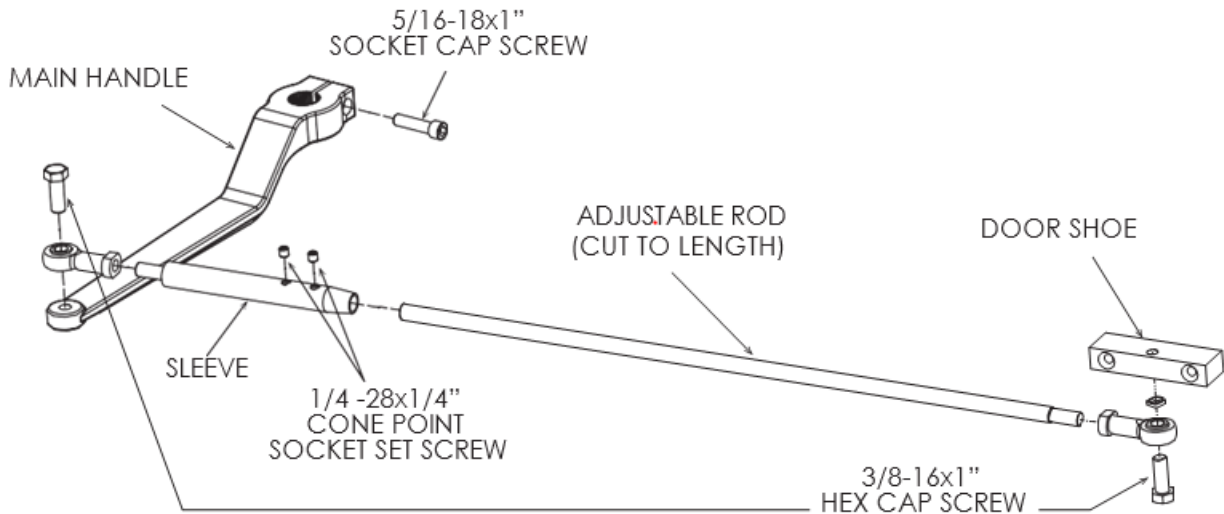

There are two (2) configurations available depends on situation and/or applications

### Option 1- Standard Configuration

This is the standard configuration for the push arm, the Sleeve and Rod are above the Main Handle. Use this configuration when there is no issue with clearance between the Rod/Door Shoe and top jamb of the door frame. The Rod and Sleeve are flexible at the ends where they are bolted (semi-ball joint) which will provide additional flexibility during install.

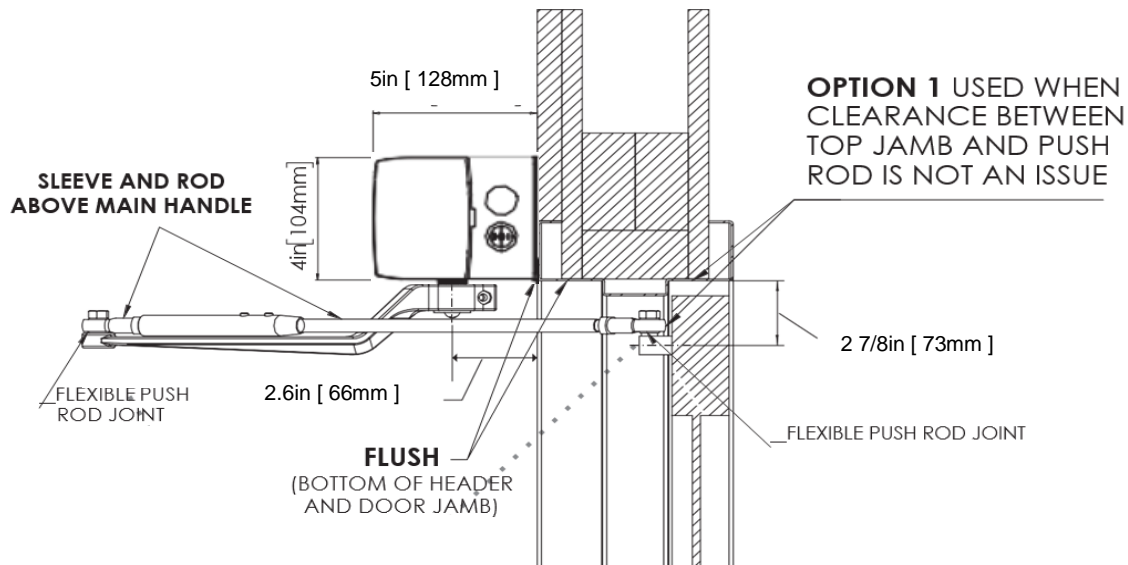

### WARNING!

Please ensure Shoe Bolts at these joints are tightened after installation of arm is complete.

## Option 2 - Alternate Configuration

For this option, Sleeve and Rod are below the Main Handle. Use this configuration when the clearance between the Rod/Door Shoe and the top jamb (or any other obstruction in the swing path) prevents **Option 1** from being properly installed. With this option, an approximate 1 inch in vertical space is gained. This configuration also uses on Double Egress Headers, where there is a pull arm and a push arm installed. The Rod and Sleeve are flexible at the ends where they are bolted (semi-ball joint) which will provide additional flexibility during install.



**Note that the Rod is above the door shoe when installed, so that if the bolt ever loosens it will not fall down via gravity. Should the door rail you are attaching to have a thinner horizontal top rail, the door shoe can be reversed to be above the rod end if space permits.**

Used when clearance is an issue, an extra inch or more is added for installation.

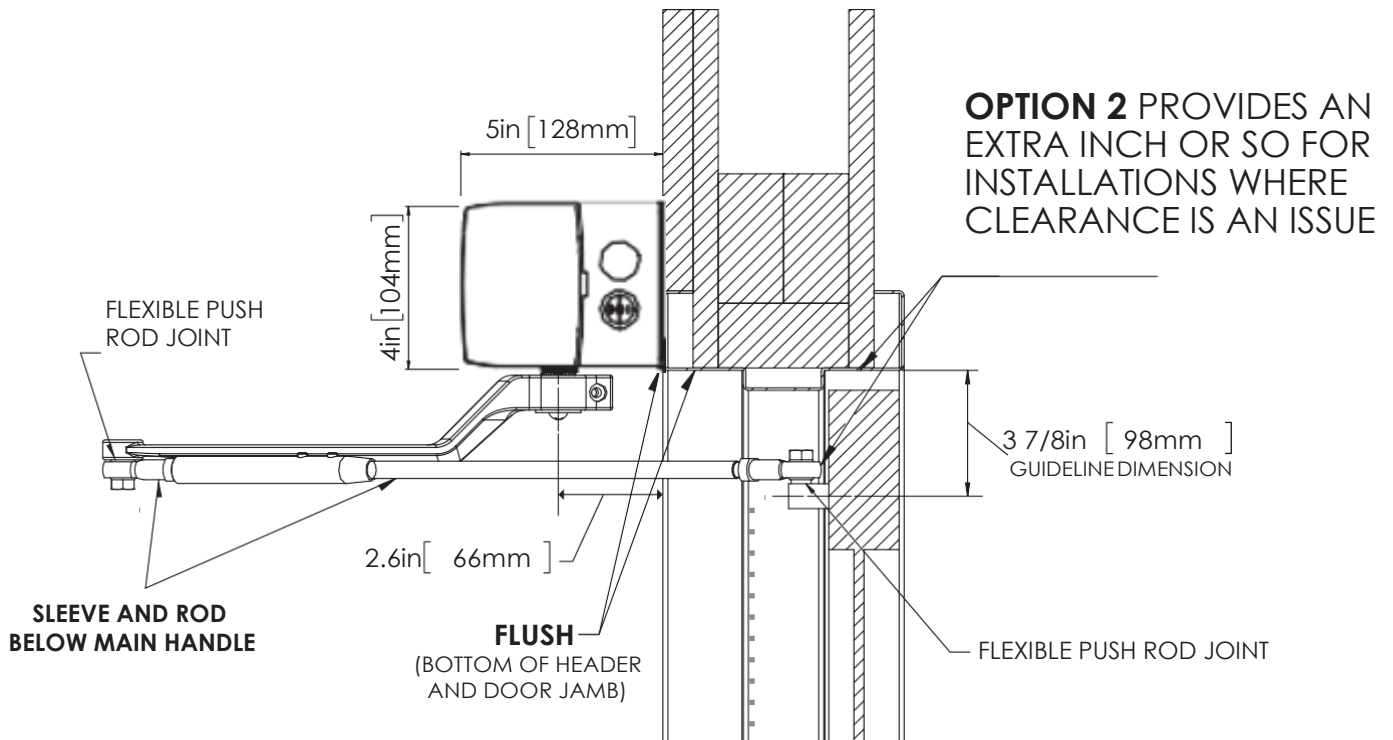

### WARNING!

Please ensure Shoe Bolts at these joints are tightened after installation of arm is complete.

## 3.2 Push Arm Installation

### STEP 1

Keep the door in close position,

Install Door Shoe  $9 \frac{3}{8}"$  (238mm) to first hole from hinge/pivot side, the second hole  $2 \frac{1}{2}"$  (64mm) from the first. For push arm configuration option 1 both the holes are located at  $2 \frac{7}{8}"$  (73mm) from the bottom of header and  $3 \frac{7}{8}"$  (98mm) for option 2.

Open door manually and insert rod fully into sleeve. Tighten set screw. Fit Main Handle and Sleeve on drive shaft (spindle) at 80 degrees to the door latch.

### STEP 2

Line up Rod with Sleeve and mark  $1"$  (25mm) past 2nd set screw and cut

**Remove Main Handle from drive shaft (spindle),** and insert Rod fully into Sleeve. Tighten set screws.

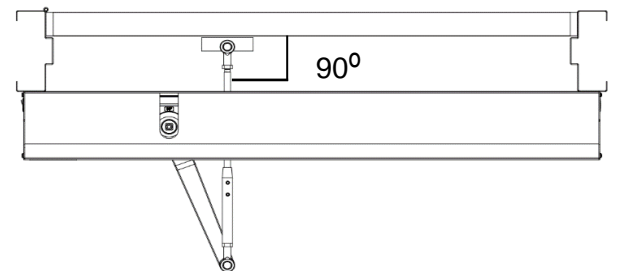
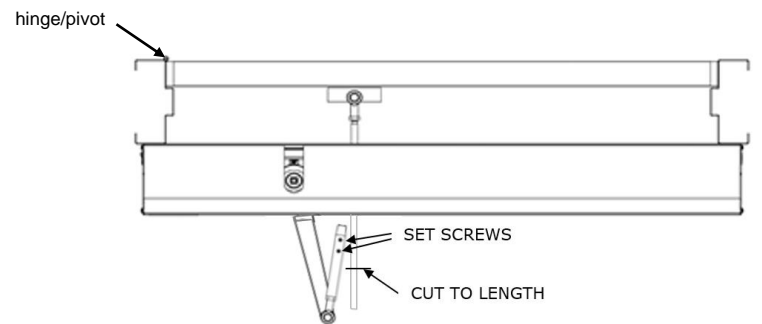
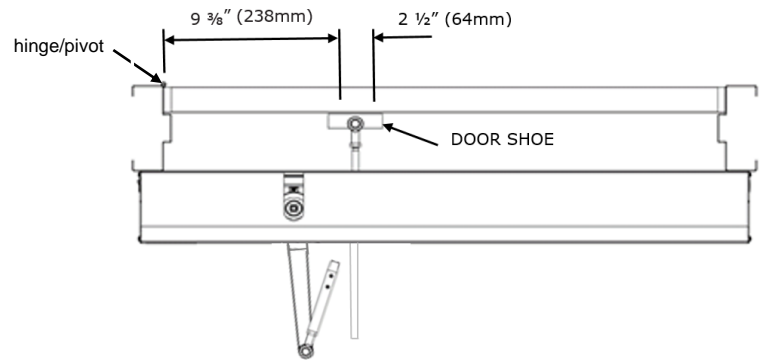

### WARNING!

Please ensure Shoe Bolts at these joints are tightened after installation of arm is complete.

**3.3 Pull Arm for Pull Application**

Pull Arm is used as Pull arm, allowing flexibility to mount the HA9 in either handing configuration.

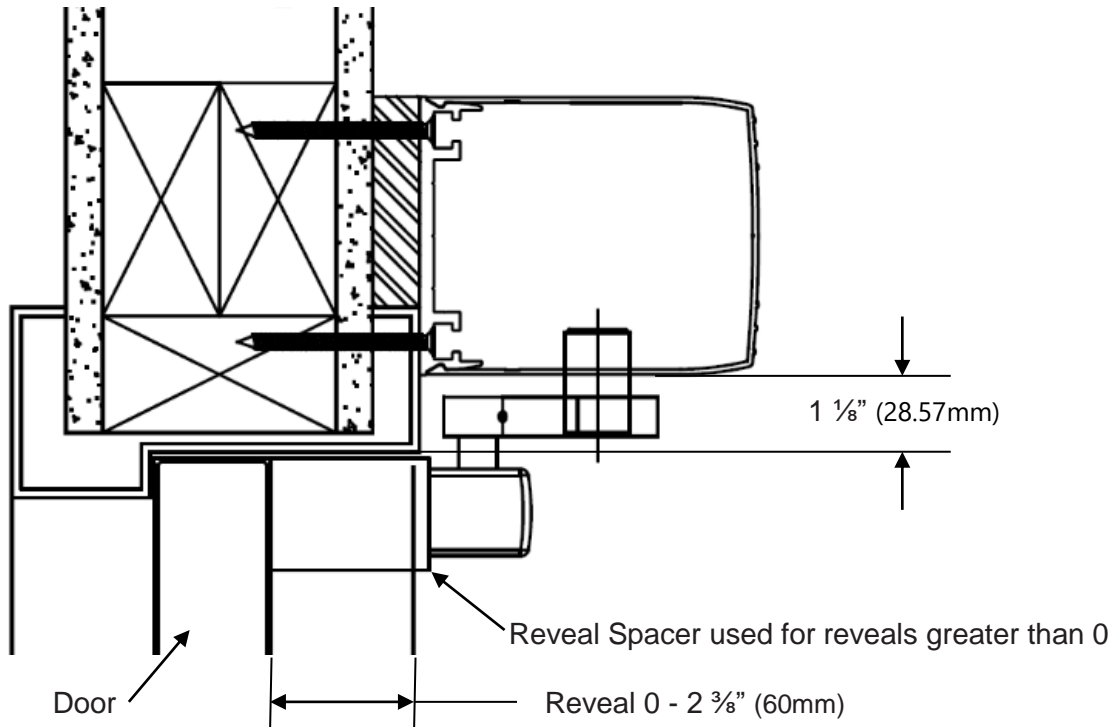
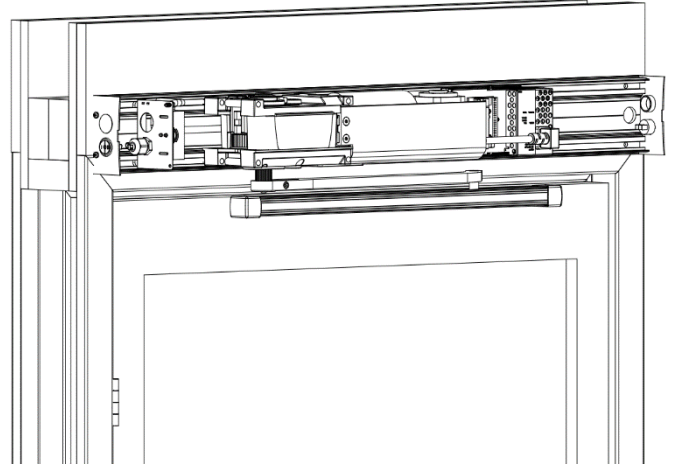
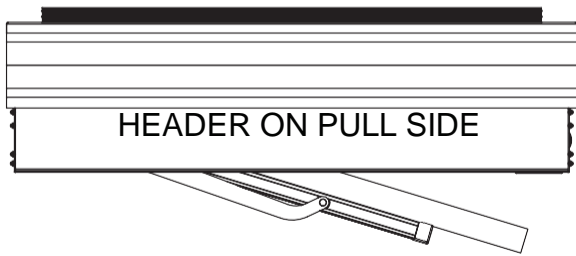

## STEP 1 - Mark minimum position

- Close the door fully and fit the pull arm to the drive shaft (spindle), so that the arm is parallel with the door and the roller is contacting the door.
- In this closed position, mark the spot at the roller edge (directly beside the roller on the strike side of the door).

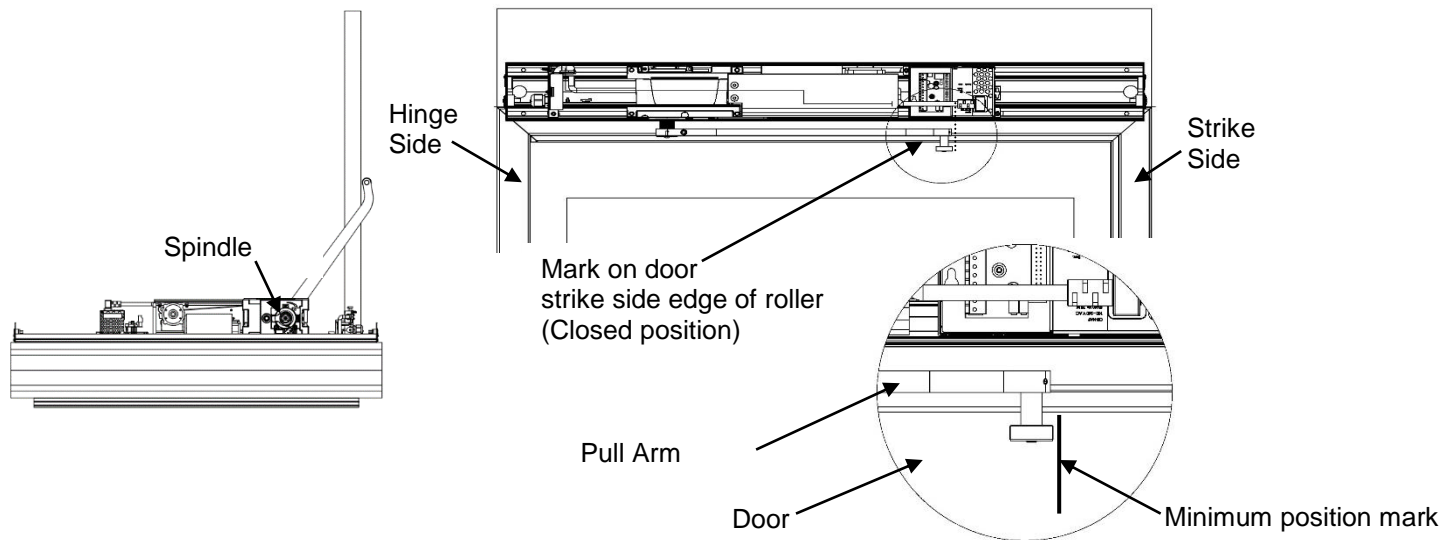

## STEP 2 - Mark maximum position

- Fit the pull arm to the drive shaft (spindle) at full open position (switch to Hold Open (II)), but do not tighten the #1/4"-20 x 7/8" socket cap screw all the way. This is to allow the arm some freedom/flexibility. The pull arm must be positioned such that it is just in front of the door as shown.
- Mark the spot at the roller edge (directly beside the roller on the hinge side of the door) in the open position.

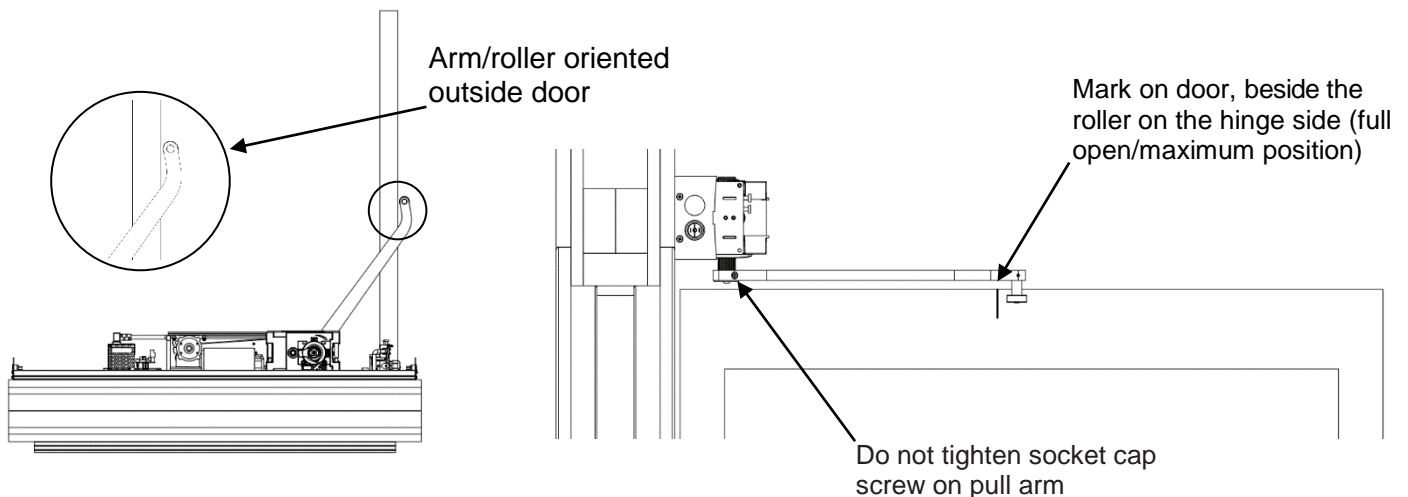



## STEP 3 - Determine pull track position

- These two marks (minimum and maximum) illustrate the travel of the roller during the door swing, and thus must be within the pull track after mounting. For reference, a pull (with door opening 90 degrees), these two marks approximately 2 1/2" (64mm) apart. For door openings larger than 90 degrees, this distance will be larger.

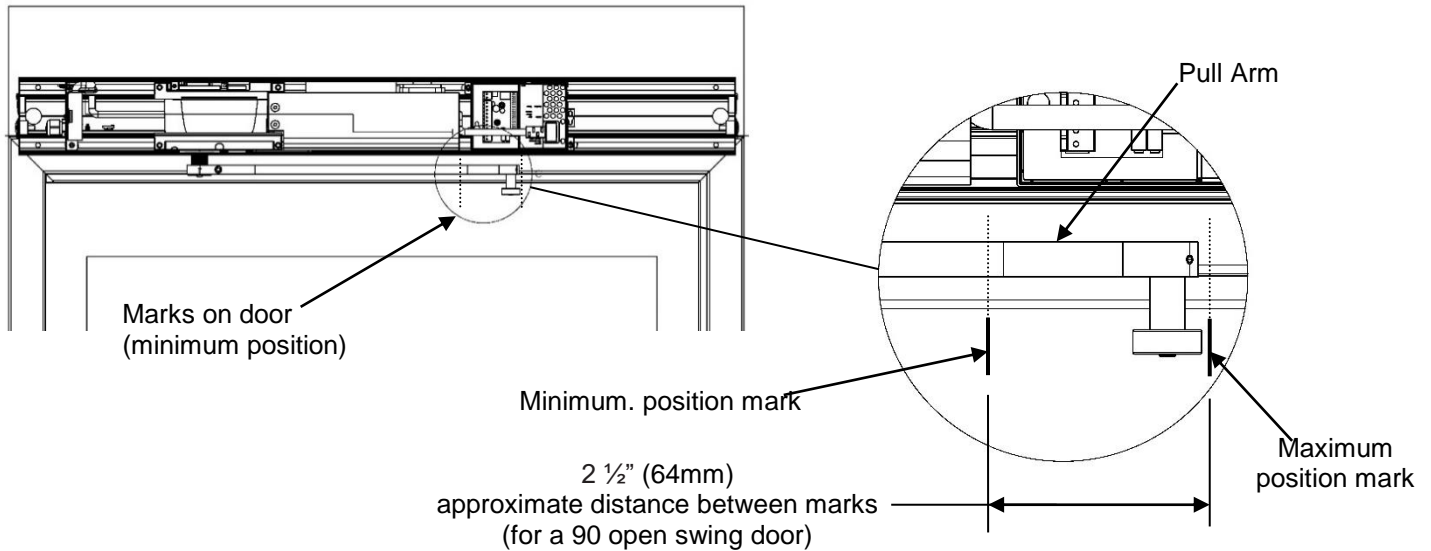

## STEP 4 - Fitting Pull Track

- Remove the two ends caps and fit the extended pull track to cover the 1st and 2nd mark.
- Fix to the door, using fasteners best suited for your door type. You may center the roller track in the door for visual aesthetics if the door width allows, but ensure the track covers the open and close marks for correct operation.



**For positive reveal installations the positive reveal spacer must be used. For reveals greater than 0 up to 1 9/16" (40mm) mount spacer on the 2 3/8" (60mm) side and on the 1 9/16" (40mm) side for reveals greater than 1 9/16" (40mm) up to 2 3/8" (60mm). Spacer fastener holes to be drilled on site and longer track fasteners required.**

- Re-attach the two end caps to hide the screws.

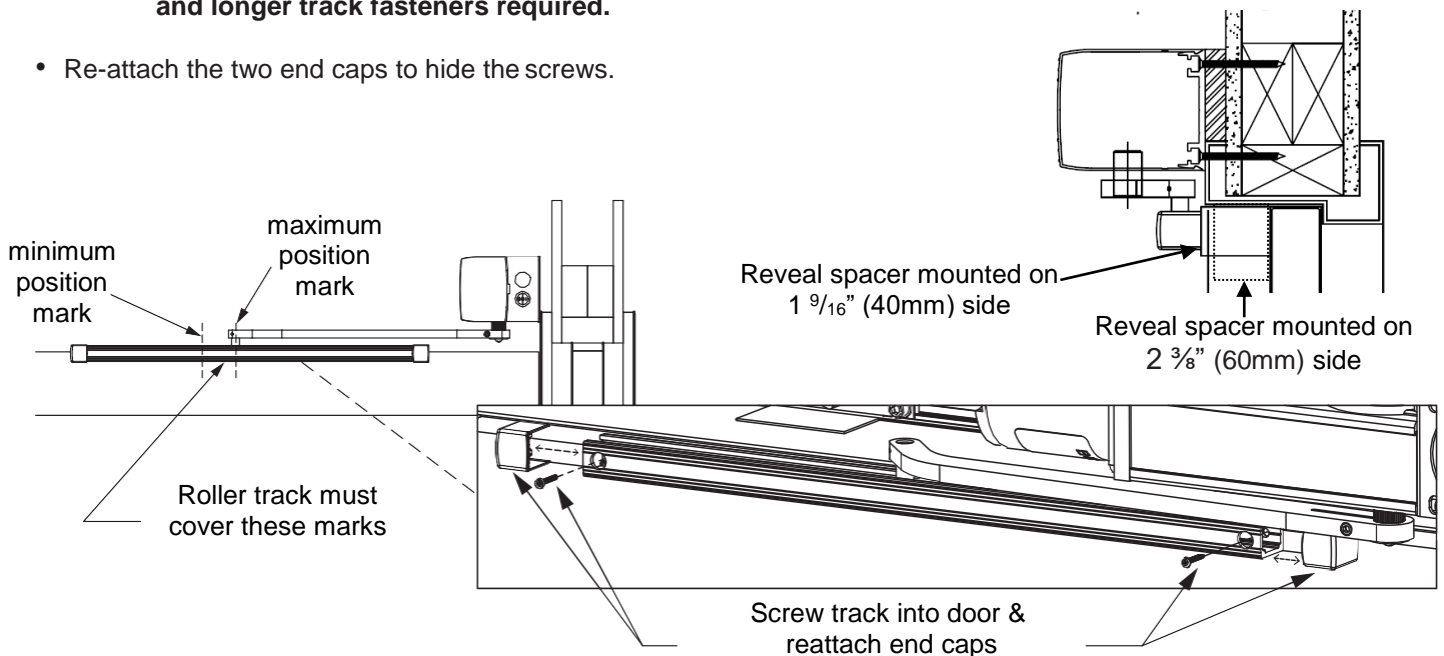

## STEP 5 - Attaching Pull Arm

- Attach the roller shaft to the arm as shown, making sure the set screw is tightened into the groove on the roller shaft. This will ensure that the arm and shaft do not dislocate during operation. For optimal performance, the roller should be in-between the track limits as indicated.
- Tighten the ¼"-20 x 7/8"L socket cap screw for the male and female splines to grip correctly.



Make sure Pull Track is installed level with the header. This is to ensure the roller stays inside the track during opening and closing, prolonging the life of the roller.

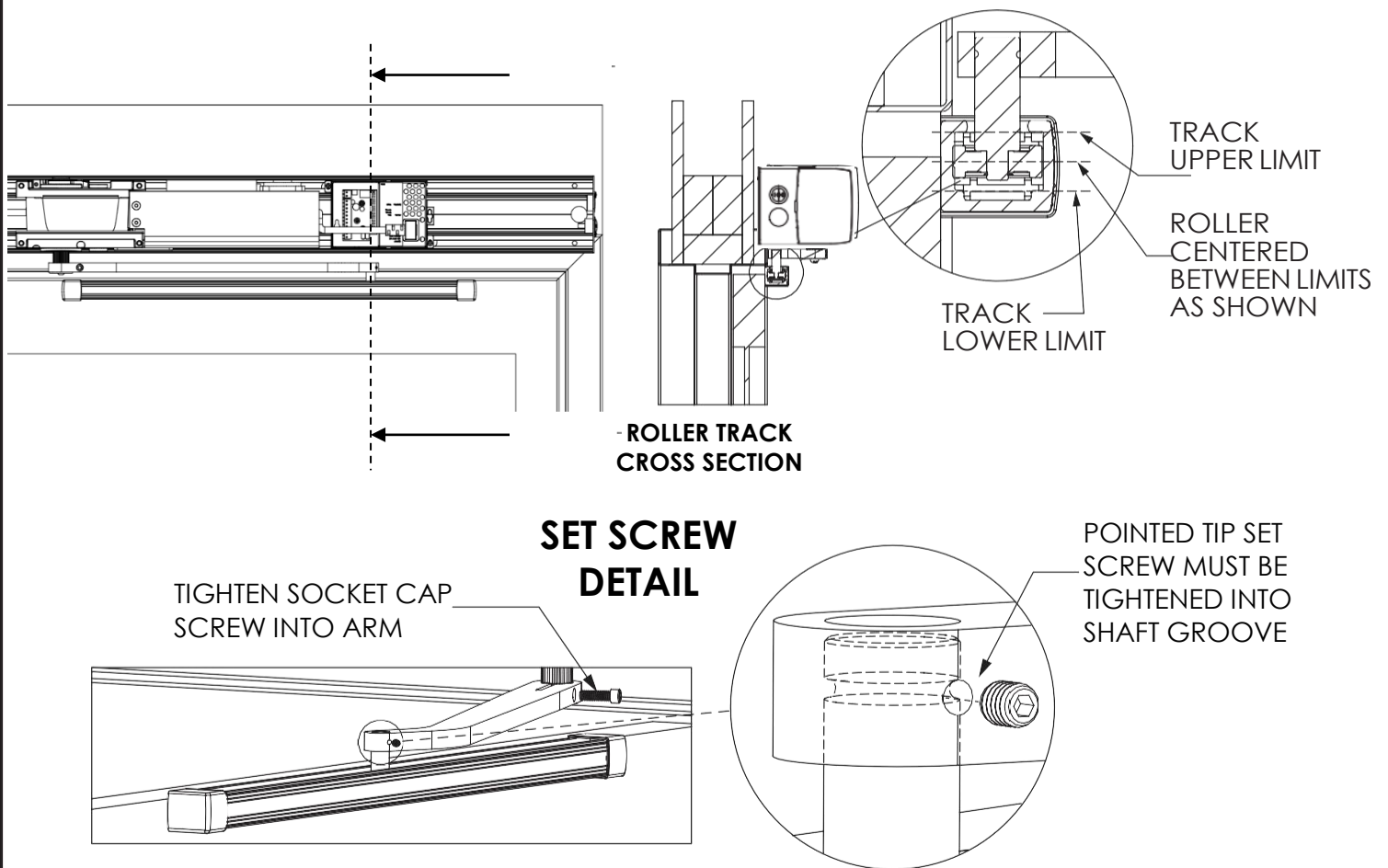

## 4.1 HA9 Control

- 1 The HA9 can be equipped with the standard extension unit EXU-SI and/or the optional EXU-SA, depending on the functions required. See page 11 or 12
- 2 Arm system selection.
- 3 Factory set arm configuration is PUSH, if PULL is required:
  - Switch power OFF
  - Select arm configuration
  - Switch power ON

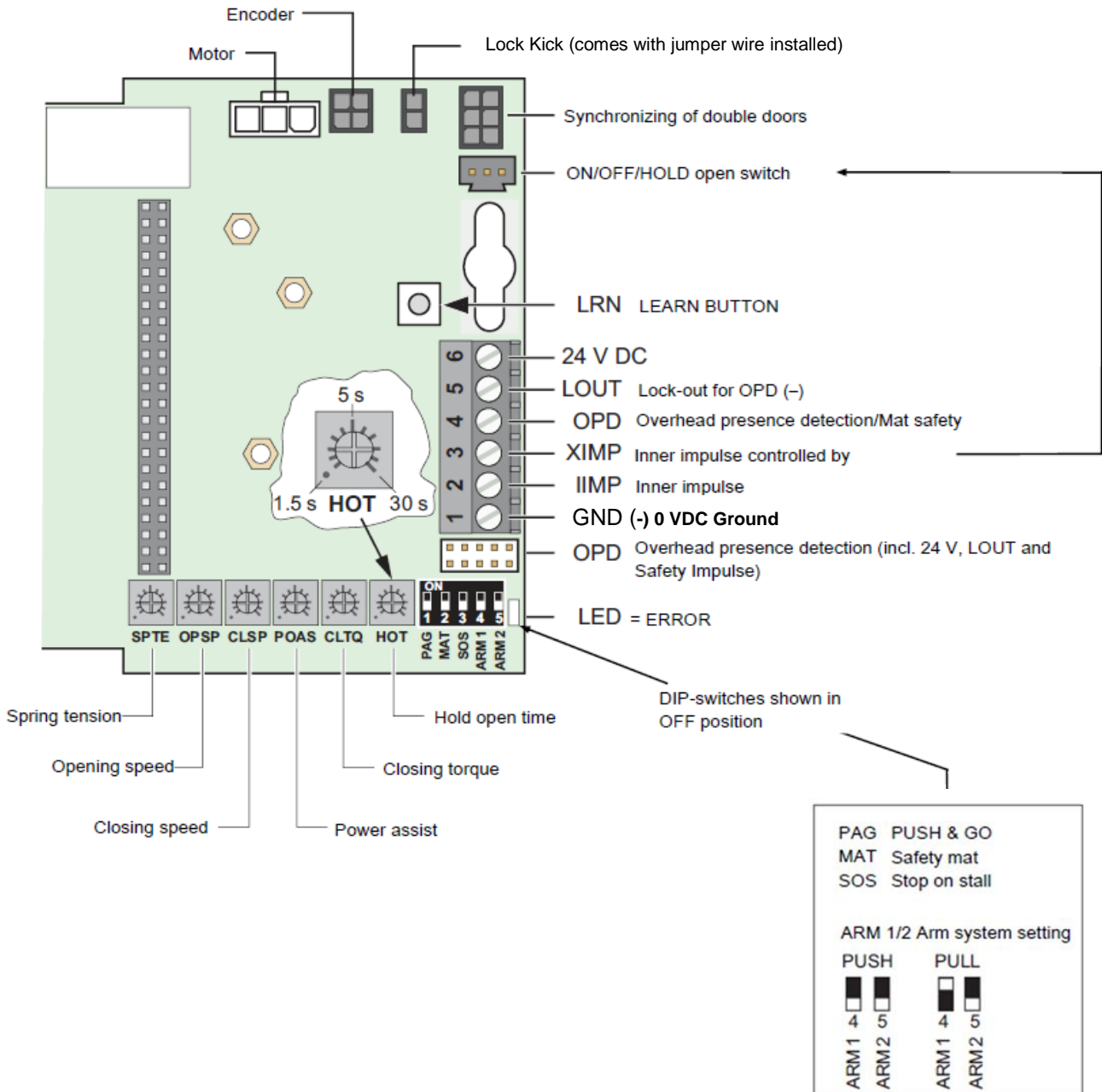

## 4.2 Extension units EXU-SI / EXU-SA

### Installation

To extend the functions, install the extension units to the control unit HA9.



The extension units can be mounted on top of the control unit HA9, separately or combined.

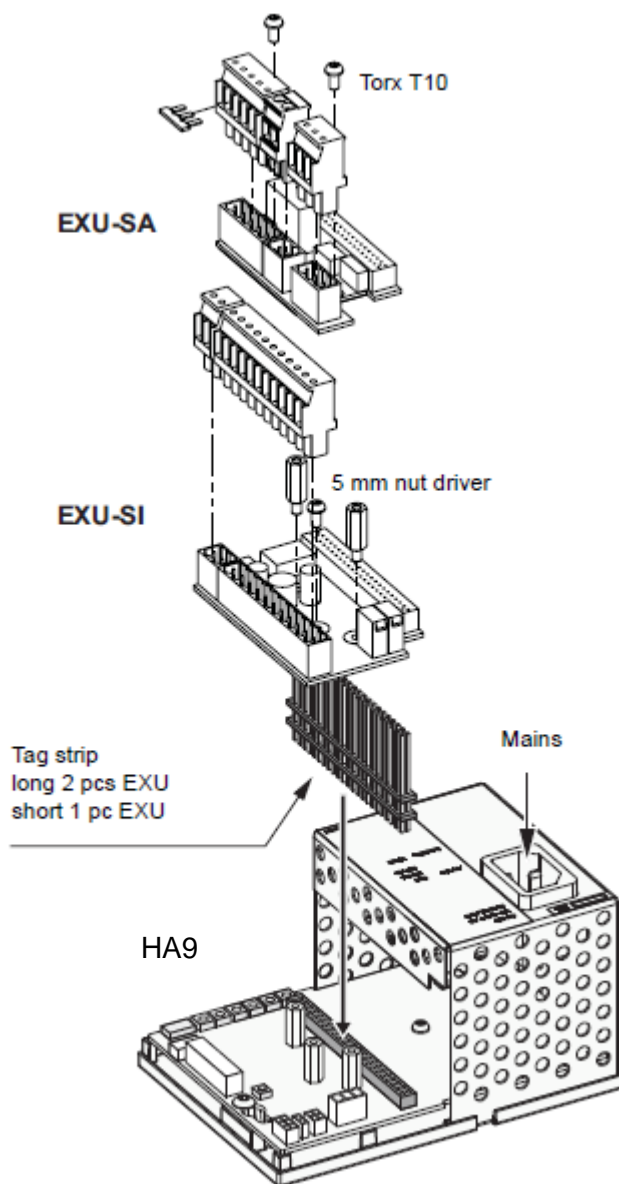

## 4.3 Extension unit EXU-SI (Standard)

### Functions

This extension unit has inputs for electro-mechanical lock, program selector, KILL function, OPEN/CLOSE, KEY opening and outer impulse.

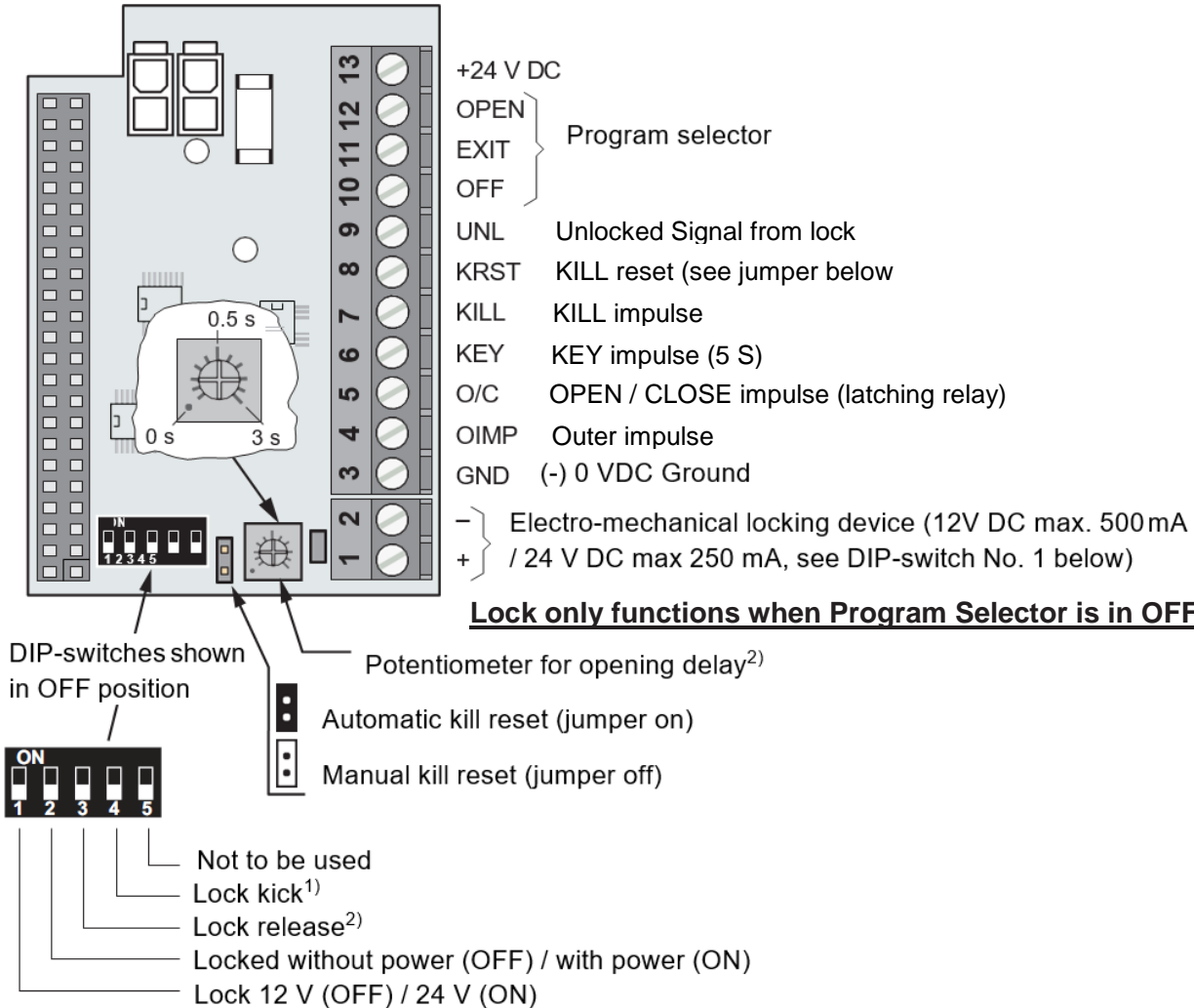

<sup>1)</sup> Independent of switch position (ON /OFF), the “latch check” complies with the ANSI A156.19 requirements. Position OFF: Smooth closing, to be used on doors without lock. Position ON: More powerful closing, to be used on doors with lock, to overcome binding in the locking device.



After changing any system selection a new LEARN must be carried out. With selection “Locked without power” is the lock energized from 0 to 10 degrees at opening. If a program selector is not used, a jumper is required from position 3 to position 11.

## 4.4 Extension unit EXU-SA (Optional)

### Functions

This extension unit has inputs for door mounted sensors, which can give presence impulse on approach side and/or presence detection on swing path side. Relay output for error indication, KILL output, Lock output or door indication is also integrated. When the jumper for the relay is set to 'Open door indication', its activation will follow the Blanking LED.

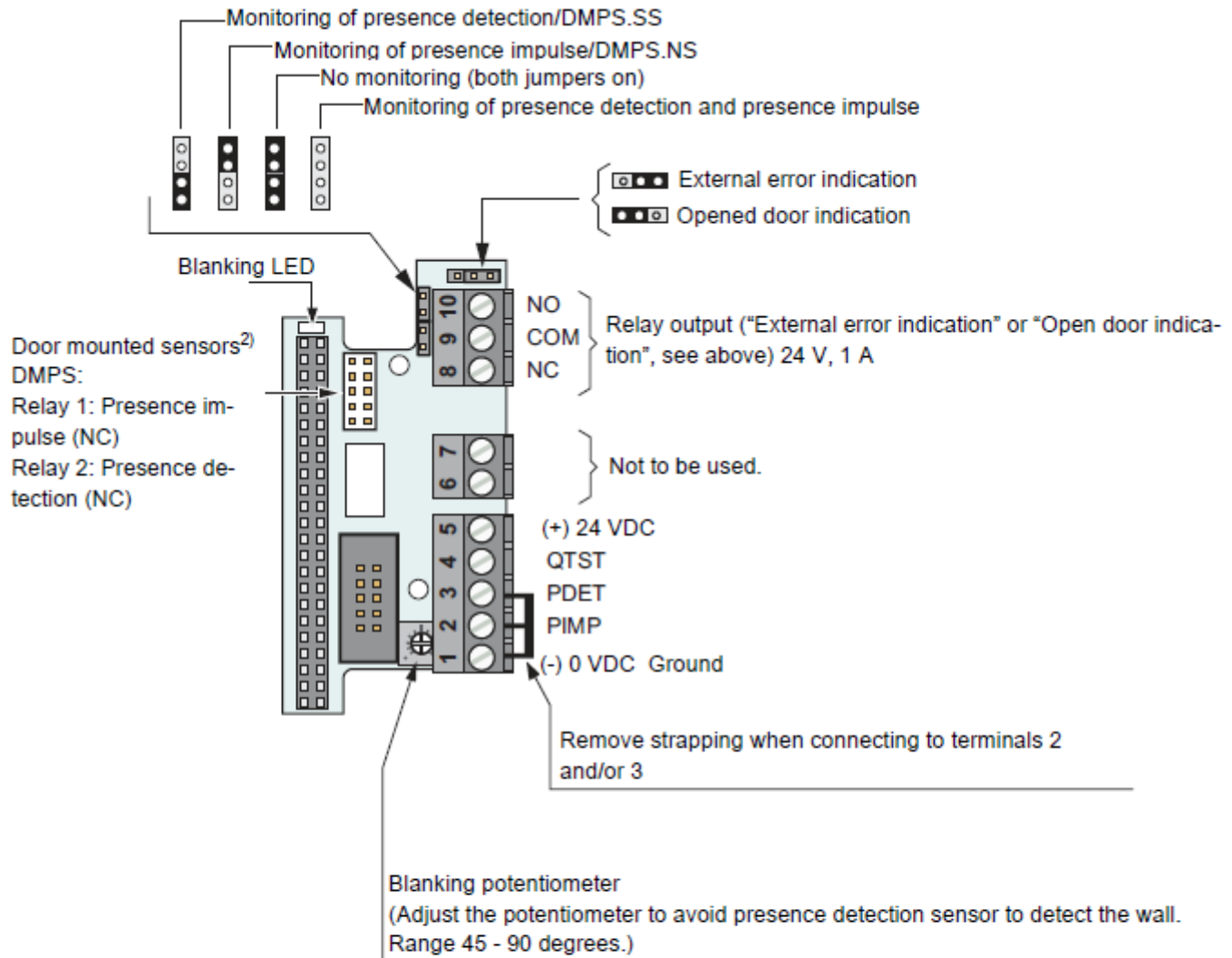

QTST = Sensor monitoring

PDET = Presence detection (NC)/DMPS.SS <sup>1)</sup>

PIMP = Presence impulse (NC)/DMPS.NS <sup>1)</sup>

<sup>1)</sup> If not used strap to "Ground".

<sup>2)</sup> Remove strapping from terminals 2 and/or 3.

## 5.1 Back Check and Latch Adjustment (door stop)

**Note:** If you are using the stop cam, it is strictly for set-up and interior applications only. For exterior applications, do not use as a physical stop.

### STEP 1

Close the door

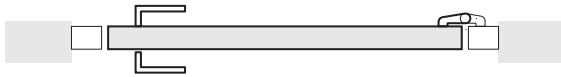

Impulses are not accepted if SPTE is more than 0°.

### STEP 2

Turn the potentiometer SPTE to 0° (if not already on 0°)

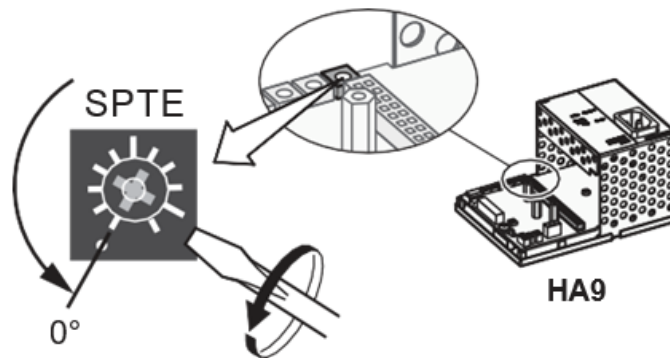

### STEP 3

Switch on the mains power (the operator will find its closed position)

### STEP 4

Open the door to required open position, plus approx. 5/8" (15 mm), by turning the potentiometer SPTE on the HA9, clockwise.

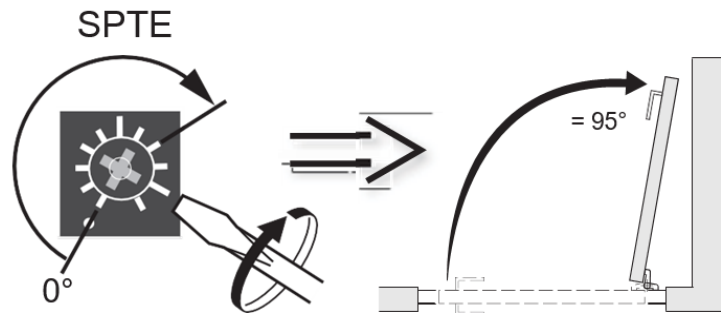

### STEP 5

Lift the lock kick cam and the door stop arm up, mount the stop arm on the splines, as close as possible to the stop block 1). Fine-adjust if necessary with the screw on the stop block 2).

1)

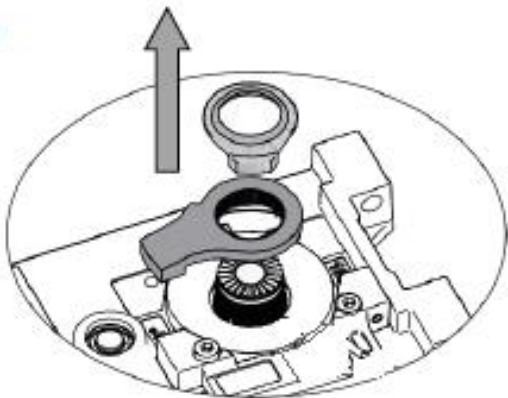

2)

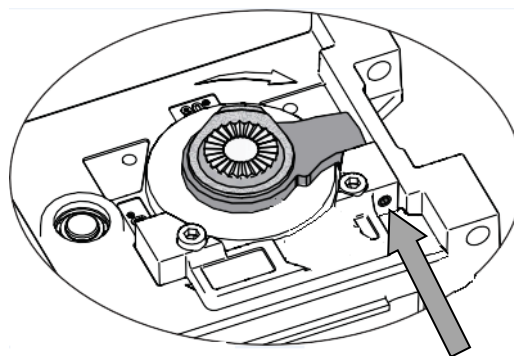

### STEP 6

Close the door by turning the potentiometer SPTE to 0° and let the door close.

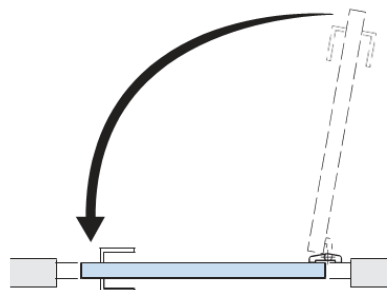
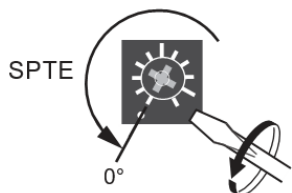



## 5.2 Micro Switch (Optional)

Control the lock kick by turning the lock kick cam (2) when power is off. This lock kick gives a lock kick at power failure for the last 3-10 degrees of closing to make sure that the door will fully close and latch.

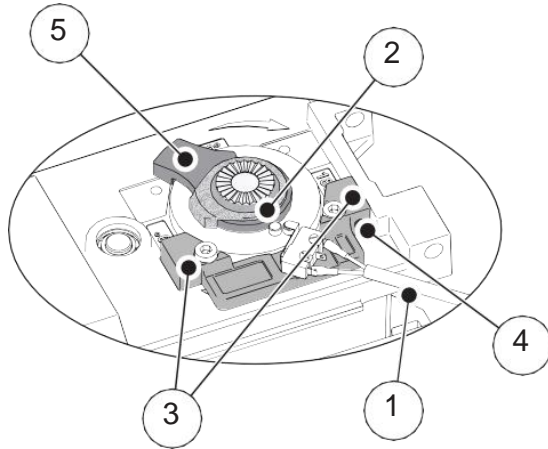

- 1 Micro switch
- 2 Lock kick cam
- 3 Stop block
- 4 Fine-adjustment screw
- 5 Door stop arm

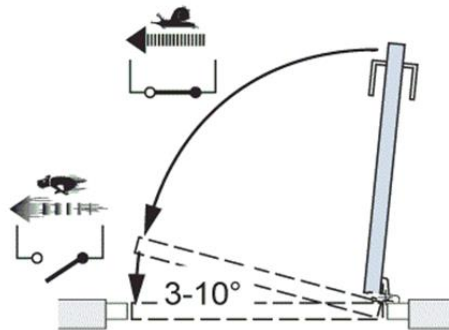
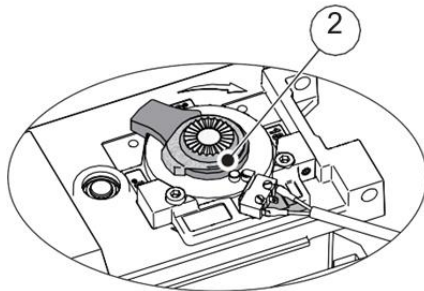

**This lock kick cam MUST be set-up correctly to ensure safe operation!**

## 5.3 Sync cable for double doors (synchronizing of 2 operators)

1. Connect a cable between Primary HA9 and Secondary HA9.

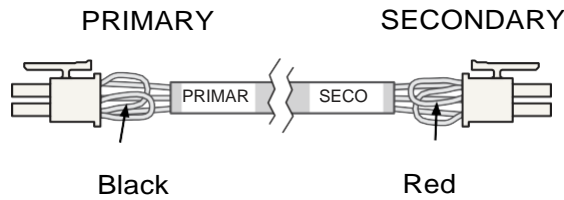

The connection/markings of the sync cable determines which of the operators is the **PRIMARY** and **SECONDARY**.

For a Rebated door the **Primary door** must **open** before the **Secondary door** and the **Secondary door** must **close** before the **Primary door**

2. Cut the jumper for double doors per the following table

Function		Door design		Cut the jumper with color	
Opening	Closing	Rebated	Jamming	PRIMARY side	SECONDARY side
Synchronous	Synchronous	No	No	No cutting	No cutting
Synchronous	Asynchronous	Yes	No	Cut black	No cutting
Asynchronous	Asynchronous	Yes	Yes	No cutting	Cut red
Double egress		—	—	Cut black	Cut red

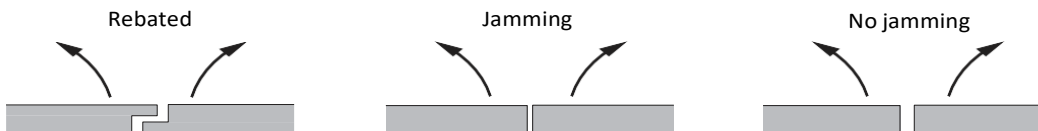

## Settings for double doors

Function	Settings on the	
	PRIMARY	SECONDARY
Common		
Program selection	X	
Opening time	X	
Closing time	X	
Hold open time	X	
Close / Continue to open when the door is obstructed	X	
PAG On/Off	X	
Level of Power assist	X	(X)*
Extended closing force	X	(X)*
OPD Impulse or Mat Logic Impulse	X	
Selection of operating mode during operation on battery power	X	
Individual		
Lock/Unlock signal voltage	X	X
Locked without/with power	X	X
Lock release Enable/Disable	X	X
Open Delay Time	X	X
Lock kick Enable/Disable	X	X

\* For "Double egress doors" these functions must be set separately for PRIMARY and SECONDARY as the arm systems as well as the air pressure may be different.



**Locks on the PRIMARY and SECONDARY doors must be connected to the control unit (HA9) on the corresponding operator.**

**Inner and outer impulses can be connected to either PRIMARY or SECONDARY HA9 or both.**

**The OPD is to be connected to the PRIMARY HA9 except for "Double egress", where each OPD must be connected to corresponding HA9.**

**Door leaf mounted sensors must always be connected to corresponding HA9.**

## 5.4 Auto-learn – automatically sets back and latch check (recommended)

This learning is performed by pushing the Learn button (LRN).

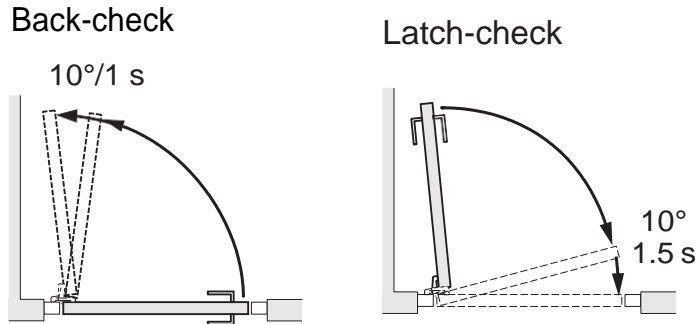

- Before the learning procedure starts, make sure that the door has been properly closed i.e., not by force.
- If any of the parameters "Spring pre-tension", "Closing torque" (CLTQ) and "Lock release" DIP-switch No. 3 on EXU-SI) are changed after performing a learn, a new learn must be carried out.
- Learn can be carried out with activation units and locks connected.
- The back-check will be automatically adjusted to 10° and 1 second before open position. The latch-check will be automatically adjusted to 10° and 1.5 seconds before closed position.

## 5.5 One push / two pushes on the Learn button (LRN)



Remain clear of swing path of door, as door may close rapidly. The door has no safety during auto-learn cycle.

### One push (delayed opening)

Push the button once. The door will open after 2 seconds and adjust the back-check and latch-check automatically.

### Two pushes (direct opening)

Push the button twice. As above, but the door starts to move directly.

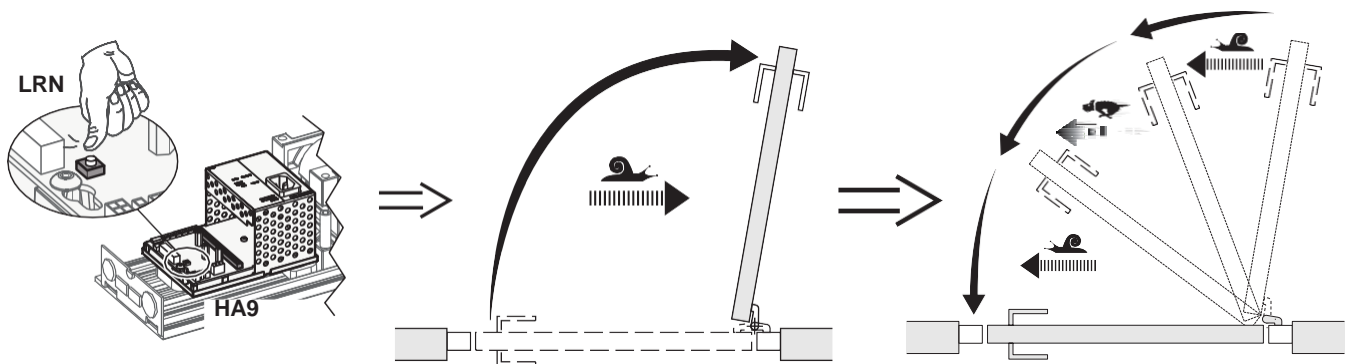

## 5.6 LRN Learn button for Double doors

For double doors, the Primary door must be learned first and thereafter the Secondary door. When the Secondary door is learned, the Primary door will open up to fully open position during the learning phase of the Secondary door.

The doors can also be learned separately before connecting the sync cable. In case of astragal doors and separate learning, the Primary door must be held open before the Secondary door learn is carried out.

## 5.7 Learn with advanced setting of “back- and latch-check”

See the prerequisites for performing a "learn" under the heading "Auto-learn - automatically sets back and latch check. (recommended)" on section 4.2

- 1 Push the button once or twice as for auto-setting.
- 2 Stop the door at required back-check.
- 3 The door reverts towards closed position.
- 4 Remove the stop.
- 5 Stop the door at required latch-check.
- 6 The door reverts to learn the fully open position.
- 7 Remove the stop.
- 8 The door reverts to closed position.

## 5.8 Revert to default values for “back- and latch-check”

See the prerequisites for performing a "learn" under the heading "Auto-learn - automatically sets back and latch check. (recommended)" on section 5.4

- 1 Disconnect the mains contact.
- 2 Press the "Learn button" and keep it depressed.
- 3 Connect the mains contact.
- 4 Watch the "Error LED" lighted for 3 seconds.
- 5 Release the "Learn button" after 3 seconds (LED is out).
- 6 The "Back check", "Latch check" and "Open position" have now reverted to default values.
- 7 Disconnect the mains contact.
- 8 Next time the mains is connected, the operator will use the default values.

## 5.9 General adjustment

- 1 Set the hold open time with the potentiometer on the control unit.
- 2 Adjust the opening speed (OPSP) to comply with ANSI A156.19. Turning clockwise increases the speed.
- 3 Adjust the closing speed (CLSP) to comply with ANSI A156.19. Turning counterclockwise decreases the speed
- 4 Connect the required activation units.
- 5 Check that the installation complies with AHJ (Authority Having Jurisdiction).

## 5.10 Reducing / Increasing the “Spring pre-tension” (SPTE)

The spring pre-tension is factory set to 210° and is normally not necessary to adjust. If adjustment has to be carried out see below.

- 1 Loosen the door stop arm. Remove if fitted on the topside, slide down if fitted on the bottom.
- 2 Turn the potentiometer for spring pre-tension (SPTE) clockwise until the door opens to 45°.
- 3 Loosen the drive arm fixing screw.
- 4 Moving the door towards open position, reduces the tension, or, moving the door towards closed position, increases the tension.
- 5 Tighten the drive arm.
- 6 Turn the potentiometer SPTE to 0°.
- 7 Open the door to required open position, plus approx. 5/8" [15 mm], by turning the potentiometer SPTE clockwise.
- 8 Mount the door stop arm as close as possible to the open door stop block, fine adjust with the screw if necessary.
- 9 Turn the potentiometer SPTE to 0°.
- 10 Push the learn button.
- 11 Let the door do the learn cycle without touching it.



**Max. allowable spring pre-tension is 210°. Over-tension may damage the spring or overheat the motor.**

## 6.1 Connection of Activation Units and Accessories

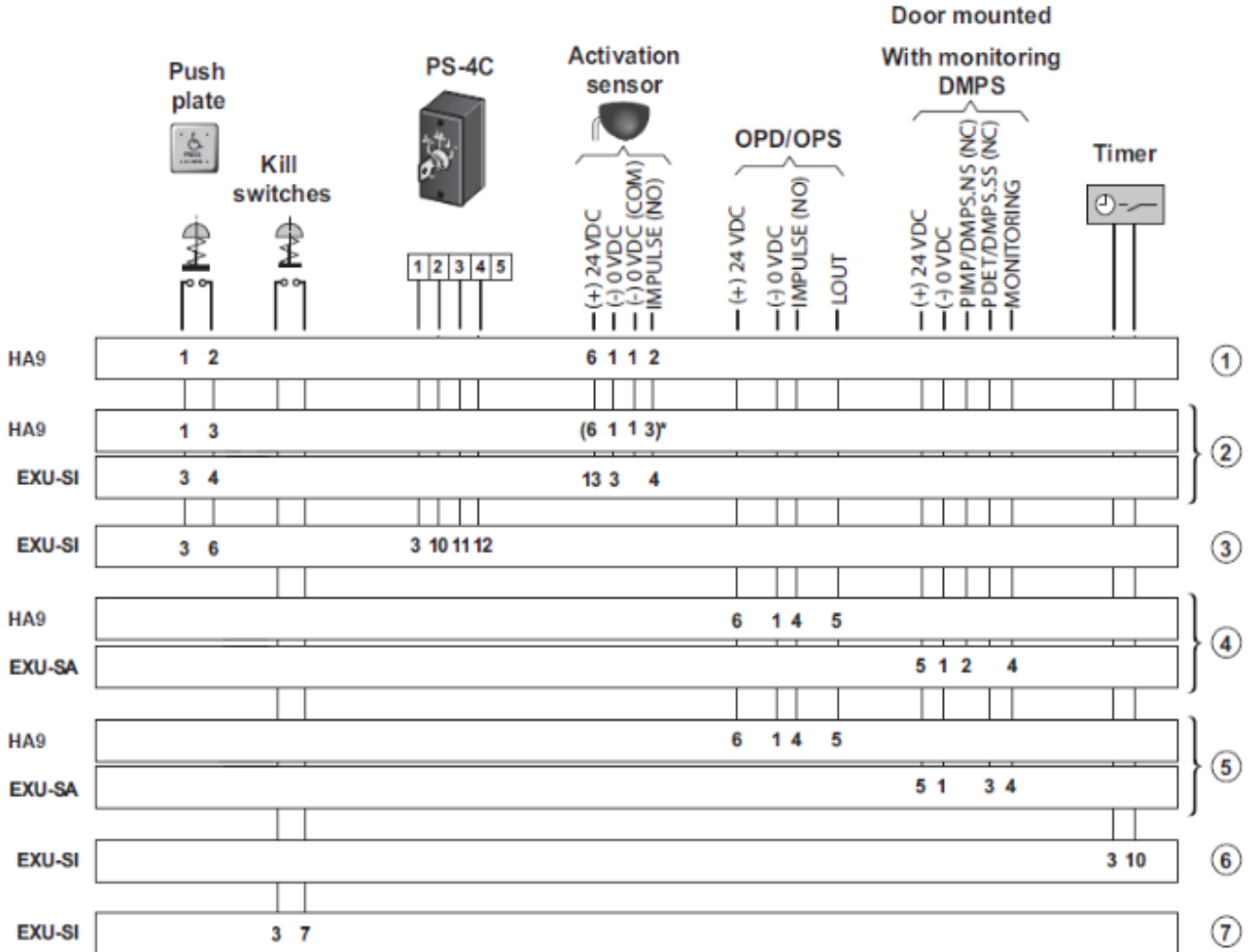

- ① Inner impulse
- ② Outer impulse
- ③ Key Impulse
- ④ Presence impulse/DMPS.NS
- ⑤ Presence detection/DMPS.SS
- ⑥ Off
- ⑦ Kill impulse
- \* Standard

**Note:**

If **Activation Sensor** is used the door will not comply with ANSI/BHMA A156.19.

## 6.2 Adjusting parameters

- 1 Disconnect batteries if any.
- 2 Disconnect the mains contact.
- 3 Press the "Learn button (LRN)" and keep it depressed.
- 4 Connect the mains contact.
- 5 Watch the "Error LED" flash 2 times for 3 seconds.
- 6 Release the "Learn Button" after the 3 seconds (LED is out). The "Error LED" flashes a number of short flashes that corresponds to the parameter group number (see table). After a short pause the LED will repeat the group number, and so on.
- 7 Pushing the "Learn button" once, increases the parameter group number. When the highest parameter group number is reached it will start with number 1 (default) again.
- 8 Push the button until you get the requested parameter group.
- 9 Disconnect the mains contact.
- 10 Next time the mains is connected, the operator will use the new group of parameters.

Parameter/Group	1 (default)	2	3	4	5	6	7	8	9	10
<b>OPEN/CLOSE HOLD OPEN TIME</b>	15 minutes	Infinite	15 minutes	15 minutes	15 minutes	15 minutes	15 minutes	15 minutes	15 minutes	15 minutes
<b>BATTERY mode (FUTURE USE)</b>	Power Save	Power Save	Convenience	Power Save	Power Save	Power Save	Power Save	Power Save	Power Save	Convenience
<b>KILL mode</b>	Locked during KILL	Locked during KILL	Locked during KILL	Lock follows program selector during KILL	Locked during KILL	Locked during KILL	Locked during KILL	Locked during KILL	Lock follows program selector during KILL	Locked during KILL
<b>OBSTRUCTION mode<sup>1)</sup></b>	Door closer	Door closer	Door closer	Door closer	Reverses when obstructed	Door closer	Door closer	Door closer	Door closer	Reverses when obstructed
<b>DOUBLE EGRESS mode</b>	Separate presence detection	Separate presence detection	Separate presence detection	Separate presence detection	Separate presence detection	Common presence detection	Separate presence detection	Separate presence detection	Separate presence detection	Separate presence detection
<b>LOCK RETRY</b>	On	On	On	On	On	On	Off	On	On	On
<b>OPEN/CLOSE impulse</b>	In AUTO mode	In AUTO mode	In AUTO mode	In AUTO mode	In AUTO mode	In AUTO mode	In AUTO mode	In OFF, EXIT and AUTO mode	In AUTO mode	In AUTO mode
<b>KILL Impulse Configuration</b>	Normally Open	Normally Open	Normally Open	Normally Open	Normally Open	Normally Open	Normally Open	Normally Open	Normally Closed	Normally Open

If set to "Reverses when obstructed", the operator re-opens when obstructed, similar to a presence impulse. As default the operator tries to close two times extra in automatic operation, Off or Exit mode and one time in manual operation, Off or Exit mode if there is a problem with binding striking plates. This function can be switched off (see "Lock retry" above).



**When changing group of parameters, normally only the Primary control must be configured in a double door application. When changing from or to group seven, both PRIMARY and SECONDARY must be configured.**



## 7.1 Overhead Presence Detection (OPD) Monitoring

- 1 Disconnect the mains.
- 2 Press the LEARN BUTTON (LRN) and keep it depressed.
- 3 Connect the mains.
- 4 Watch the ERROR LED, flash 4 times for 3 seconds each.
- 5 Release the LEARN BUTTON after 4 flashes (LED is out).
- 6 Identify the current monitoring  
The ERROR LED flashes an amount of short flashes that correspond to the status number after a short pause the LED will repeat the status number and so on.
- 7 Changing the status
- 8 If you push the LEARN BUTTON once, the status number will increase. When you have reached the highest status number it will start at number one again.
  - Push the button until you get the requested monitoring status, 1 = OFF (default), 2 = ON
  - Disconnect the mains
 Next time you connect the mains the operator will use the new status setting.
- 9 Recommended settings for sensor SP34-M

Sensor dip switch settings Dip 1 = ON  
 Dip 2-8 = OFF  
 Interface dip switch settings Dip 1, 4 and 7 = OFF  
 Dip 2, 3, 5, 6 and 8 = ON

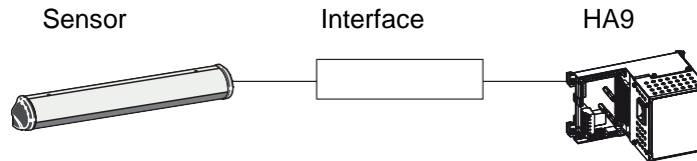

## 7.2 Lock Kick

- 1 Disconnect the mains.
- 2 Press the LEARN BUTTON (LRN) and keep it depressed.
- 3 Connect the mains.
- 4 Watch the ERROR LED, flash 5 times for 3 seconds each.
- 5 Release the LEARN BUTTON after 5 flashes (LED is out).
- 6 Identify the lock kick status  
The ERROR LED flashes an amount of short flashes that correspond to the status number after a short pause the LED will repeat the status number and so on.
- 7 Changing the status
- 8 If you push the LEARN BUTTON once, the status number will increase. When you have reached the highest status number it will start at number one again.
  - Push the button until you get the requested lock kick status, 1 = Basic (default), 2 = Enhanced
  - Disconnect the mainsNext time you connect the mains the operator will use the new status setting.

## 7.3 Lock Unlock

- 1 Disconnect the mains.
- 2 Press the LEARN BUTTON (LRN) and keep it depressed.
- 3 Connect the mains.
- 4 Watch the ERROR LED, flash 6 times for 3 seconds each.
- 5 Release the LEARN BUTTON after 6 flashes (LED is out).
- 6 Identify the current lock unlocked status.  
The ERROR LED flashes an amount of short flashes that correspond to the status number after a short pause the LED will repeat the status number and so on.
- 7 Changing the status.
- 8 If you push the LEARN BUTTON once, the status number will increase. When you have reached the highest status number it will start at number one again.
  - Push the button until you get the requested status, Lock is unlocked at
    - 1= Lock is unlocked when door is not closed.
    - 2= Lock is unlocked when door is 0-10 degrees from closed position, during opening.
  - Disconnect the mains. Next time you connect the mains the operator will use the new status setting.

## 8.1 Additional Components: Sensor(s) / Knowing Act Devices

### Safety Sensors

The control board can accommodate overhead and door mounted safety sensors. To permit safe passage through, the closing door will reverse (if equipped with door mounted safety sensor) to full open position, if an obstruction is encountered during the closing phase. If equipped with door monitor sensor, the operator will then resume its standard closing cycle and repeat when the obstruction remains.

- If equipped, the safety sensor on the closing side of the door will activate while the door is closing. The door will reverse to open.
- If equipped, the safety sensor on the opening side of the door is activated by another pedestrian while the door is opening, the door will stall until that pedestrian has left the opening area.
- If the door is equipped with an overhead safety sensor, the door will not open when there is an obstruction or pedestrian in the swing path.
- If the door is equipped with an overhead presence sensor in the closed position, the door will not open when there is an obstruction or pedestrian in the swing path.
- Superscans and Door Mounted Sensors can be directly plugged in and used.

### Jamb mounted switches

It can be used but are not practical for individuals using a wheelchair because of their range of motion (positioning their wheelchair to clear the door opening). (See Section 1.5) In a vestibule entrance a switch must be installed in the vestibule space to prevent entrapment and the doors can be sequenced to ease the traffic flow and limit the time of both doors being open to outside weather conditions.

### Push Plate or Knowing Act Devices

- Test the knowing act device. The door should swing smoothly to the open position and stop without impact. After a time delay (normally 1s to 5s) the door should close smoothly.
- Repeat on the other side of the opening if the door has two-way operation.
- If there is more than one push plate or Knowing Act Device on each side of the door, each should be tested.

## 8.2 Header Cover Installation

After all adjustments have been finished, the face cover (Cover Sticker must be covering the top machining) must be installed to the header box. Align cover over header back plate. Make sure side caps on the cover are aligned with in caps on header back plate, then push on. The cover will snap in place. Check for gaps all around to make sure cover is fully seated. To secure cover to back plate, use a #8 x 1/2" L Phillips-Tapping Screw on both the top and bottom sides of the cover located 1/2" (13mm) from the back edge, at center of the unit, see below.

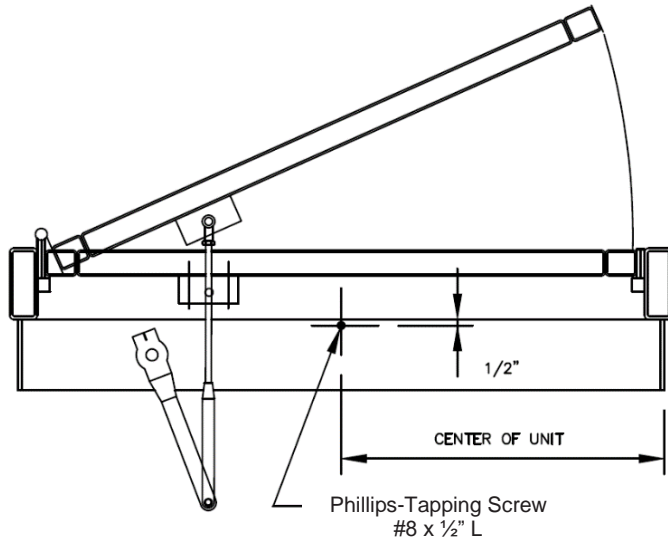

**Bottom View**

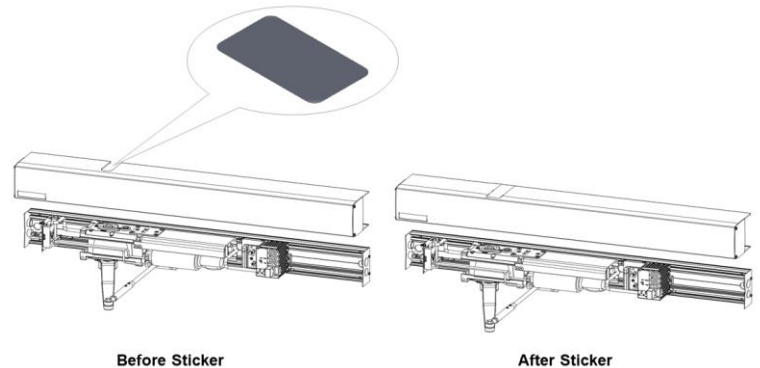

## 8.3 Safety Decals

Install all safety, traffic control, and instruction decals to the door as required. This is very important. Failure to do this leaves the installer **LIABLE** for any accident that might occur. This must be done!

A summary of the ANSI standard A156.19 requirements for safety decals is as follows:

Each decal shall be mounted on the door at a height of  $50 \pm 12$ " ( $1270 \pm 305$  mm) from the floor to the center line of the sign. The sign chosen will depend on the classification of the door operator.

Clean the area well before applying the decal. Remove the upper portion of the backing and roll the decal onto the door in a slow motion. Check to confirm the decal is straight. Use a fat edged soft spreader to smooth out the decal. Remove the lower backing from the decal and smooth out any air pockets.

After all adjustments have been finished, the face cover must be installed to the back plate by snapping cover into position.



### **WARNING!**

**Before leaving the job site,**

- **Clean up the work area**
- **Make sure all bolts are tight**
- **Clean glass**
- **Install safety decals**

**8.4 Safety Sticker Placement Example**

The center of the sticker height should be located at  $50 \pm 12$ " (1270  $\pm$  305 mm), above the finished floor. See ANSI standard A156.19 requirements for additional safety decal information. The center of the push plate height should be between 34" [864 mm] and 48" [1219 mm], above the finished floor.

LOW ENERGY STICKERS  
(ON BOTH INGRESS  
& EGRESS SIDES)

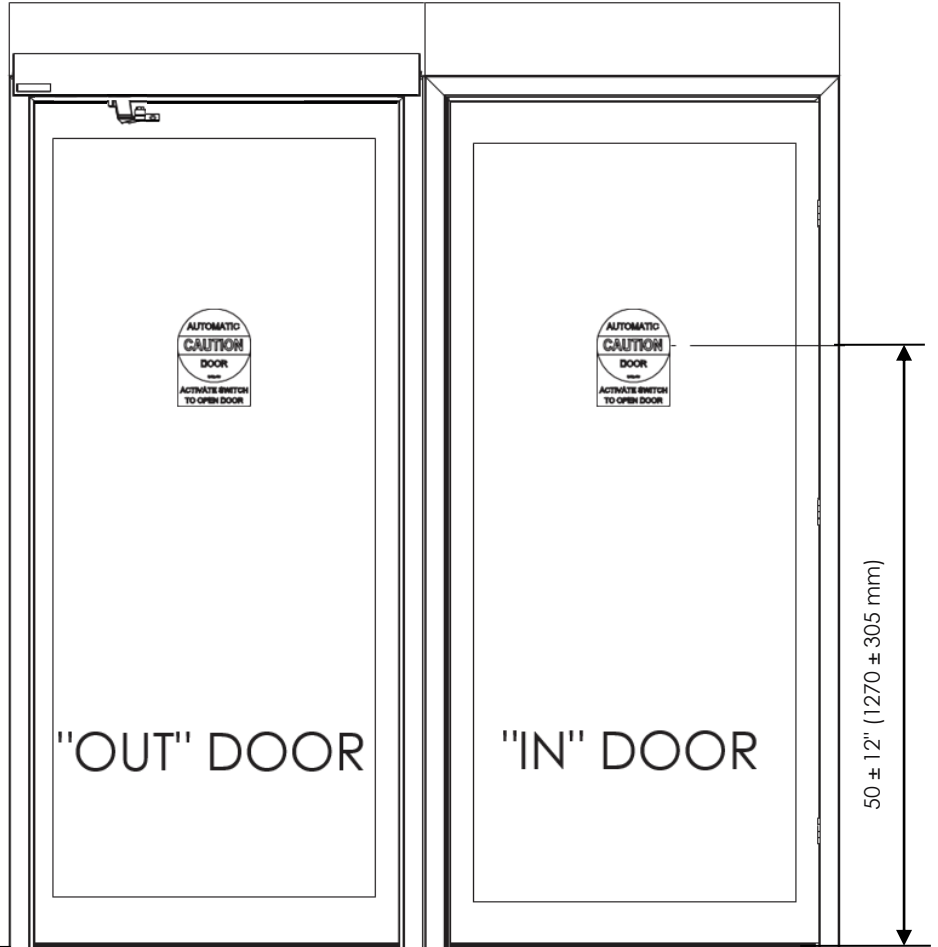
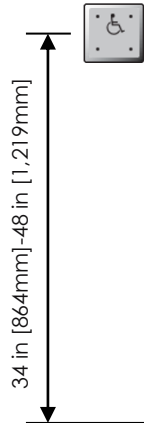

## 9.1 Common Faults

Fault	Possible reasons why	Remedies/Explanations
<b>The door does not open</b> The motor does not start	Control switch is set to OFF	Change the setting of the control switch
	Mains are missing	Check the mains switch
	Activation unit does not function	Strap impulse inputs
	Presence detection is activated	Check that there are no objects in the detection zone
	KILL activated	Deactivate KILL
	Potentiometer SPTE not turned to 0°	Turn SPTE to 0°
The motor starts	Mechanical lock is locked	Unlock the lock
	Something jammed beneath the door	Remove object
	Electric striking plate is binding	Select lock release
		Adjust striking
Arm system has come loose	Turn potentiometer SPTE until the door-stop hits the stop-block. Put the door in required open position. Tighten the arm system. Turn SPTE to 0°	
<b>The door does not close</b>	Control switch is set to HOLD	Change the setting of the control switch
	Presence impulse is activated	Remove objects in the detection zone
	Something jammed beneath the door	Remove object
<b>The operator has unknown spring pretension</b>	Too many adjustments carried out	<ul style="list-style-type: none"> <li>a Turn up the potentiometer SPTE until it is possible to loosen the door stop</li> <li>b Remove the door stop and the arm system</li> <li>c Unplug the mains and let spring close</li> <li>d Unplug the motor plug</li> <li>e Mount the drive arm from the arm system and find the o-pre-tension by moving back and forth</li> <li>f Loosen the arm</li> <li>g Connect the motor plug</li> <li>h Connect the mains</li> <li>i Turn the SPTE pot to 210° and wait until the spindle stops turning</li> <li>j Mount the door stop against the closing stop block</li> <li>k Turn down SPTE to 0° - operator is now factory set</li> <li>l Turn to section 5.1 to adjust open stop position</li> </ul>

## 9.2 Error Indication

- 1 During normal operation the ERROR LED on the control unit is illuminated.
- 2 An extinguished LED indicates that there is no mains.
- 3 A flashing light on the LED indicates that the operator is out of function (see table below).
- 4 An audible warning signal can be achieved by using the accessory board AIU. It is connected to the 24 VDC and plugged into the EXU-SA relay output terminal.

LED flash frequency	Reason	Remedy
One 0.3 s flash, pause etc.	+ 24 V DC external error or sensor monitoring error	Check for short circuit or broken monitored sensor
Three 0.3 s flashes, pause etc.	Control unit defective	Replace control unit
Four 0.3 s flashes, pause etc.	Encoder error	Check the encoder cable. Open and close the door manually and thereafter check the automatic function. If the operator is still out of function replace the drive unit.
Five 0.3 s flashes, pause etc.	Locking device defective	Check for e.g. short circuit in the locking device Replace locking device
	EXU-SI board defective	Replace EXU-SI board
Six 0.3 s flashes, pause etc.	Sync cable not connected or defective (double door only)	Connect the sync cable
		Replace the sync cable
Seven 0.3 s flashes, pause etc.	SECONDARY control unit defective (double door only)	Check the flash frequency on the SECONDARY LED and take necessary measures in accordance with this table.
Eight 0.3 s flashes, pause etc.	Motor overheated	Wait for the motor to cool down
Nine 0.3 s flashes, pause etc.	Blocked door and constant impulse	Toggle impulse

## 10.1 Service/Maintenance

Regular inspections shall be made according to national regulations and product documentation by a Ditec Entrematic - trained and qualified technician. Regular scheduled maintenance should be in accordance with national requirements and product documentation. This is especially important when the installation concerns a fire-approved door or a door with an emergency opening function.

As with all other electro-mechanical products, an automatic door requires regular maintenance and service. It is essential to know the importance of regularly scheduled maintenance to have a reliable and safe product.

Regular service and adjustments will ensure a safe and proper operation of an automatic door unit.

The "Service Log Book" shall be used together with the "Site Acceptance Test and Risk Assessment" document (PRA-0007) provided. Keep both documents available for maintenance and service records.



## 11.1 Manufacturer and Shipping Address

**Entrematic Canada Inc.**

221A Racco Parkway

Vaughan, ON

L4J8X9

Toll Free: 1-877-348-6837

Local: 905-886-8160

Fax: 905-886-7656

Email: info.ditec.ca@entrematic.com

**Entrematic USA Inc.**

1900 Airport Road

Monroe, NC 28110 USA

Toll Free: 1-866-901-4284

Local: 704-290-0980

Fax: 704-919-5014

Email: info.ditec.us@entrematic.com

**Entrematic Technical Service Department**

Toll Free: 1-833-921-1337

**Series Model: HA9****HA9 Installation Manual Part# 1019956****Code & Standard**

The operator complies with the following codes and standards:

- UL STD.325 & ANSI/BHMA STD. A156.19; Fire rated UL STD. 10 (b); UL STD. 10(c); NFPA STD. 252
- CAN/CSA STD. C22.2 NO. 247 & CAN/ULC STD. S104

All the rights concerning this material are the exclusive property of Entrematic Group AB.

Although the contents of this publication have been drawn up with the greatest care, Entrematic Group AB cannot be held responsible in any way for any damage caused by mistakes or omissions. We reserve the right to make changes without prior notice.

Copying, scanning or changing in any way is expressly forbidden unless authorized in writing by Entrematic Group AB.

# Dítec

---

## ENTRE//MATIC

**Entrematic Canada Inc.**  
Toll Free: 1-877-348-6837  
[info.ditec.ca@entrematic.com](mailto:info.ditec.ca@entrematic.com)  
[www.ditecentrematic.ca](http://www.ditecentrematic.ca)

**Entrematic USA Inc.**  
Toll Free: 1-866-901-4284  
[info.ditec.us@entrematic.com](mailto:info.ditec.us@entrematic.com)  
[www.ditecentrematic.us](http://www.ditecentrematic.us)