



## TURTLE BACK TB100 HYDRAULIC GATE CLOSER

The LockeyUSA **Turtle Back TB100** is a hydraulic gate closer designed to push a gate closed with adjustable hydraulic speed control. Before installing the **TB100**, please read instructions completely and confirm that the gate is in good working order and operates smoothly. If not, repair gate before mounting the **TB100**.

### MOUNTING INSTRUCTIONS:

The LockeyUSA **Turtle Back TB100** must mount on the hinge side/pull side of the gate in order to push the gate closed. The **TB100** works best if the gate has in-line/flush/butt hinges flush with the gate post with 1" or less gap. For gates with offset hinges or more than a 1" gap, modifications will be needed to use the **TB100**. Visit [www.LockeyUSA.com](http://www.LockeyUSA.com) for more options and full line of hydraulic gate closers and gate security products.

### INSTALLATION INSTRUCTIONS:

1. □ Place **Anchor Bar** on the gate with **Hinge Bracket** on post (works on left or right hand gates by reversing hinge bracket).  
□ Align the edge of the **Hinge Bracket** with the edge of the gate post.  
□ Mark and then drill a 3/16" hole in any of the four **Hinge Bracket** holes and insert and tighten one **1-1/2" screw**.  
□ If the wood post is round, the **Hinge Bracket** must be mortised into the wood post for firm mounting.

2. □ With the **Hinge Bracket** attached and the gate closed, swing and hold the **Anchor Bar** against the gate and trace the outline of the **Anchor Bar Slot**.  
□ Swing back the **Anchor Bar** and mark a vertical line 3/4" back from the end of the **Anchor Bar Slot** (furthest away from hinge).

3. □ Center the **Anchor Connector Plate(B)** on the 3/4" mark.  
□ Mark the location of the two screws and drill 1/8" holes in the gate.  
□ Insert the **Clevis Pin(A)** into the vertical slot in the **Anchor Connector Plate** and attach the **Anchor Connector Plate** to the gate with two **5/8" screws(C)**.  
□ Place two **Slide Washers(D)** onto the **Clevis Pin**.  
□ Swing the **Anchor Bar** over the **Anchor Connector Plate** so the **Clevis Pin** goes through the anchor bar slot.  
□ Place the **Steel Washer(E)** onto the **Clevis Pin** and install the **Cotter Pin(F)** through the hole in the **Clevis Pin**.

**IMPORTANT: CHECK THAT THE BAR WORKS WITHOUT BINDING BY SWINGING THE GATE OPEN AND CLOSED. IF BINDING OCCURS, REMOVE SCREW AND REPOSITION.**

4. □ If the **Anchor Bar** assembly works freely without binding, finish installing the 3 remaining **1-1/2" Screws** into the **Hinge Bracket**.

5. □ Locate the **Speed Adjustment Knob** on the **Hydraulic-Spring Assembly**.  
□ With the speed adjustment knob facing up, align the **Hinge Knuckle** in between the **Hinge Bracket** and insert a **Hinge Bolt**.  
□ Secure with a **Nut**.  
□ Slightly open the gate to get the proper hinge alignment then connect the other **Hinge Knuckle** to the **Anchor Bar**.  
□ Insert **Hinge Bolt** and secure with a **Nut**.

6. □ Open the gate and remove the **Wing Key** from around the **Piston Rod**.  
□ Save the **Wing Key**, as it must be reused should it be necessary to remove the **Hydraulic-Spring Assembly**.  
□ Open the gate and allow the **Turtle Back** to close the gate.  
□ The **Speed Adjustment Knob** controls the closing speed of the gate. Rotate the speed adjustment knob clockwise to slow the speed of the gate during close, or counterclockwise to increase the speed of the gate during close.  
(Note: Turn Speed Adjustment Knob in 1/8 turn increments. Increase speed to overcome a lock set with a strong latch.)

7. □ Snap the **Cover** over the **Hydraulic-Spring Assembly** with the curved end up and the bent lip on bottom, as shown in Diagram 4. Your installation is now complete.

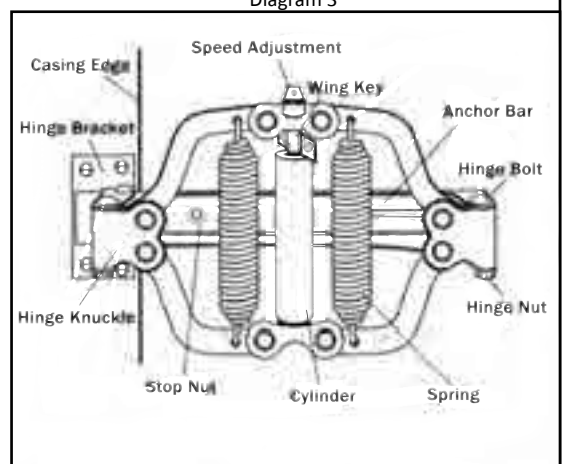
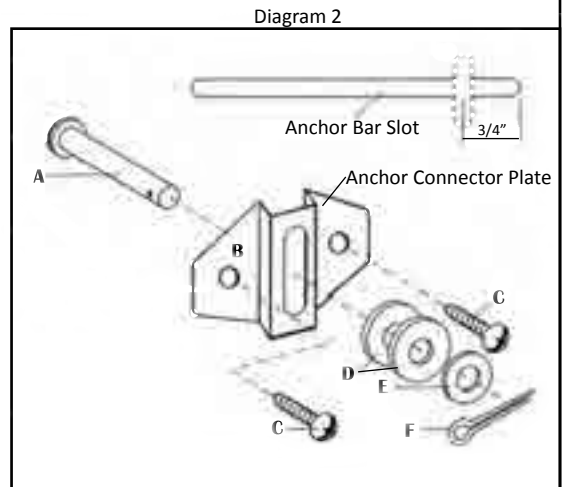
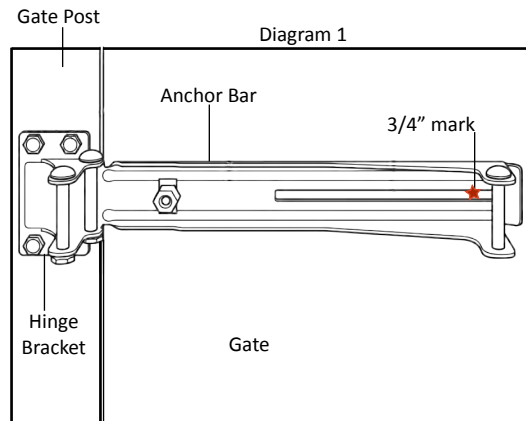

Note: A mechanical gate stop should be installed to prevent gate from over opening.



## TURTLE BACK TB100 HYDRAULIC GATE CLOSER



### ADDITIONAL MOUNTING INSTRUCTIONS (FOR CHAIN LINK & METAL GATES):

With so many types of gates—chain link, ornamental iron, etc.— the installer may need additional mounting plates (not included) to adapt to their application.

### ALTERNATE METAL POST INSTALLATION:

**Round metal post:** Weld an “L” angle or plate to the post so the mounting surface is parallel to the gate in the closed position. Align per instruction and clamp the **Hinge Bracket** to the new plate. Then bolt (not included) or weld into place.

**Flat or square metal post:** Locate desired mounting location, align **Hinge Bracket** per instructions and bolt or weld into place.

### ALTERNATE METAL GATE INSTALLATION:

Some metal gates do not have the proper mounting surface, such as a chain link gate. A wooden or metal strip (not included) wide enough to mount the **Anchor Connector Plate** (approximately 2”) will be needed. Bolt or weld the strip horizontally side to side across the gate’s wire mesh. Following the **Installation Instructions Step #3**, the **Anchor Connector Plate** can now be mounted to the gate, as shown in Diagram 5.

Diagram 4

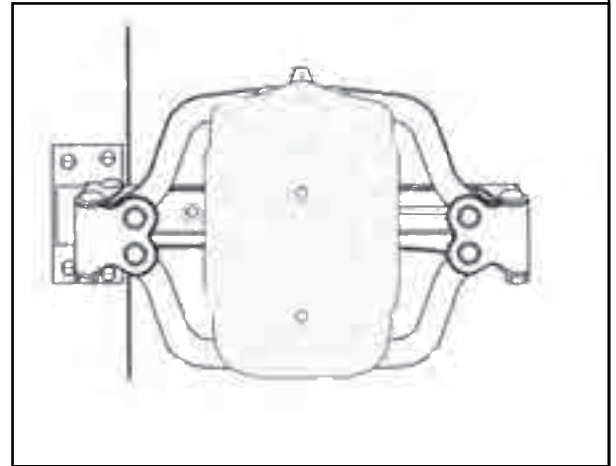
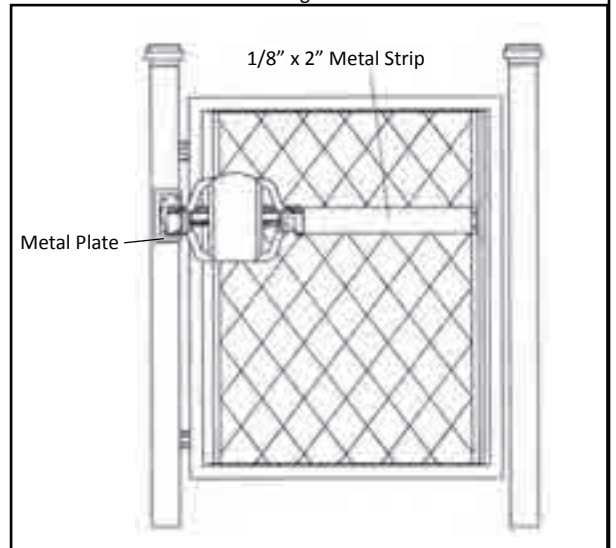

Diagram 5



### LIMITED WARRANTY:

LockeyUSA warrants the **TURTLE BACK TB100** for one (1) year from the date of purchase, only to the original purchaser, against defective material and workmanship. LockeyUSA's obligation under this warranty is limited to the repair or replacement, at its option, of the product or any parts thereof, when determined in good faith that the defect is due solely to materials and/or workmanship, and is conditioned upon payment by the purchaser of all transportation cost incident to such repair or replacement. Return the product or parts thereof, with proof of purchase date, to Warranty Department, LockeyUSA, 4245 S. Lincoln Rd., Mt. Pleasant, MI 48858. LockeyUSA reserves the right to levy a service charge for handling, packaging and refinishing the product or parts thereof. This warranty does not include the cost of any inconvenience or property damage due to the failure of the product, transportation damage, misuse, abuse, accidents or similar incidents. This warranty gives you specific legal rights and you may also have other rights which vary from state to state. This warranty replaces all previous warranties and is the only warranty made by LockeyUSA on this product. No other warranties, either verbal or written, are authorized.



Visit [www.LockeyUSA.com](http://www.LockeyUSA.com) for more gate security products.

