

Notes

1. Allow plus tolerance for clearance per ANSI A115.2.
2. Lock and latch case support by door manufacturer.
3. Plaster guard by door manufacturer.
4. Prepare for a #8-32 screw.
5. When a strike box is used, 9/64"
6. For 93KW locks, use the KD303 drill jig to ensure that through-bolts and levers are properly aligned.
7. For all electrified products that require concealed wiring, a 3/8" diameter raceway through the door is required.
8. Extend the latch bore to provide room for TCM connections. (1" dia x 3" deep)
9. For 3-3/4" and 5" backsets, position the vertical centerline of the lock appropriately.

Note #8
Prep TCM hole
(1" dia x 3" deep hole)

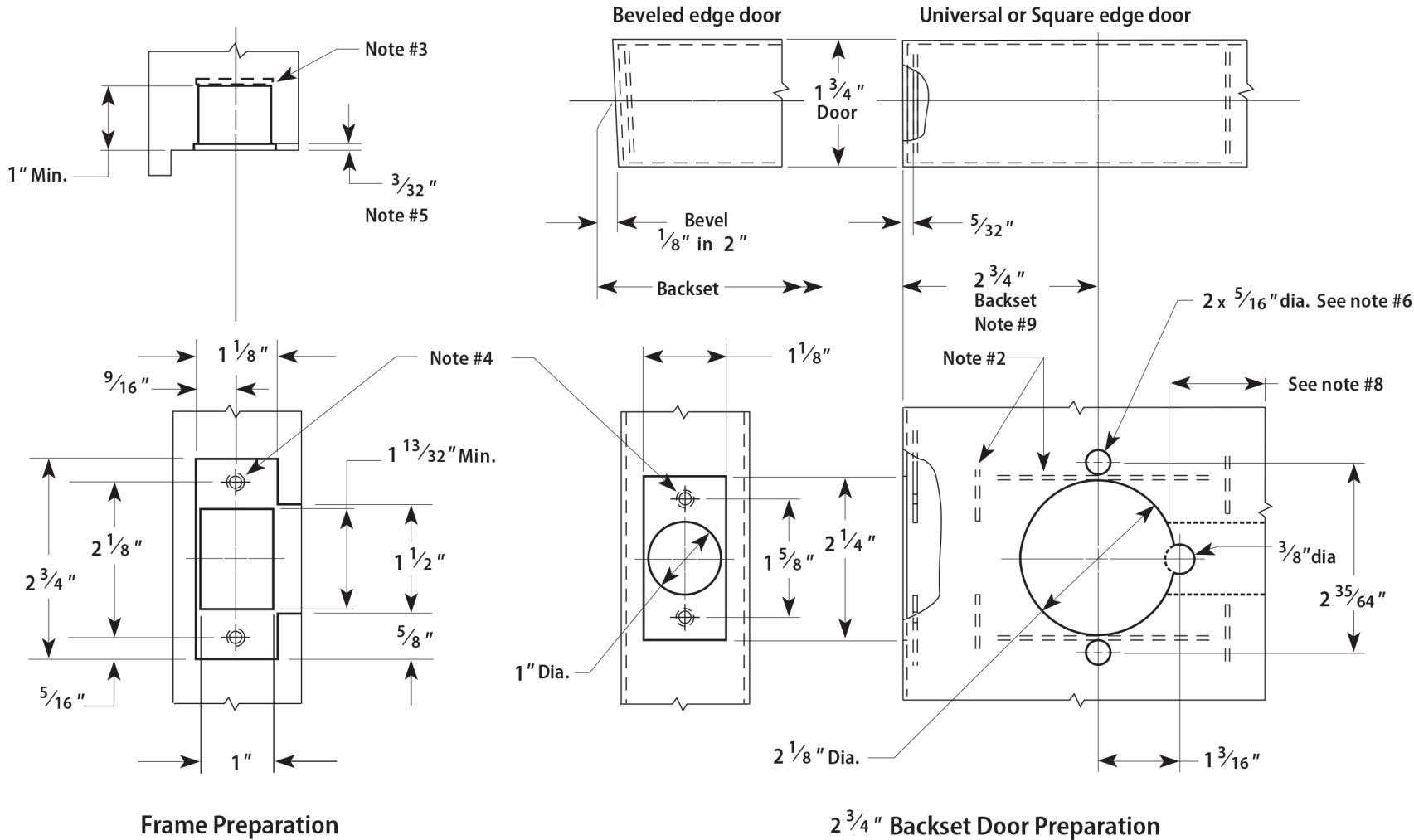
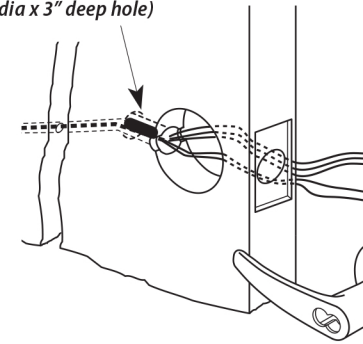

Frame Preparation

2 3/4" Backset Door Preparation

Title		Installation Specifications for	
Series		83KW & 93KW Electrified Cylindrical Locks	
83KW, 93KW	Backset	2 3/4"	
Functions		DEU, DEL	
Strike	Small ANSI strike (STK)		
Door thickness		1 3/4" - 2 1/4"	
Rev date		10/2015	
Template number		W20	
Rev		E	

BEST ACCESS SYSTEMS