

**R100H Reader
 Installation Instructions**

Package Contents

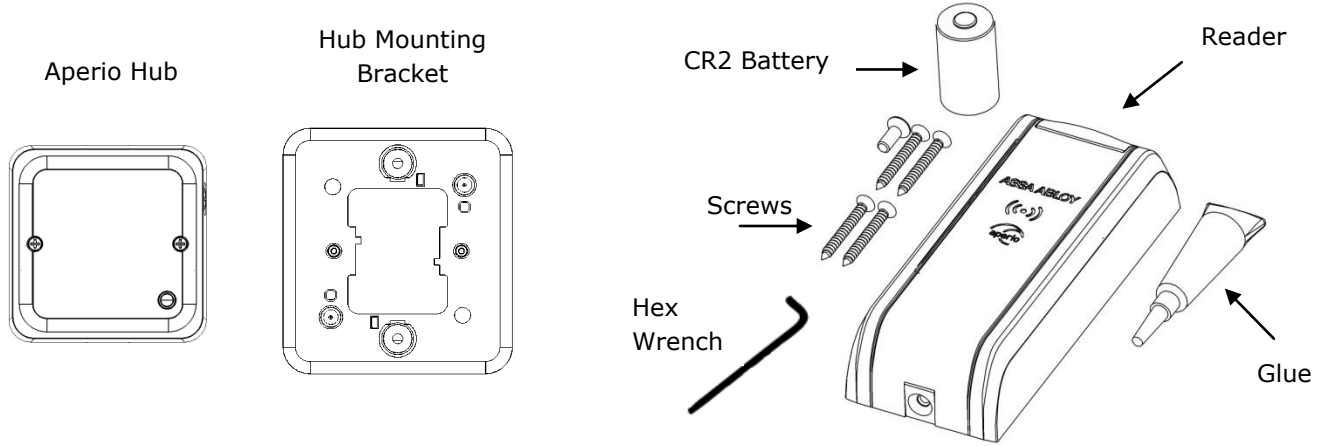

Recommended Tools

Approved Credential: i.e., iCLASS or Prox ID card	Level Pencil, wax pencil	Optional Dress Cover: R100-DCA Optional Clamping device
--	-----------------------------	--

Product Specifications

Hub Power Requirement: 8-24VDC, 250mA **Wireless Frequency:** 2.4 GHz, IEEE 802.15.4, using AES 128bit encryption
Lock Battery Type: CR2, providing 35,000 Cycles **FCC Part 15, Class B Compliant, Industry Canada, CE Compliant**
Reader Operating Temperature: -40F (-40C) to 122 F (+50C)
Credentials Supported: 125kHz Proximity or 13.56MHz iCLASS credentials are supported depending on reader model.

For technical support please call 1-800-624-5625

System Overview

The R100 wireless reader installs in locations where wiring may be difficult or undesired for aesthetic reasons. The R100 wireless reader connects to an access control system through the included communication hub. The communication hub connects to the access control system with wiegand wiring typical of a wiegand reader.

When a credential card is presented to the reader the request for access is sent wirelessly to the communication hub. The communication hub then communicates through wiegand wiring to the access control system where the decision is made to grant or deny access.

When access is granted the access control system unlocks the locking device separately.

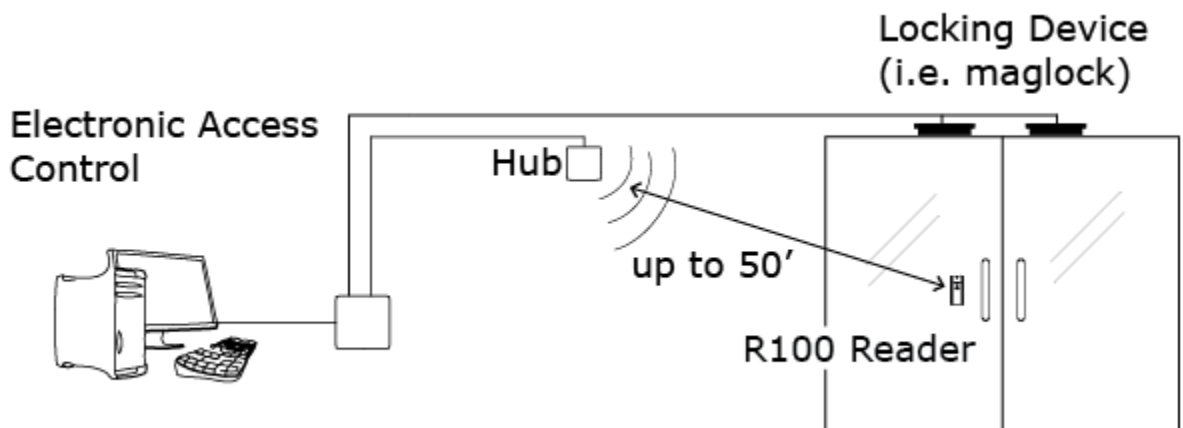

Installation Steps

1. Locate and Mount the Hub

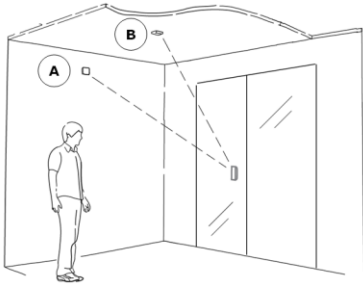

2. Connect the Hub

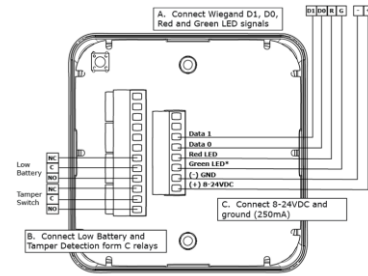

3. Insert Battery

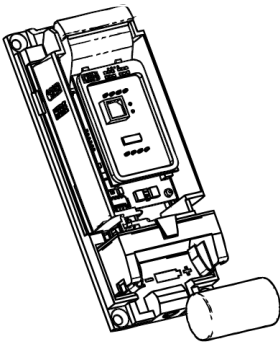

4. Mount Unit

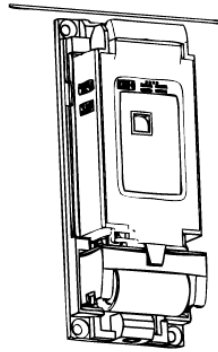

5. Reattach Cover

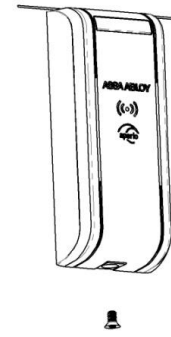

1. Choose the hub location

It is recommended that the hub be mounted near the top of a wall or on the ceiling to reduce potential for interference.

For a stable and reliable radio link, it is recommended that the hub is located within fifty (50) feet of the lock. A maximum of two interior walls between the hub and lock is recommended.

Recommended locations:

- A: Wall Mount
- B: Ceiling Mount

For a glass entryway the hub should be located in the interior lobby.

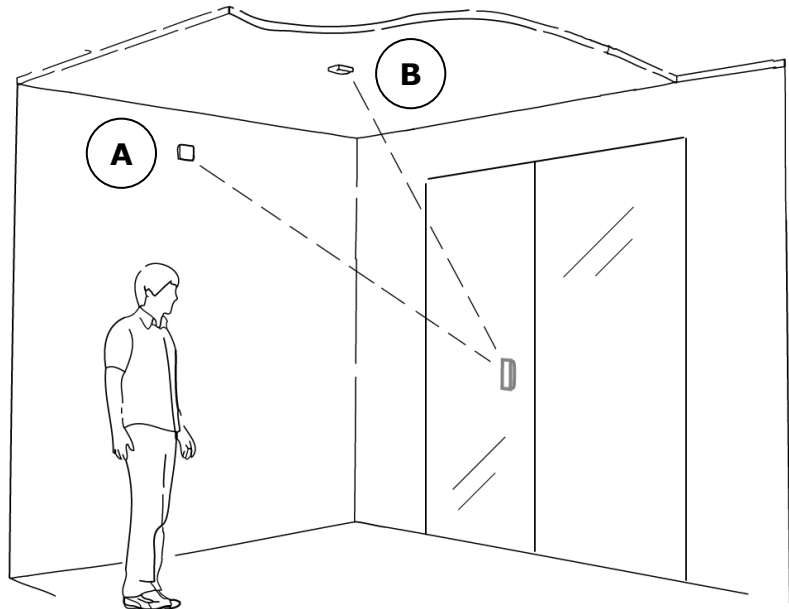

*Note the hub is not rated for use in plenum air spaces.

2. Mounting the Hub.

The included adapter plate can be used to mount the hub on a single or double gang box.

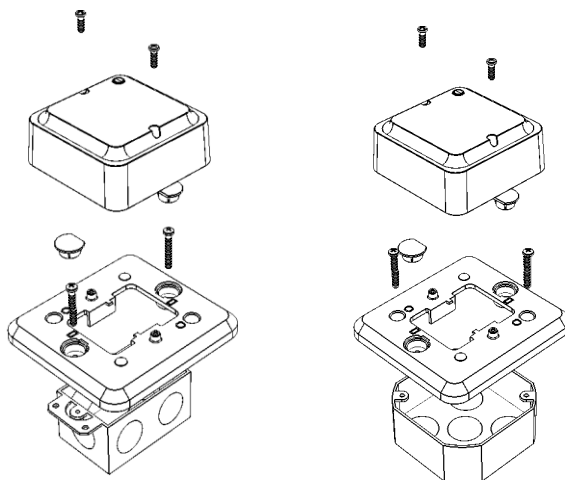

Mounting the Hub

3. Wiring the Hub.

The Aperio Hub connects to the Access Control system via Wiegand wiring. The hub requires 8-24VDC power (250mA). The hub includes two form C relays that can be used to transmit low battery signal and a tamper signal.

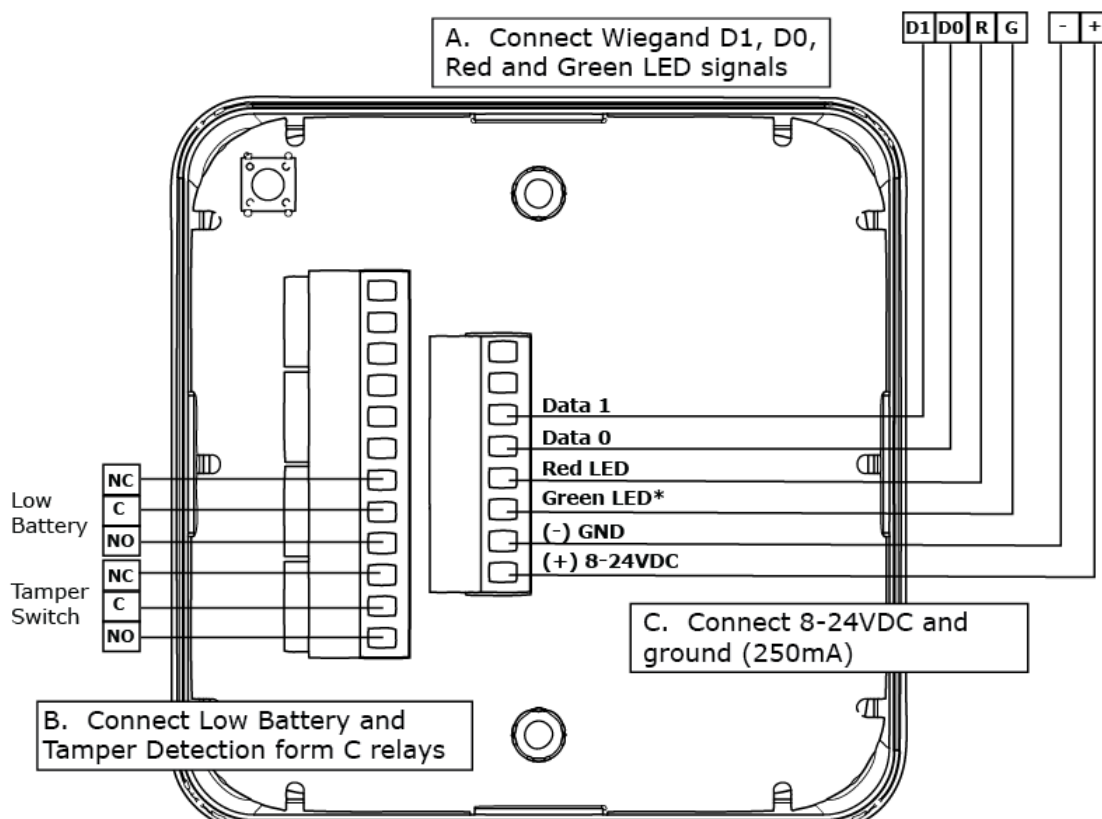

***Note:** the **Green LED** and **Red LED** inputs control feedback that will be displayed at the reader for approved access (Green) or denied access (Red).



Wiring the hub

4. Preparing the R100

Before starting, we recommend using a level to mark the position. Hold the reader body on the outside of the window and position it generally where you would like it to mount.

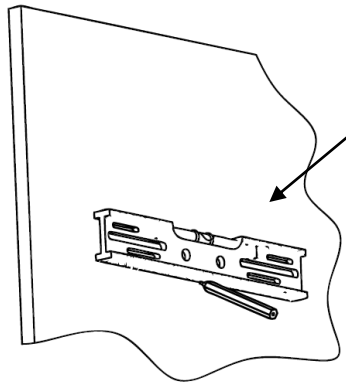

Use a pencil to mark this point on the window

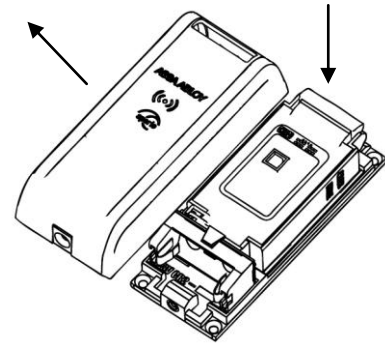

Pull the cover up while pressing on the LED

5. Insert Battery

Install the battery, ensure correct orientation. The reader will self test and beep once.

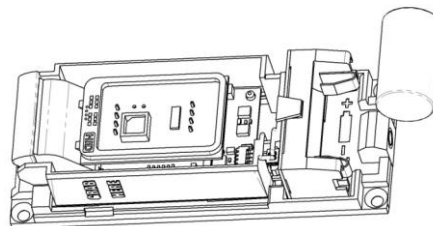

Battery

6. Mounting the Unit

The R100 can be mounted using glue or wood screws based on your needs.

6a. Apply Glue

It is recommended that a thin thread of glue is applied to three sides of the back-plate as shown. This allows oxygen to enter and aid in the curing process. Do not use tissue or a brush to spread the adhesive.

Quickly affix to the pre-marked area and hold or clamp until the adhesive has bonded (at least five seconds) The seal becomes functional within a short time and permanent after 24- 72 hours.

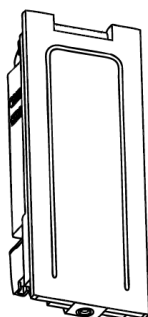

Glue line

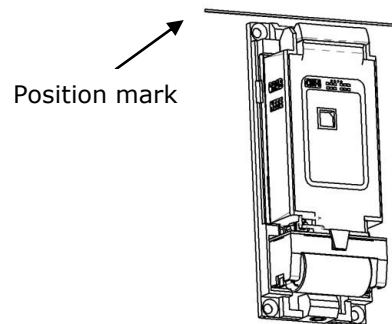

Position mark

Note the rate of cure depends on the ambient relative humidity. The best results are achieved when the relative humidity in the working environment is 40-60% at 22°C. Lower humidity leads to a slower cure. High humidity accelerates it, but may impair the final strength of the bond.

6b. Mounting with wood screws

This is an alternate method for mounting the R100 to your door.

Separate the components by gripping the electronic module at the noted side areas. Rock up, pull down, and lift out.

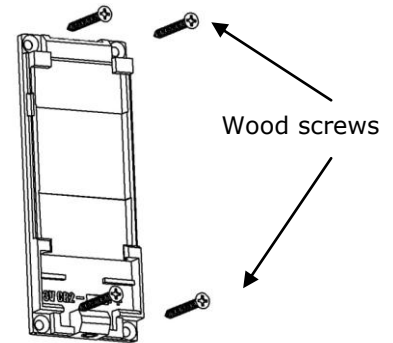
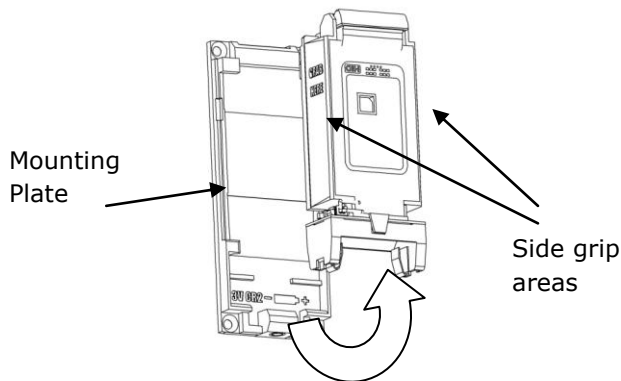

Pre-drill through the mounting plate at the four corners and insert wood screws.

Reattach electronic module by sliding the top under the mounting plate's raised edges and pressing down firmly until it clicks.

7. Test Reader

Reattach cover and insert screw with the included hex wrench.

Use a credential known to the access control system to confirm it will read as desired. A green LED indicates access is granted. Refer to the LED reference card for any other codes.

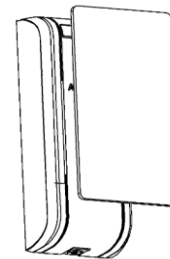
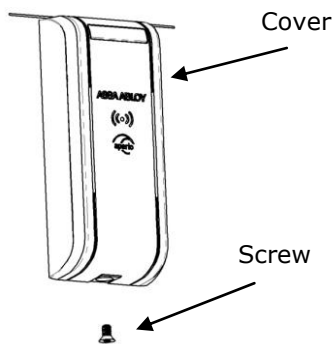

9. Optional: Attach Dress Cover

A separately purchased dress cover (R100-DCA) can be installed on the inside of a glass mounting surface. Peel the backing from the adhesive on the cover and affix to the window.

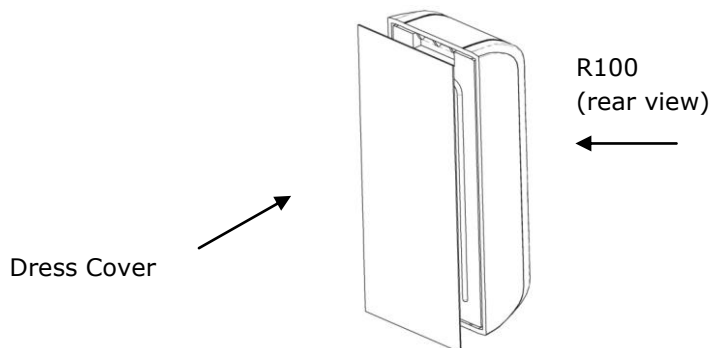

WARNING

FCC Statement

This equipment has been tested and found to comply with the limits for a class B digital device, pursuant to part 15 of the FCC Rules. These limits are designed to provide reasonable protection against harmful interference in a residential installation. This equipment generates, uses, and can radiate radio frequency energy and if not installed and used in accordance with the instructions, may cause harmful interference to radio communications. However, there is no guarantee that interference will not occur in a particular installation. If this equipment does cause harmful interference to radio or television reception, which can be determined by turning the equipment off and on, the user is encouraged to try to correct the interference by one or more of the following measures:

- Reorient or relocate the receiving antenna.
- Increase the separation between the equipment and receiver.
- Connect the equipment into an outlet on a circuit different from that to which the receiver is connected.
- Consult the dealer or an experienced radio/TV technician for help.

Operation with non-approved equipment is likely to result in interference to radio and TV reception. The user is cautioned that changes and modifications made to the equipment without the approval of manufacturer could void the user's authority to operate this equipment.

IC Statement

This device complies with Industry Canada license-exempt RSS standards(s).
Operation is subject to the following two conditions:

- (1) this device may not cause interference, and
- (2) this device must accept any interference, including interference that may cause undesired operation.

Conformité aux normes FCC

Cet équipement a été testé et trouvé conforme aux limites pour un dispositif numérique de classe B, conformément à la Partie 15 des règlements de la FCC. Ces limites sont conçues pour fournir une protection raisonnable contre les interférences nuisibles dans une installation résidentielle. Cet équipement génère, utilise et peut émettre des fréquences radio et, s'il n'est pas installé et utilisé conformément aux instructions du fabricant, peut causer des interférences nuisibles aux communications radio. Rien ne garantit cependant que l'interférence ne se produira pas dans une installation particulière. Si cet équipement provoque des interférences nuisibles à la réception radio ou de télévision, qui peut être déterminé en comparant et en l'éteignant, l'utilisateur est encouragé à essayer de corriger les interférence par une ou plusieurs des mesures suivantes:

- Réorienter ou déplacer l'antenne de réception.
- Augmenter la distance entre l'équipement et le récepteur.
- Branchez l'appareil dans une prise sur un circuit différent de celui auquel le récepteur est connecté.
- Consultez votre revendeur ou un technicien radio / TV pour assistance. Avertissement

Les changements ou modifications à cet appareil sans expressément approuvée par la partie responsable de conformité pourraient annuler l'autorité de l'utilisateur de faire fonctionner cet équipement.

Conformité aux normes IC

Cet appareil est conforme avec Industrie Canada exempt de licence RSS standard(s).
Son fonctionnement est soumise aux deux conditions suivantes:

- (1) cet appareil ne peut causer d'interférences, et
- (2) cet appareil doit accepter toute interférence, y compris des interférences qui peuvent provoquer un fonctionnement indésirable du périphérique.

For Technical Support please call 1-800-624-5625