

## Performance Features

- Fully adjustable from 1 - 6 allowing for maximum flexibility.
- Delayed action and backcheck are standard in the same door closer body.
- All-weather fluid ensures optimal operational performance in multiple climate conditions.

## Certifications



- ANSI/BHMA A156.4 Series – Grade 1
- ANSI A117.1 Accessibility Code (ADA Compliant)
- UL/cUL listed (3 hour) for self-closing doors without hold open
- UL10C Positive Pressure Rated
- UL10B Pressure Rated

## Product Specifications

- Handing – All QDC300 Series Closers are non-handed.
- Material – Cast aluminum closer body.
- All-weather fluid.
- Cover – Full, architectural plastic cover also available.
- Arms & brackets – Tri-pack standard (regular, top jamb, parallel configurations). Hold open and dead stop arms also available.
- Arm material – Heat-treated carbon steel.
- Springs – High-impact hand-drawn steel wires.
- Pinions – Heat-treated chrome molybdenum steel.
- Cylinder construction – Heat-treated free-cutting carbon steel.
- Fasteners – Wood and machine screws standard; sex nuts and self-tapping screws shipped standard.
- Door weights & sizes:

Size	Applicable Door Weight	Door Width Ranges	
		Interior	Exterior
1	33 – 55 LBS (15 – 30 Kg)	32" (0.81m)	28" (0.71m)
2	56 – 99 LBS (30 – 45 Kg)	36" (0.91m)	32" (0.81m)
3	99 – 143 LBS (45 – 65 Kg)	42" (1.07m)	36" (0.91m)
4	143 – 187 LBS (65 – 85 Kg)	48" (1.22m)	42" (1.07m)
5	187 – 264 LBS (85 – 120 Kg)	54" (1.37m)	48" (1.22m)
6	264 – 330 LBS (120 – 150 Kg)	58" (1.47m)	54" (1.32m)

## Warranty

- Lifetime Mechanical and 3-year finish



Tri-Pack Arm



Tri-Pack Arm with Hold-Open



Heavy Duty Arm with Compression Stop



Heavy Duty Arm with Hold-Open and Compression Stop

## Door Closer Functions

Series	Description
QDC311	Tri-Pack Arm
QDC312	Tri-Pack Arm with Hold-Open
QDC313	Heavy Duty Arm with Compression Stop
QDC314	Heavy Duty Arm with Hold-Open and Compression Stop

## Finishes

BHMA	Description
689	Painted Aluminum
690	Painted Dark Bronze
696	Painted Satin Brass



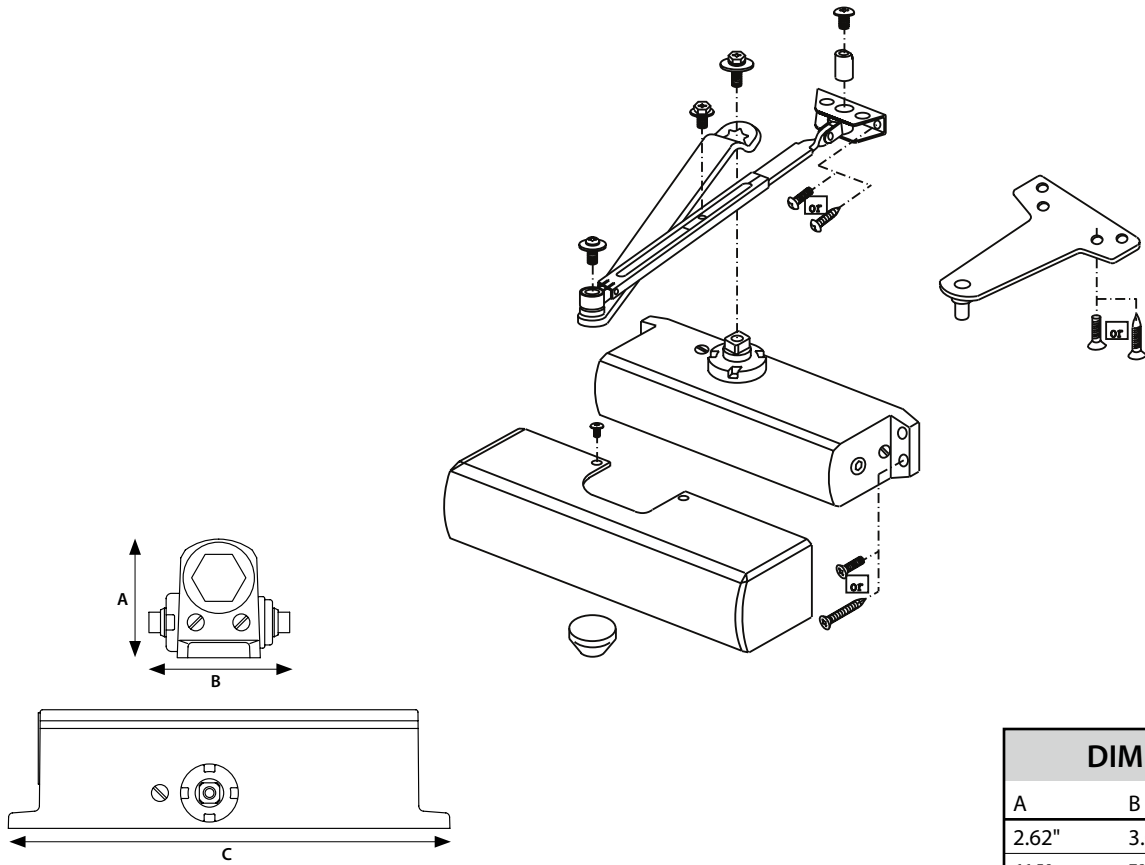

# DOOR CLOSERS

QDC  
300 Series Grade 1  
Standard-Duty Door Closers



DIMENSIONS		
A	B	C
2.62"	3.08"	9.80"
66.50mm	78.10mm	249mm

Model/Series	Functions	Qty
QDC311	Tri-Pack Arm	6
QDC312	Tri-Pack Arm with Hold-Open	6
QDC313	Heavy Duty Arm with Compression Stop	3
QDC314	Heavy Duty Arm with Hold-Open and Compression Stop	3

Order with Closer	Description	Service Part #
 <b>F</b>	Full-size cover (specify finish)	8Q00094
 <b>S</b>	Slim-line cover (specify finish)	8Q00096
	Sex nuts (Qty 4) (specify finish)	8Q00097
	Self-tapping screws (Qty 8) (specify finish)	8Q00436