

Performance Features

- Fully adjustable from 1 - 6 allowing for maximum flexibility.
- All-weather fluid ensures optimal operational performance in multiple climate conditions.
- Delayed action and backcheck are standard in the same door closer body.

Certifications



- ANSI/BHMA A156.4 Series – Grade 1
- ANSI A117.1 Accessibility Code (ADA Compliant)
- UL/cUL listed (3 hour) for self closing
- UL10C Positive Pressure Rated
- UL10B Pressure Rated

Product Specifications

- Handing – All QDC100 Series Closers are non-handed (QDC116 arms & metal covers are handed).
- Cast-iron closer body.
- All-weather fluid.
- Stacked valves prevent oil leaks from screws being backed out too far.
- Cover – metal and plastic covers available.
- Arms & brackets – Tri-pack standard, additional arms optional.
- Arm material – Heat-treated carbon steel.
- Springs – High-impact hand-drawn steel wires.
- Pinions – Heat-treated chrome molybdenum steel.
- Cylinder construction – Heat-treated free-cutting carbon steel.
- Fasteners – Wood and machine screws standard; sex nuts and self-reaming, self-tapping screws shipped standard.
- Door weights & sizes:

Size	Applicable Door Weight	Door Width Ranges	
		Interior	Exterior
1	33 – 55 LBS (15 – 30 Kg)	32" (0.81m)	28" (0.71m)
2	56 – 99 LBS (30 – 45 Kg)	36" (0.91m)	32" (0.81m)
3	99 – 143 LBS (45 – 65 Kg)	42" (1.07m)	36" (0.91m)
4	143 – 187 LBS (65 – 85 Kg)	48" (1.22m)	42" (1.07m)
5	187 – 264 LBS (85 – 120 Kg)	54" (1.37m)	48" (1.22m)
6*	264 – 330 LBS (120 – 150 Kg)	58" (1.47m)	54" (1.32m)

*50% spring power adjustment over size 6.

Warranty

- Lifetime Mechanical and 3-year finish

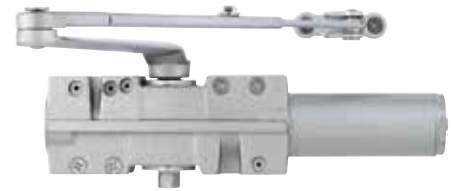

QDC111



Rounded Plastic Cover (R)
(Ships Standard)



Metal Cover (M)
(Left hand shown)

Door Closer Functions

Series	Description
QDC111	Tri-Pack Arm
QDC112	Tri-Pack Arm with Hold-Open
QDC113	Extra Duty Arm with Compression Stop
QDC114	Extra Duty Arm with Hold-Open and Compression Stop
QDC115	Extra Duty Arm
QDC116	Extra Duty Arm with Hold-Open (handed)
QDC117	Extra Duty Arm with Stop
QDC118	Extra Duty Arm with Hold-Open and Stop
QDC119	Extra Duty Arm with Spring Stop
QDC120	Extra Duty Arm with Hold Open and Spring Stop

Finishes

BHMA	Description
689	Painted Aluminum
690	Painted Dark Bronze
696	Painted Satin Brass

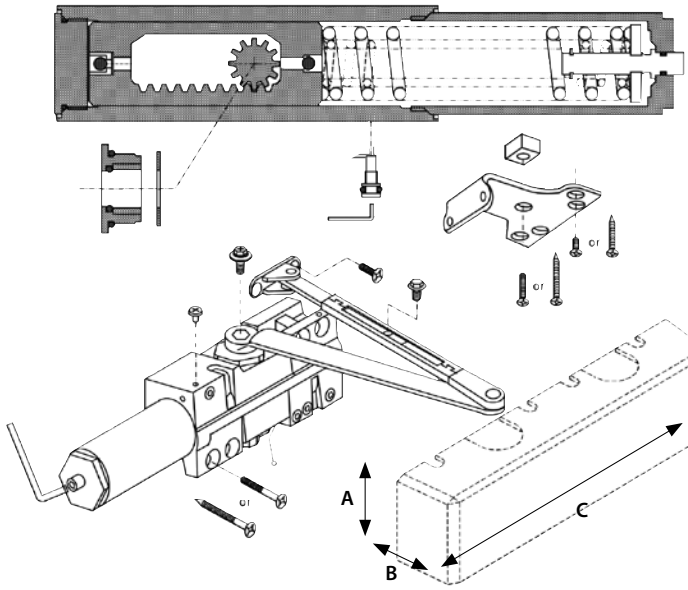

DOOR CLOSERS

QDC
100 Series Grade 1
Extra Heavy-Duty Door Closers



DIMENSIONS		
A	B	C
3.50"	2.25"	12.1875"
88.90mm	57.15mm	309.56mm

Model/ Series	Functions	Case Qty
QDC111	Tri-Pack Arm	3
QDC112	Tri-Pack Arm with Hold-Open	1
QDC113	Extra Duty Arm with Compression Stop	1
QDC114	Extra Duty Arm with Hold-Open and Compression Stop	1
QDC115	Extra Duty Arm	1
QDC116	Extra Duty Arm with Hold-Open (handed)	1
QDC117	Extra Duty Arm with Stop	1
QDC118	Extra Duty Arm with Hold-Open and Stop	1
QDC119	Extra Duty Arm with Spring Stop	1
QDC120	Extra Duty Arm with Hold Open and Spring Stop	1

Order with Closer	Description	Service Part #
	Sex nuts (Qty 4) (specify finish)	8Q00097
	Self-reaming, self-tapping screws (specify finish)	8Q00547
M	QDC100 Series Metal Cover - RH	8Q01140
M	QDC100 Series Metal Cover - LH	8Q01141