



## INSTALLATION INSTRUCTIONS

ARROW N42, N41, N43, N44,  
N40 DEADLOCKS

CHECK LOCKSET FOR CORRECT BEVEL. TO CHANGE, LOOSEN SCREWS (FASTENING FRONT TO CASE), ROTATE FRONT TO PROPER BEVEL AND RE-TIGHTEN.

### 1 MORTISE FOR LOCK CASE AND FRONT AT CENTERLINE OF DOOR EDGE.

NOTE: MORTISE DOOR SO THAT LATCH CASE IS CENTERED IN DOOR

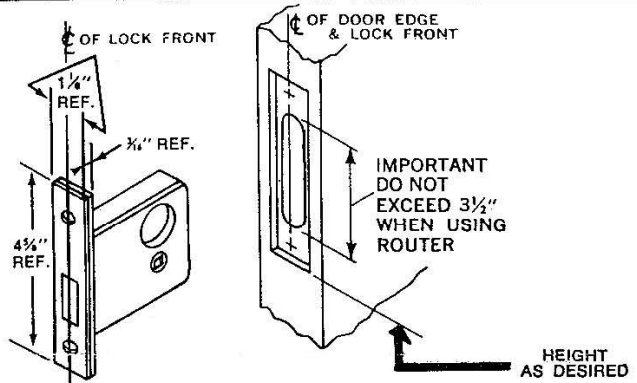
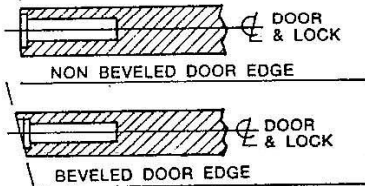

### 2 BORE REQUIRED HOLES FOR CYLINDER AND TURN KNOB AS INDICATED IN CHART.

CHECK BOX LABEL FOR FUNCTION NUMBER BEFORE CUTTING HOLES IN DOOR

LOCK	HOLE NOS.
N42	1 AND 2
N41	1 AND 3
N43	1
N44	1 AND 3
N40	3

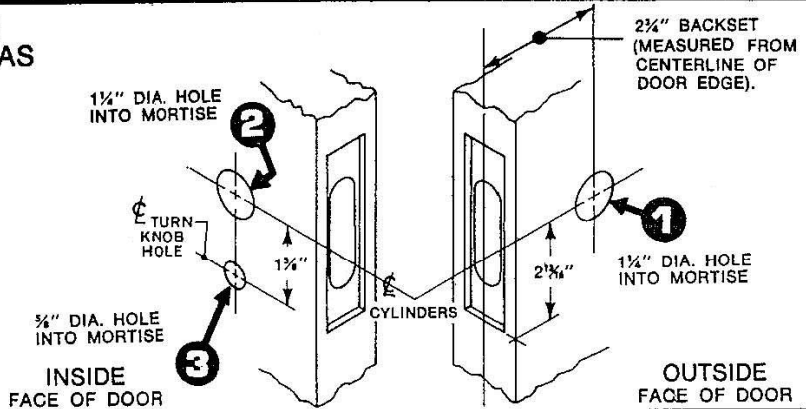

- 3 A. REMOVE OUTSIDE FRONT AND MOUNT LOCK.
- B. PLACE CYLINDER THRU CYLINDER RING AND SCREW INTO LOCK (THREE COMPLETE TURNS FOR DOUBLE CYLINDER FUNCTIONS; FOUR FOR SINGLE CYLINDERS). ADJUST IN OR OUT ONE TURN IF NECESSARY TO OBTAIN BEST OPERATION. FASTEN CYLINDER (WITH KEYHOLE FACING DOWN) BY TIGHTENING APPROPRIATE CLAMPING SCREW.
- C. REPLACE OUTSIDE FRONT.
- D. APPLY TURN KNOB (IF USED)

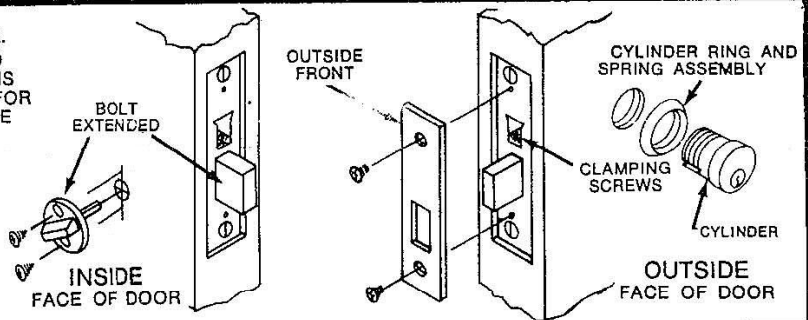

### 4 MORTISE JAMB FOR STRIKE.

