



23761

Model 7902/ES7902



Control Box

Installation Instructions

For closer information see closer installation instruction sheet.

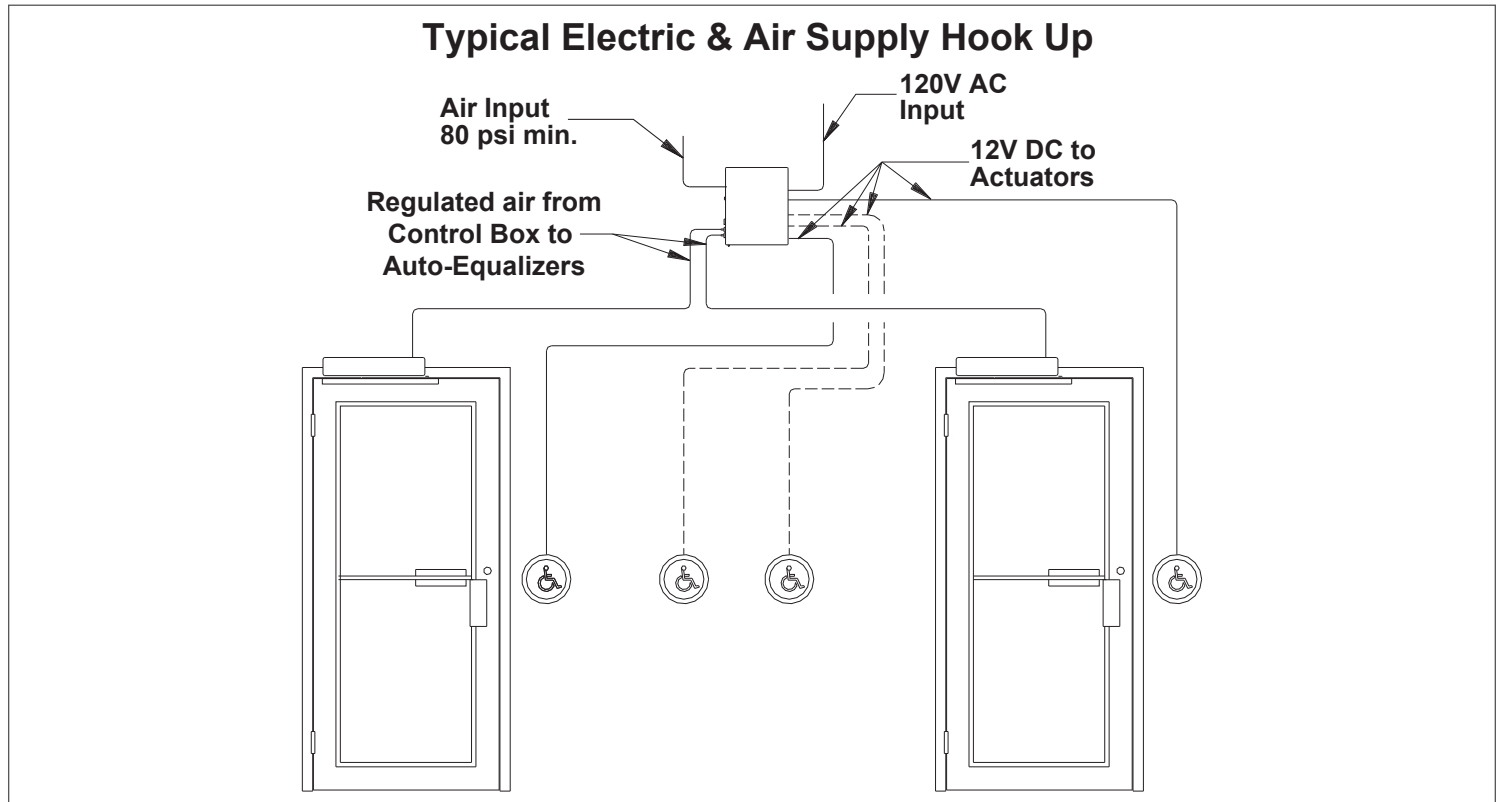

Installation

- | | |
|---|--|
| <p>1a Locate box on interior of building within 100 tubing feet of the door to be controlled. Box must be in a clean, dry, well ventilated place where temperatures do not exceed 120°F or fall below 35°F.</p> | <p>1f Turn on power. Air valve will operate one cycle when power is applied.</p> |
| <p>1b Mount box to a structurally sound surface using screws provided as shown on page 2 with air fittings on left side as shown. Do not mount box upside down or on a horizontal plane.</p> | <p>1g Air pressure output has been preset at factory. If more air pressure is required to adequately open doors, adjust regulator valves found inside control box.</p> |
| <p>1c Refer to instructions packed with actuators and connect leads to terminals 6, 8, 9, and 10 as required.</p> | <p>1h Adjust time delay to keep air valve energized by turning adjustment wheel on timer modules "A" & "B" (CW to increase - CCW to decrease). The LED (light) on the timer module indicates the valve is energized. The time can be adjusted from 0-30 seconds. 10 seconds is a "normal" delay.</p> |
| <p>1d Connect 1/8 inch diameter air tubing from clean, dry air source to inlet on side of box. Connect 1/8 inch diameter air tubing from door control to output fittings "A" & "B" on side of the control box.</p> | <p>1i Test actuators to insure wiring and tubing are properly connected.</p> |
| <p>1e Connect unpowered 120V AC input to terminals 3, 4, and ground screw. (Line side to terminal 3, neutral side to terminal 4 and ground wire to ground screw.) If door control is on a fire door, 120V AC input must be interrupted by the fire alarm panel when in alarm. When dry auxiliary fire alarm contacts are used, remove shunt from terminals 1 and 2 and connect to dry contacts of fire detector or alarm panel. Terminals 1 and 2 are in series with line side of 120V input.</p> | |

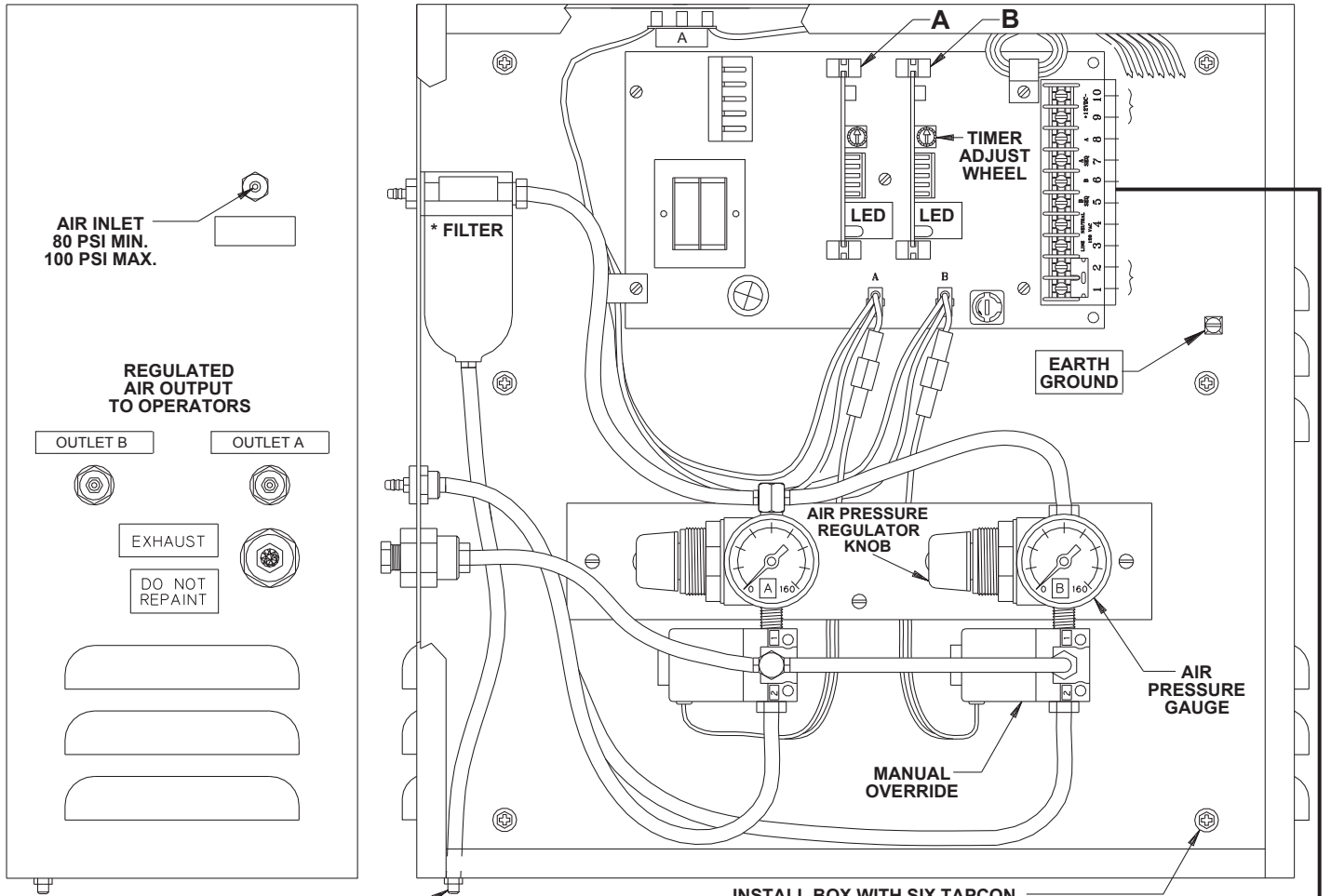

INSTALL BOX WITH SIX TAPCON CONCRETE SCREWS - 3/16 x 1 1/4 DRILL 5/32 HOLE 1 1/4" DEEP WITH CARBIDE TIPPED CONCRETE BIT

Electrical Data

Input = 120V AC @ .3 amps
 Power consumption 36 watts
 Output is 12V DC

CAUTION

Do not mount box upside down or in horizontal position. Locate where temperatures do not exceed 120°F or fall below 35°F.

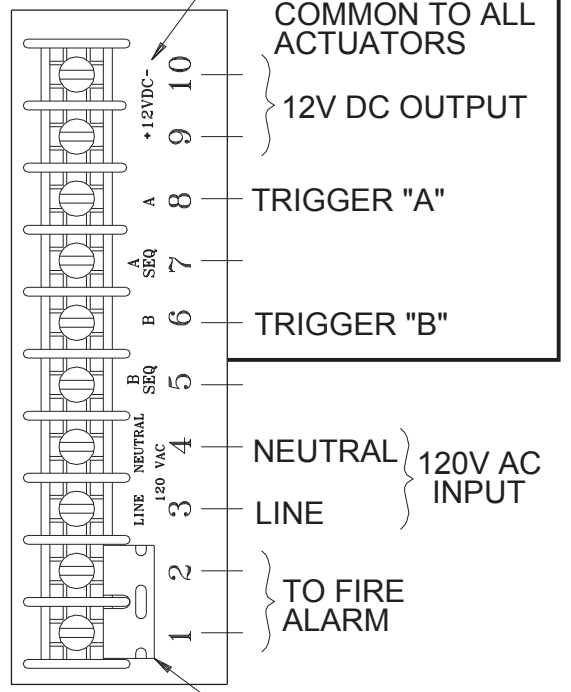

SHUNT
 * REMOVE THIS SHUNT ONLY WHEN CONNECTING TO NORMALLY CLOSED FIRE ALARMS CONTACTS

WARNING

HAZARDOUS VOLTAGE CAN SHOCK AND CAUSE SEVERE INJURY
 Disconnect power before making any electrical connections or performing maintenance.

AIR FILTER MAINTENANCE:

- EACH TIME BOWL IS CLEANED OR FILTER ELEMENT REPLACED:**
 - Depressurize unit
 - Inspect seals and replace cracked, deteriorated or damaged seals with original manufacturers approved seals only.
- FILTER ELEMENT** - Clean periodically by removing filter, tapping on hard surface and blowing off with compressed air. When servicing element, blow off louvers with compressed air.
- AUTOMATIC DRAIN** - If automatic drain fails to keep filter bowl drained of water, use a pencil or small screwdriver to push the piston up, allowing filter to drain.
- Be sure filter bowl assembly is firmly secured in place before reactivating unit.
- Replace filter with LCN part #929.

! DANGER CONTROL BOX MUST BE CONNECTED TO EARTH GROUND

Installation Troubleshooting Chart

Symptom	Possible Cause	Suggested Remedy
No Power Opening	No power to control box / blown fuse	Verify 120VAC 60HZ power is present at terminals 3 & 4 on control box terminal strip. Check fuse. Replace only with 5 amp (3AG type) fuse.
	Actuator(s) not connected properly	Be sure a timer module board is firmly in place in "A" & "B" slots. Operate actuator(s). LED on timer module should light when actuator is used. If not, briefly short actuator terminals 6 & 10 and 8 & 10 in the control box. If LED lights, check wiring to actuators for an open circuit. If it does not light, check for voltage at terminals 9 & 10. Voltage should read from 11.75 to 13.25V DC. If there is no reading, disconnect leads from terminals 9 & 10. Short actuator terminals 6 & 10 and 8 & 10. If LED lights, check for short circuit in actuators.
	Fire alarm system causing open circuit on terminals 1 & 2	Shunt terminals 1 & 2 with power off. Restore power. If control operates when actuator terminals 8 & 10 in the control box are shorted, an open circuit exist in wiring to fire alarm. When Auto-Equalizer is not used with fire alarms, terminals 1 & 2 must be permanently shorted with a shunt. IMPORTANT! When Auto-Equalizer is connected to fire alarm, make sure shunt is removed from terminals 1 & 2. Terminals 1 & 2 are one leg of 120V line.
	No input to Auto-Equalizer operator	Disconnect tubing from Auto-Equalizer operator. Try actuator and verify that air is coming out of tubing. If not, trace tubing to control box, checking for breaks or kinks in air line.
	Air lines obstructed with dirt or ice.	Clean or thaw lines and reroute if necessary. Eliminate dips near cold zones. If freezing is a repeated problem, desiccant filter may need to be changed.
	Air valves not working	Make sure air valve leads are plugged into main board. (Be sure valves in system are plugged into connector "A" & "B".)
	Low or no air inlet pressure to control box.	Check compressor output to make sure air shut-off is open. 80 psi must be available at the control box. If not, check compressor and lines.
	No air output to Auto-Equalizer operator	Check pressure gauge in control box. Adjust as required, if necessary. Check for leaking or damaged lines in control box.
Power Opening will not time out.	Scanner maintaining signal to control box.	Make sure lenses are clean and there are no obstructions in front of scanner. Model 909 or 939 proximity scanner may "see" an opposite wall. Adjust range as described earlier.
	Switch circuit maintaining contact.	Check for short circuit or error in wiring to actuator.
	Air valve blocked open with contaminant.	Cycle valve several times by momentarily shorting terminals 6 & 10 and 8 & 10. This should clear valve.
	Control box exhaust restricted	Exhaust muffler may be clogged. Clean in alcohol or mineral spirits.

Model ES7902 For Use With Electric Latching Hardware

ES7902 - 2 electric strikes maximum

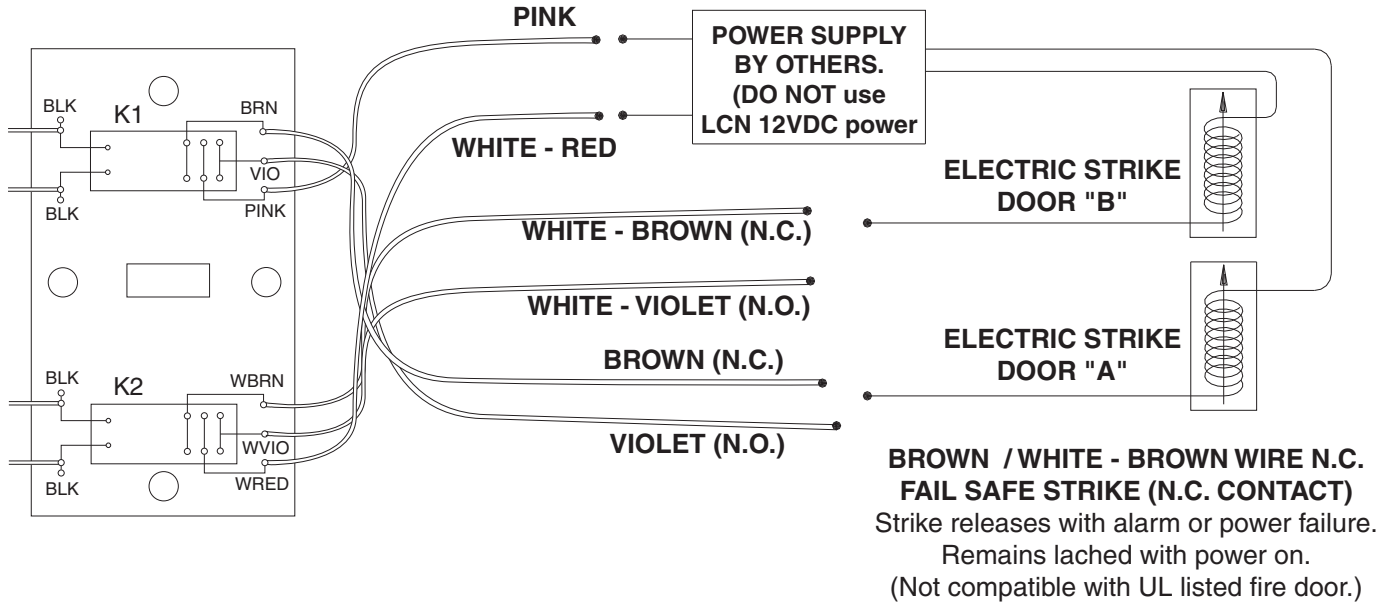

**VIOLET / WHITE - VIOLET WIRE N.O.
FAIL SECURE STRIKE (N.O. CONTACT)**

Strike releases when energized. Remains locked in alarm or power failure. (Manual release hardware required to open door in alarm or power failure.)

**BROWN / WHITE - BROWN WIRE N.C.
FAIL SAFE STRIKE (N.C. CONTACT)**
Strike releases with alarm or power failure.
Remains latched with power on.
(Not compatible with UL listed fire door.)

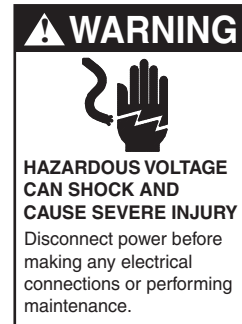

Customer Service

1-877-671-7011 www.allegion.com/us



© Allegion 2014
Printed in U.S.A.
23761 Rev. 01/14-d

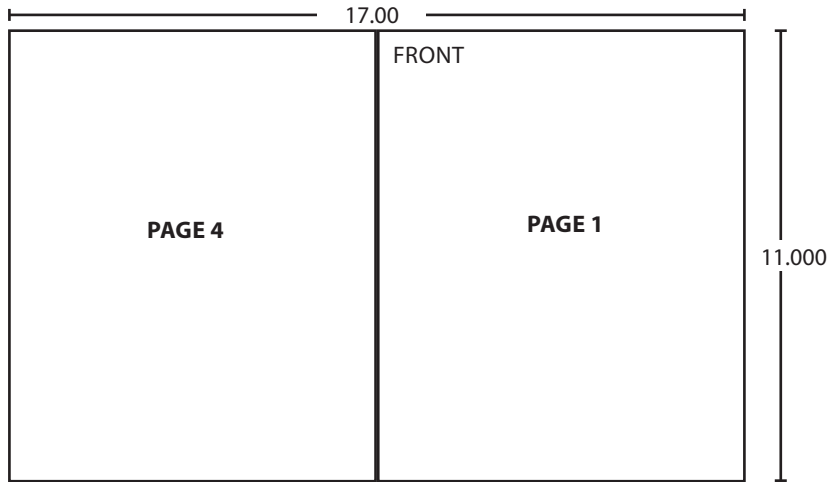

BEGINNING SHEET

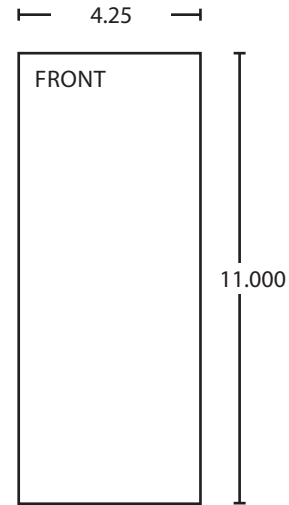
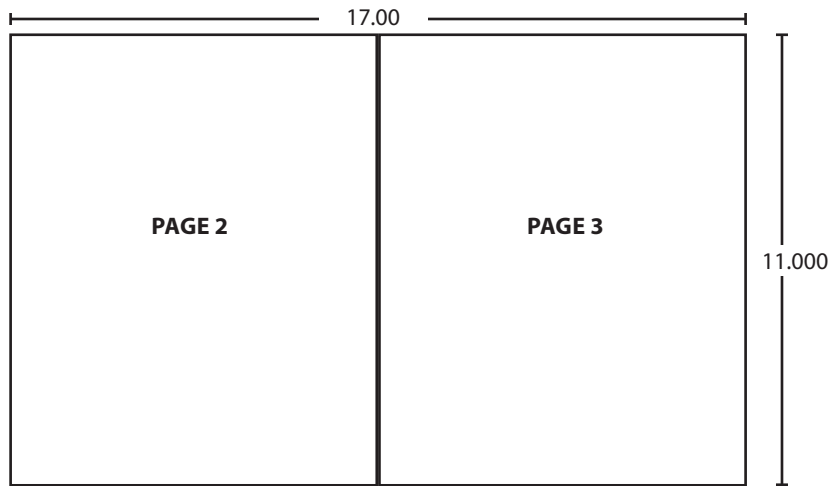

FOLDED SHEET

Additional Notes:
1. None

Revision History						Revision Description: D > Revised artwork				
D	E	F	G	H	J					
043228										
Material White Paper						Edited By	Approved By	EC Number	Release Date	
						D. Myers	M. Sasso	043228	01-01-14	
Notes 1. printed two sides 2. printed black 3. tolerance ± .13 4. printed in country may vary 5. drawings not to scale						Title 7902/ES7902 Series Control Box Instruction Sheet				
						Creation Date 04-27-10	Number 23761		Revision D	
						Created By N/A	Activity 3899 Hancock Expwy Security, CO 80911			
						Software: InDesign CS6		© Allegion 2014		