



25381

# 4840 Auto-Equalizer

# LCN®

Non-Handed/Non-Sized/Low Energy  
Installation And Adjustment Of Door Operator

Installation Instructions

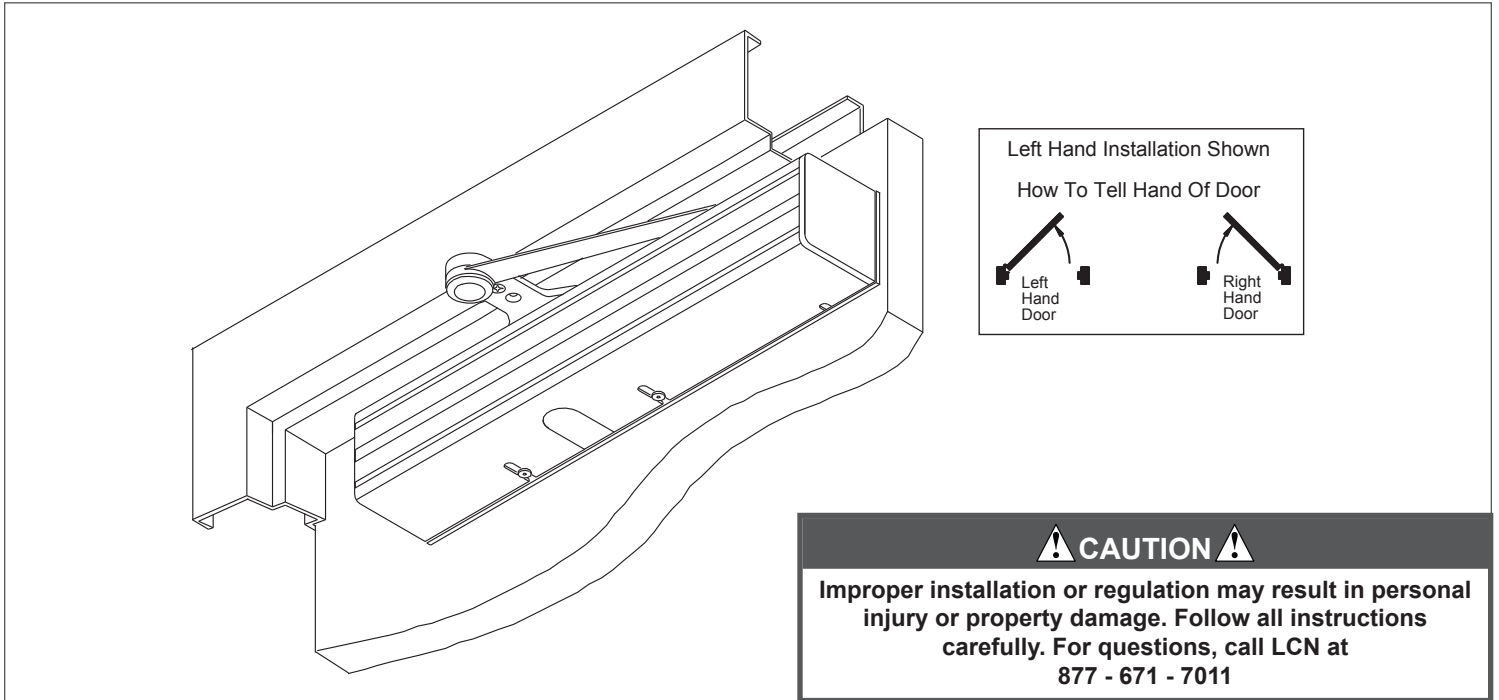

## 1 General Information

This door operator requires these additional system components:

7900 or 7980 series Control Box

- 459 Pnuematic Door Loop Kit, (4 1/2 " maximum reveal depth, see page 6) or
- 460 Pnuematic Transfer Hinge Kit (see page 6)

Push & Pull side actuator devices (switches)

① **NOTE: 460 Transfer Hinge requires an interior door raceway between transfer hinge and 4840 Auto - Equalizer®**

### Requirements:

Minimum door width is 24"

Minimum door top rail is 4 1/2"

Minimum stop width is 1"

Flush or single rabbeted frames require a - 418 FPA

### Arm Options:

EDA (standard), Cush N Stop or Spring Cush

**Figure 1**

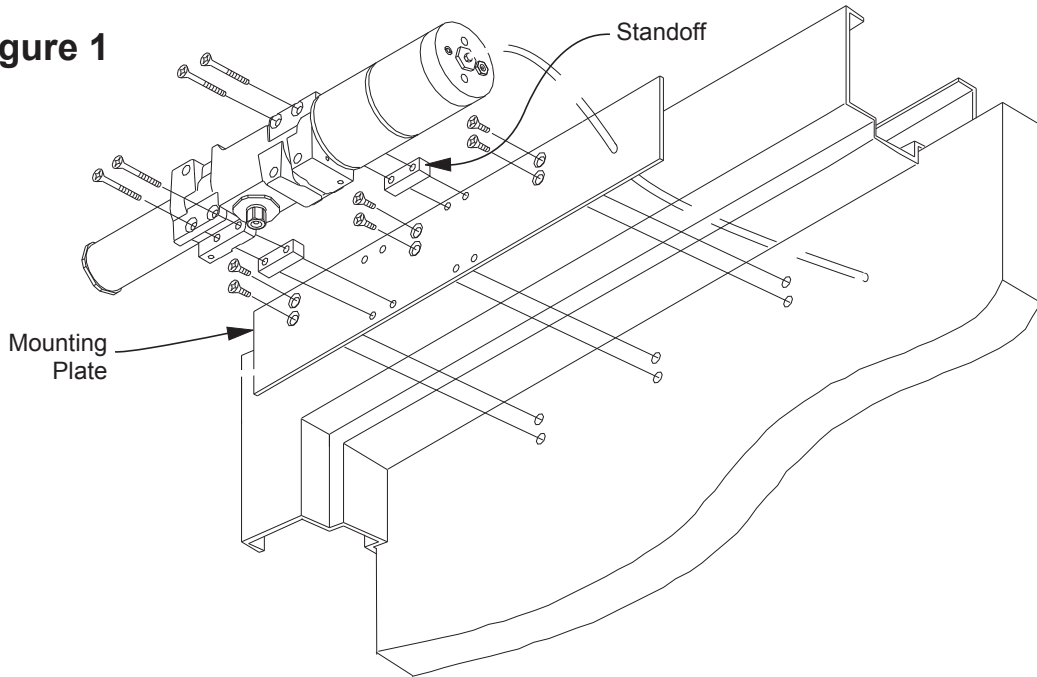

## 2 Operator Installation

① **NOTE:** If using the 460 transfer hinge, install at this time. See page 6 for details.

2a Prepare door & frame per template on page 7. Drill and/or tap holes to receive 1/4 - 20 machine screws or No. 14 wood screws. Use fasteners provided by LCN to keep warranty valid.

2b Remove operator assembly from mounting plate, as shown in **Figure 1** above. Install mounting plate on door using (6) 1/4 - 20 x 5/8" machine screws or (6) No. 14 x 1 1/2" wood screws provided. Reattach operator assembly.

2c Place arm on the top of closer shaft with main arm parallel to the door. Place wrench on the bottom of the closer shaft and rotate toward hinge approx. 30°. See **Figure 2**. Main arm can now be placed on to closer shaft. Secure with arm screw.

① **NOTE:** If installed properly, main arm will rest against door.

2d Swing door open about 45°. Using the fasteners provided, mount shoe to frame stop per proper templating on page 7. Be sure to install the "fifth" screw. If stop is not wide enough, use spacer block provided or cush shoe support shown on page 7.

2e Connect air line to air inlet fitting, then feed other end toward control box by either using the 15" pneumatic door loop or the pneumatic transfer hinge (see page 6).

**Figure 2**

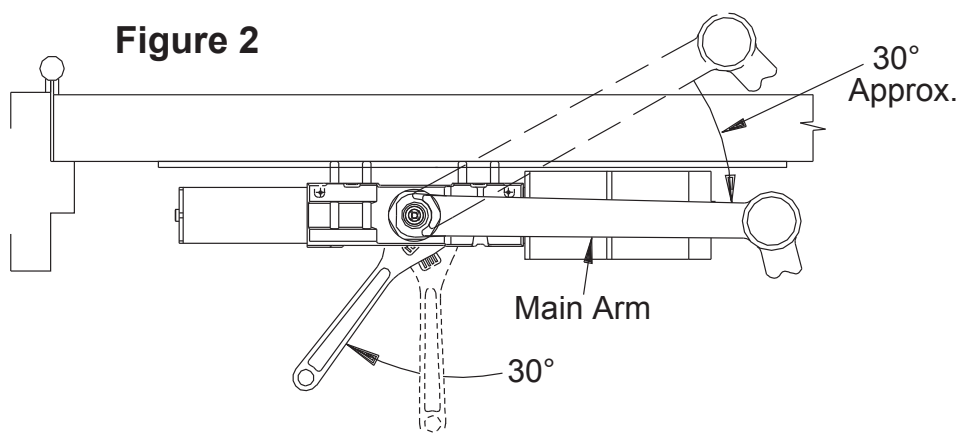

### 3 Closing Force Adjustment (see Figure 3)

3a To adjust **Closing Force**, turn the spring adjustment nut clockwise or counter-clockwise the required number of turns to match the door width in **Tables 1 & 2**. Maximum adjustment, 5 turns counterclockwise and 7 turns clockwise.



**Do not set door speed faster than chart recommends.**

### 4 Closing Speed Adjustment (See Figure 3)

4a **THE 4840 SERIES CLOSER HAS BEEN REGULATED PRIOR TO SHIPMENT.** If regulation adjustments are needed use 3/32 Hex wrench furnished, and refer below.

4b A “normal” closing time from 90° open position is 5 to 7 seconds, evenly divided between **Main Speed** and **Latch Speed**.

4c To slow **Main Speed** of door, turn regulating screw (nearest to arm) clockwise.

4d To slow **Latch Speed** of door, turn regulating screw (nearest to latch) clockwise.

4e Do not allow door to slam into frame.

### 5 Backcheck Adjustment

5a Backcheck slows the door swing as it approaches full opening (see Figure 3).

5b Increase the resistance of backcheck only if necessary to prevent the door from striking a wall. To do this, turn the regulating screw (nearest to hinge) clockwise by quarter turns. **DO NOT USE AN ABRUPT BACKCHECK.**

Table 1

Exterior Door	
Maximum Door Width	Number of Turns
30"	0 Turns
36"	2 Turns C.W.
42"	7 Turns C.W.

Table 2

Interior Door	
Maximum Door Width	Number of Turns
34"	5 Turns C.C.W.
38"	0 Turns
48"	2 Turns C.W.
54"	7 Turns C.W.

FIGURE 3

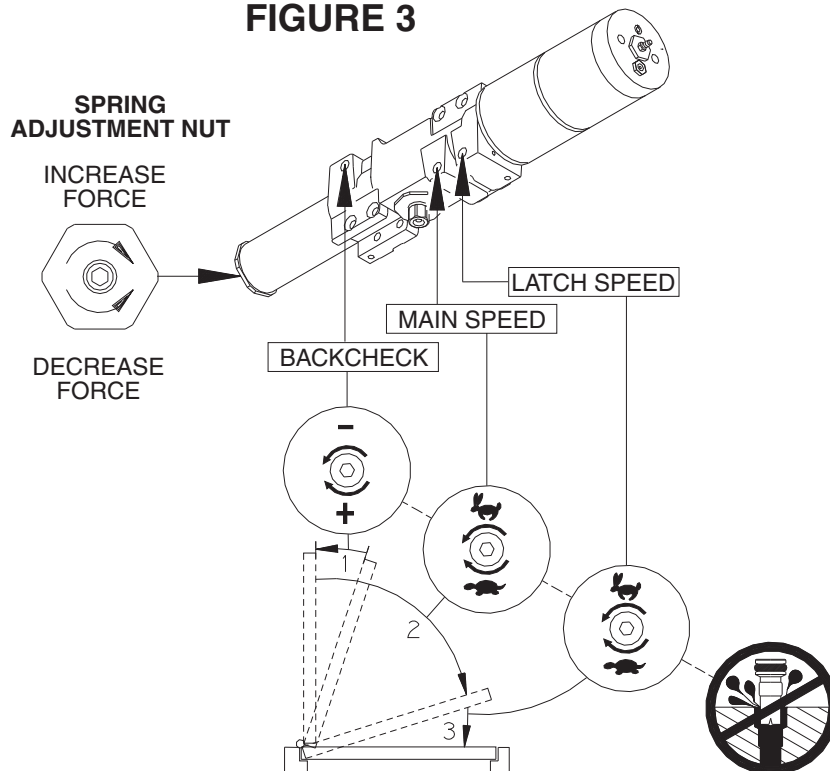

## 6 Opening Speed Adjustment

① **NOTE:** For air pressure regulation, see control box instructions.

- 6a The door opening speed must be adjusted to suit the width and weight of door. The wider and / or heavier the door, the slower it should open. To determine opening speed, measure door width and weight and set speed to open door from 0° to 80° for the time shown in **Table 3** below. The opening speed control adjusting screw is located in the end of the door operator near the tubing connection (see **Figure 4**). Using a 3/32" hex wrench (provided), turn the speed control clockwise to slow the door, counterclockwise to increase door speed.

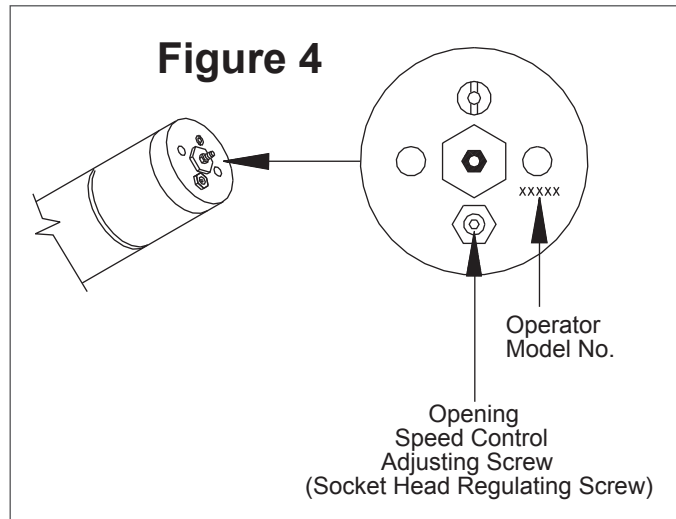

Table 3

Door Weight in Pounds	Fastest Opening Time in Seconds to 80° Position		
	Door Width in Inches		
	36"	42"	48"
100 lbs.	3.0 sec.	3.0 sec.	3.0 sec.
125 lbs.	3.5 sec.	3.5 sec.	3.5 sec.
150 lbs.	3.5 sec.	3.5 sec.	3.5 sec.
200 lbs.	4.0 sec.	4.0 sec.	4.0 sec.

① **NOTE:** If door width or weight is between the sizes and pounds listed, use the time shown for the next wider or heavier door.

- 6b If door weight cannot be measured, the weight can be estimated by finding the area of the door (length x width) and multiplying it by the weight per square foot for the door type that is being used, as shown in **Table 4** below.

Table 4

Door Type	Weight per Sq. Ft.
Solid Core Wood	5.5
20 Ga. Flush Hollow Metal	
Aluminum x 1" Glass	
Mineral Core Door	7.0
16 Ga. Flush Hollow Metal	
Aluminum x 1" Glass	

## 7 Delay Time Adjustment

After opening, the door should remain at the 90° position for no less than 5 seconds. This “Delay Time” can be increased to approximately 30 seconds by turning the timer adjustment wheel(s) clockwise. For the location of this wheel(s), refer to 7900 or 7980 Series Control Box Instruction Sheet. Adjust “Delay Time” to maximum practical for the elderly or handicapped. Time cycle begins when switch or scanner is activated.

## 8 Attach Cover

8a Slide cover insert into the bottom cutout in cover (**see Figure 5**).

8b Push cover over the operator assembly and against mounting plate.

8c Insert cover screws and tighten securely.

## 9 Locating the Caution/Automatic Door Decal

9a Locate one decal on each side of door near lock stile of door, approximately 18” min. to 42” max. above the floor. The decal location must be visible without interference from door trim, panic devices, etc.

9b Clean a 6” x 6” area where decals will be placed.

9c Apply one decal (**item 16 on page 10**) on each side of the door. Remove backing and “roll” onto door to avoid trapping air under decal.

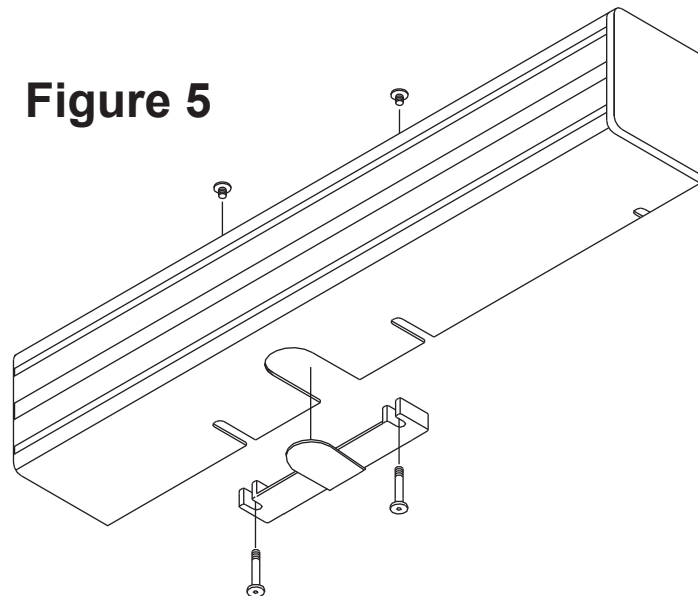

## Concealed or Surface Air Transfer Options

### 10 Pneumatic Door Loop Installation (see Figure 6)

① See page 8 for template

① Reveal must be less than 4 1/2"

10a Remove the cover end cap (closest to hinge stile of door) by removing the (2) Phillips head screws from inside the cover.

10b Place the proper hand template (see cutouts on page 11) over the end cap and tape down securely.

10c Once the template is in place, drill (1) 3/8" hole, and (2) 1/16" holes in the proper location.

10d After holes are drilled, remove template and place end cap back on the cover.

10e Feed 1/4" tubing through the drilled end cap and also through the 15" aluminum tubing supplied with kit.

10f Place 90° door loop cap on cover end cap (making sure to line up slots over the ends of the 15" tubing) and secure with No.6-32 screws provided.

10g Feed the 1/4" tubing (either 180° up the frame, or 90° into the frame), place the concealed 90° or the surface 180° (depending on the installation) door loop cap over end of the 15" aluminum tubing and secure to the frame of the door. (See Figure 6).

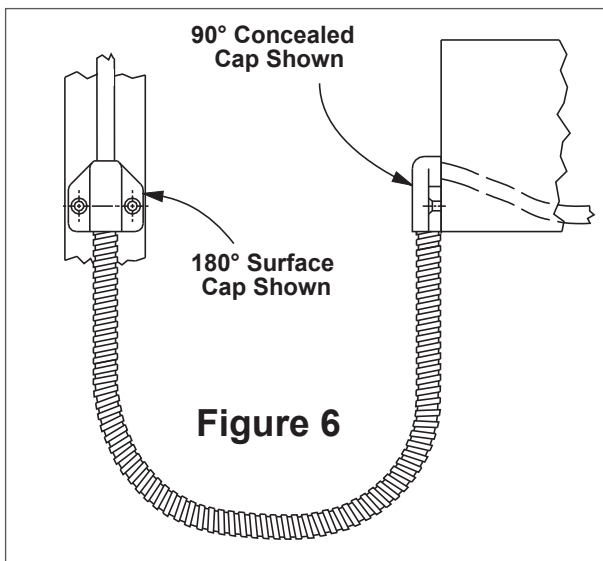

### 11 Pneumatic Transfer Hinge Installation (see Figure 7)

① A INTERIOR RACEWAY FROM TRANSFER HINGE TO 4840 CLOSER IS REQUIRED TO USE THIS PRODUCT, SEE PAGE 9 FOR TEMPLATE.

11a Apply pneumatic transfer hinge housing using No. 8-32 machine screws provided.

11b Connect tubing using the inline tubing splice provided

11c Apply transfer hinge unit using No.10-24 machine screws provided.

11d Check operation of pneumatic transfer hinge unit.

① NOT FOR USE WITH SWING CLEAR HINGES OR CENTER PIVOTS!

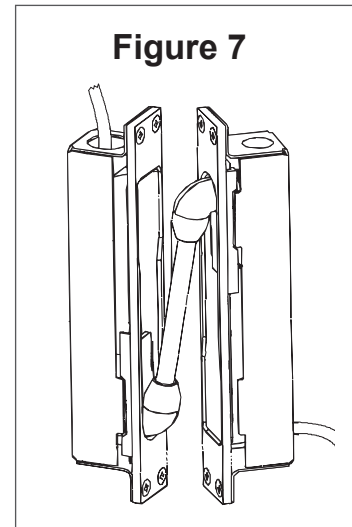

4840 AUTO-EQUALIZER

POWER OPENING 90°  
 CUSH MAX. OPENING 100°  
 SPRING CUSH MAX. OPENING 105°  
 EDA MAX. OPENING 105°

- (4)  $\frac{1}{4}$  -20 x  $\frac{5}{8}$  P.H.M.S.
- (1)  $\frac{1}{4}$  -20 x  $1\frac{1}{2}$  P.H.M.S.  
OR
- (5) No. 14 x 2" P.H.W.S.

- GENERAL NOTES-
1. CONCEALED OR SURFACE AIR TRANSFER BY OTHERS REQUIRED.
  2. REINFORCING PER ANSI/SDI-100 RECOMMENDED FOR HOLLOW METAL DOORS AND FRAMES.
  3. HOLD OPEN SPRING CUSH ARM NOT AVAILABLE.
  4. CLOSER SIZE 20" x 3 1/2" x 3 5/16".
  5. PRINT ON PLATE WILL BE UPSIDE DOWN IN THIS INSTALLATION.

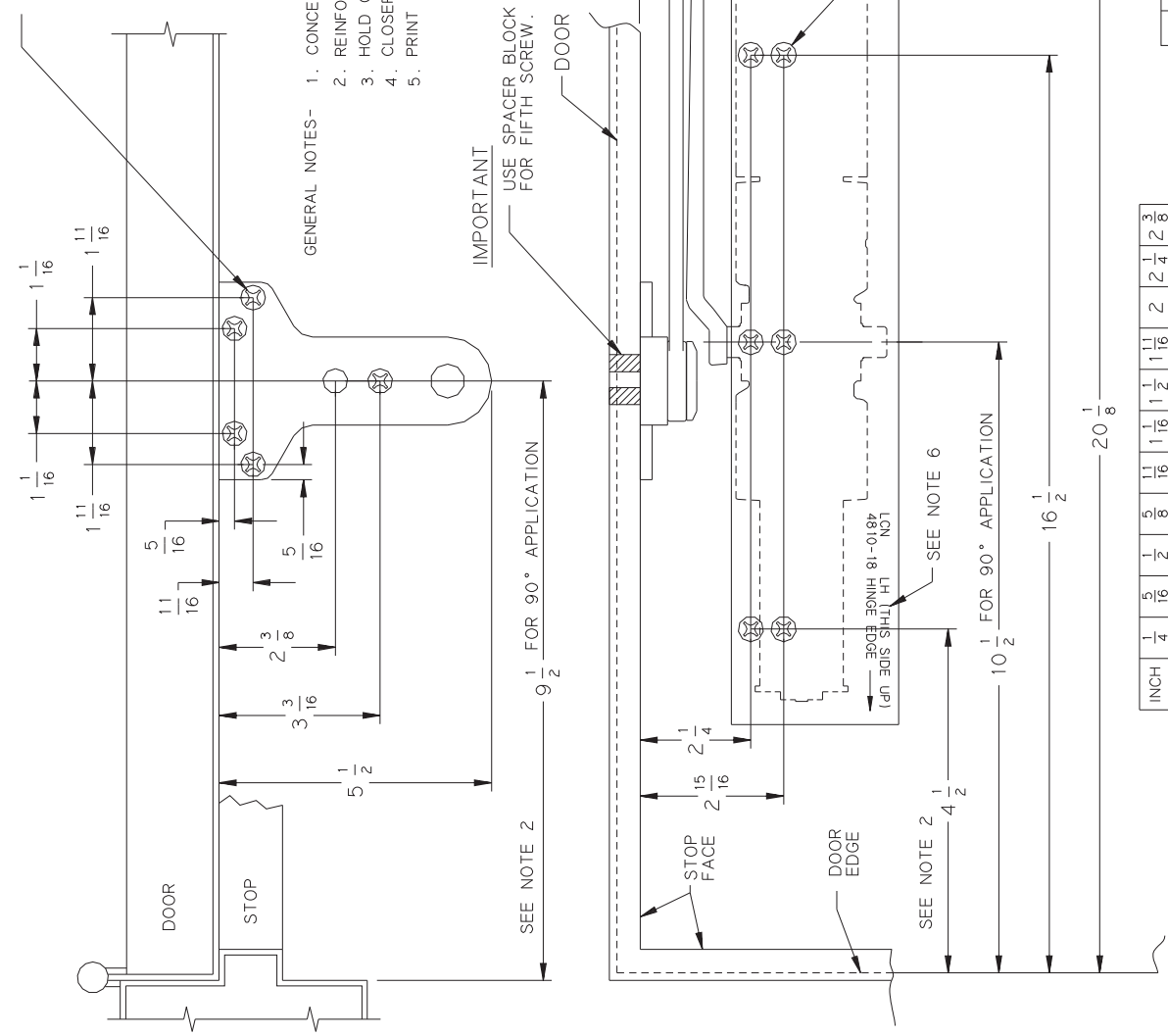

LEFT HAND SHOWN, RIGHT HAND OPPOSITE

INCH	1/4	5/16	3/8	1/2	5/8	11/16	1 1/16	1 1/2	2	2 1/4	2 3/8
M.M.	6	8	13	16	17	27	38	43	51	57	60
INCH	2 15/16	3 3/16	3 1/2	4 1/2	5 1/2	9 1/2	10 1/2	16 1/2	20	20 1/8	
M.M.	75	81	84	89	114	140	241	267	419	508	511

No.	REVISION	BY	DATE
0	RELEASE NEW DRAWING	JEJ	7/1/95
1	FIXED DIMENSION	AMM	06/06

APP BY JEJ 7/95  
 DO NOT SCALE  
**LCN®**  
 PUSH SIDE MOUNTED AUTO-EQUALIZER®  
 WITH 4040 EDA, CUSH, OR SPR. CUSH ARM

4840

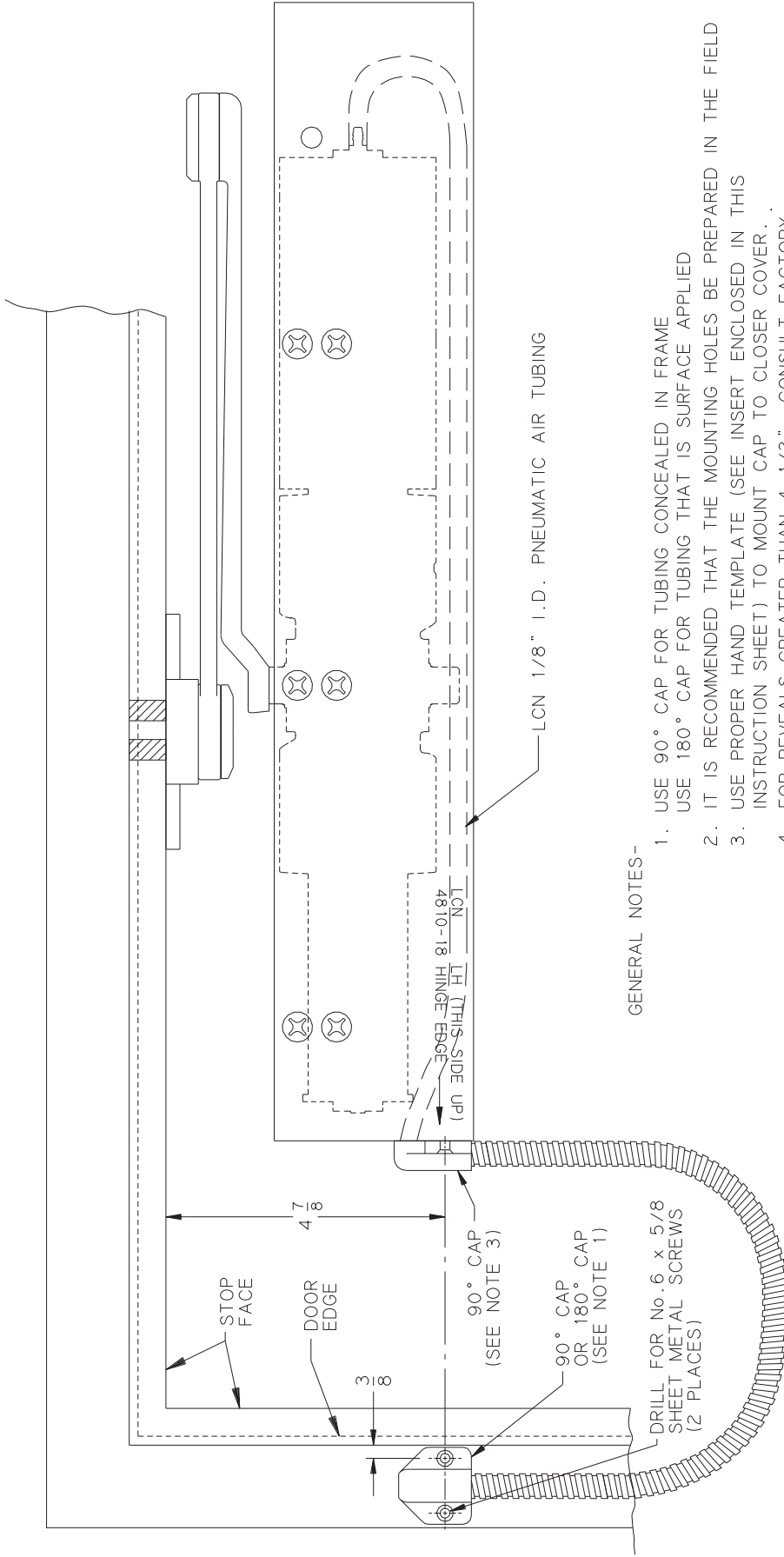

GENERAL NOTES-

1. USE 90° CAP FOR TUBING CONCEALED IN FRAME  
USE 180° CAP FOR TUBING THAT IS SURFACE APPLIED
2. IT IS RECOMMENDED THAT THE MOUNTING HOLES BE PREPARED IN THE FIELD
3. USE PROPER HAND TEMPLATE (SEE INSERT ENCLOSED IN THIS INSTRUCTION SHEET) TO MOUNT CAP TO CLOSER COVER.
4. FOR REVEALS GREATER THAN 4 1/2", CONSULT FACTORY

DRILL FOR No. 6 x 5/8 SHEET METAL SCREWS (2 PLACES)

90° CAP OR 180° CAP (SEE NOTE 1)

90° CAP (SEE NOTE 3)

LCN 4810-18 LH (THIS SIDE UP) HINGE-EDGE

LCN 1/8" I.D. PNEUMATIC AIR TUBING

SEE NOTE 3

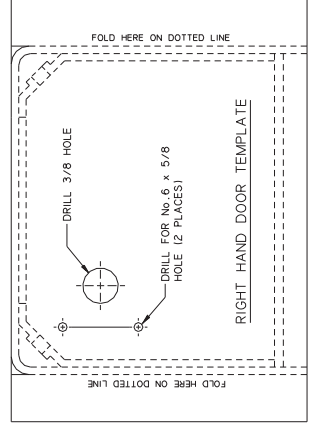
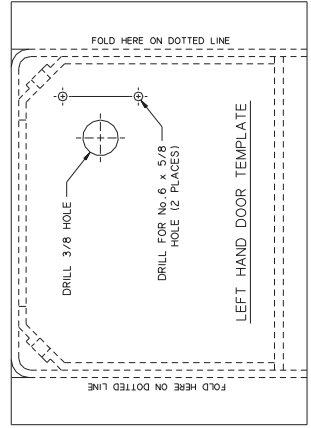

LEFT HAND SHOWN, RIGHT HAND OPPOSITE

No.	REVISION	BY DATE	APP BY
0	RELEASE NEW DRAWING	JEJ 18/15/95	JEJ 8/95
			DO NOT SCALE
PUSH SIDE MOUNTED AUTO-EQUALIZER® MOUNTED WITH PNEUMATIC DOOR LOOP			
<b>4840-459</b>			

**LCN®**



CL OF EPT IN FRAME MUST ALIGN WITH OF CL EPT IN DOOR.

WOOD: HOLES PREPARED DURING INSTALL.

METAL: #10-24 TAPPED HOLE (12 PLCS)

3 3/4 MAX. WHEN INSTALLED

7/8 FROM OUTSIDE FACE OF DOOR

RECOMMENDED 6" BELOW UPPER HINGE

REINFORCEMENT .060" (16 GA.) MINIMUM

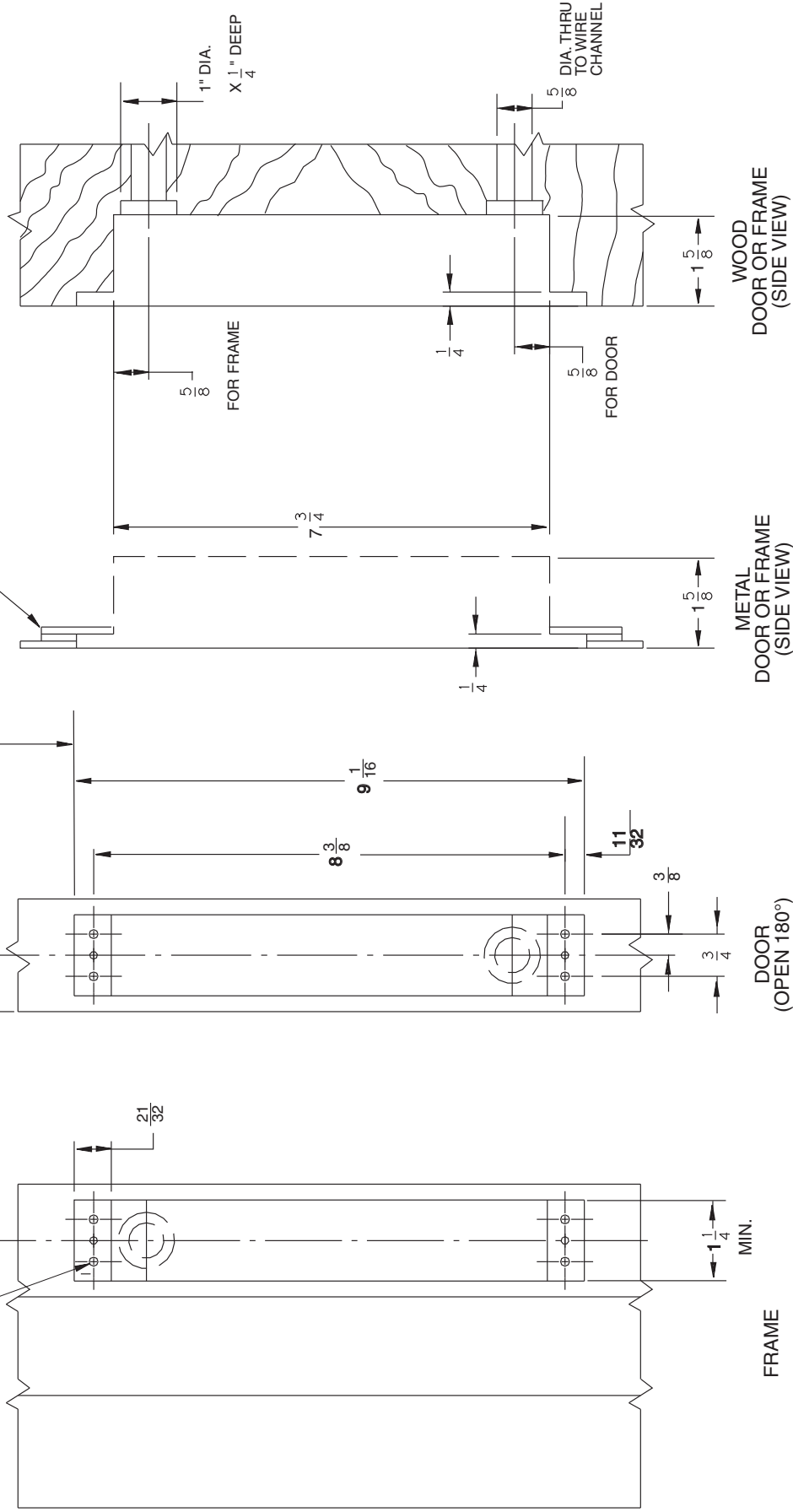

No.	REVISION	BY	DATE	APP BY	DATE
1	REDRAWN ON CAD	JEJ	8/1/95	KRF	9/09
2	REVISED FOR INSTRUCTION SHEET	AMM	1/20/98	DO NOT SCALE	
3	7/8 FROM OUTSIDE FACE OF DOOR	JDT	9/17/09		

**LCN®**

PNEUMATIC TRANSFER HINGE  
IN HOLLOW METAL DOOR AND FRAME

**4840-460**

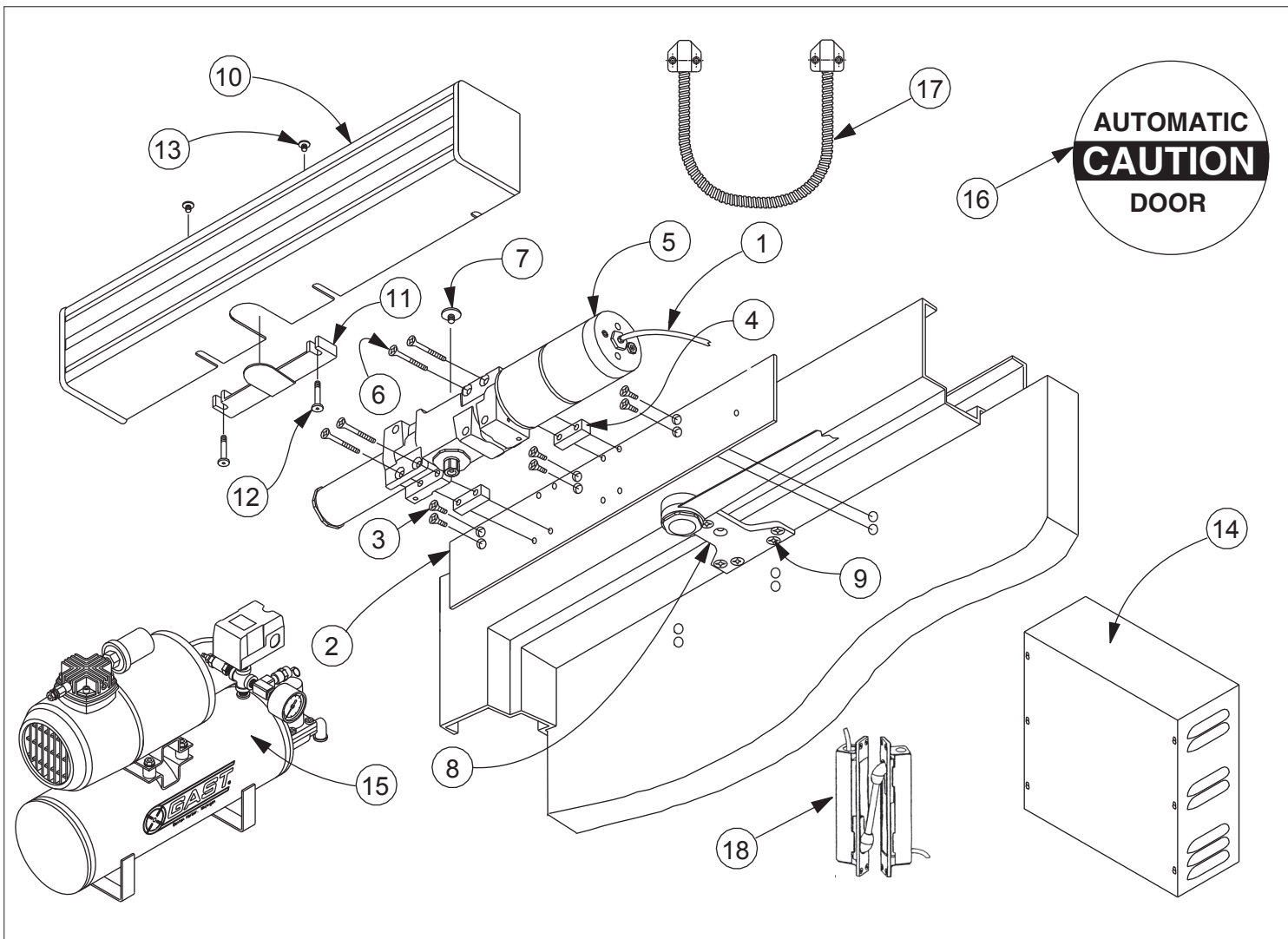

Item No.	Part No.	Description	Quantity
1	925	1/8 " I.D. Pneumatic Tubing	5' or 12' Section
2	4810-18	Standard Mounting Plate	1
3	No. 14 x 1 1/2" 1/4-20 x 5/8"	Phillips Head Wood Screw or Phillips Head Machine Screw	6
4	4810-182	Standoff	2
5	4840-3071	LCN Switch-Actuated Auto Equalizer	1
6	1/4-20 x 2 1/2"	Phillips Head Machine	4
7	4810-159	Arm Shaft S	1
8	4040SC-3035	Spring Cush Arm Assy.	1
	4040EDA-3035	Extra Duty Parallel Arm Assy.	
	4040CNS-3035G	Nonhanded Cush-N-Stop Assy.	
9	1/4-20 x 5/8"	Phillips Head Machine Screw	4
	1/4-20 x 1 1/2"	Phillips Head Machine Screw	1
	No.14 x 2 "	Phillips Head Wood Screw	5
10	4840-72	Cover	1
11	4840-163	Cover Insert	1
12	4810-31L	Long Cover Screw	2
13	4810-31	Cover Screw	2
14	7900 or 7980	Control Box	1
15	920 Series	Compressor (optional)	1
16	4820-155G	Decal	2
17	4840-459	Pneumatic Door Loop Kit (optional)	1 or
18	4840-460	Pneumatic Transfer Hinge Kit (optional)	1

If the proper hand door has been determined, cut out the appropriate template and place on the end cap.

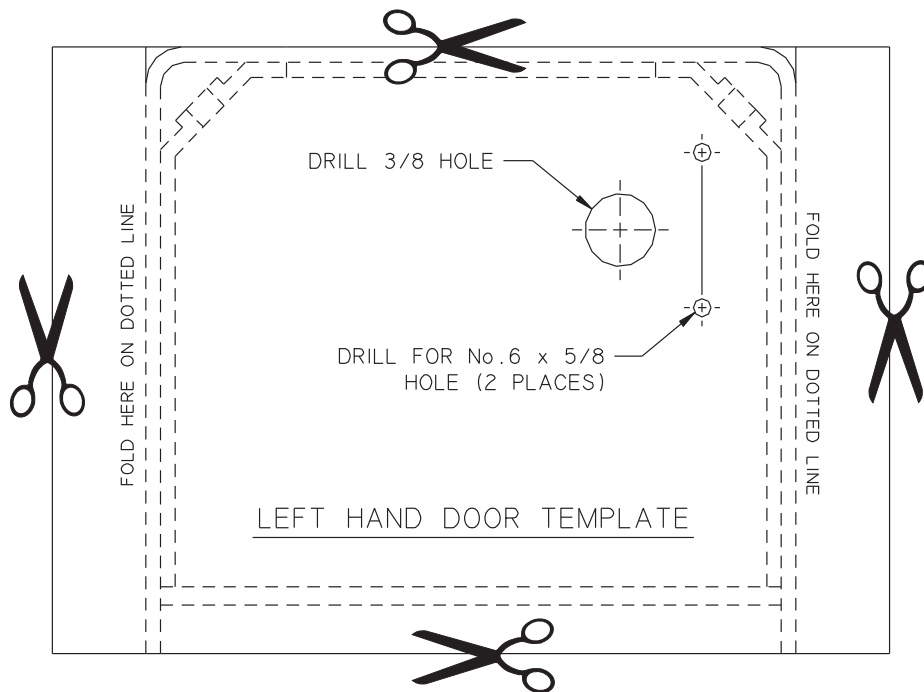
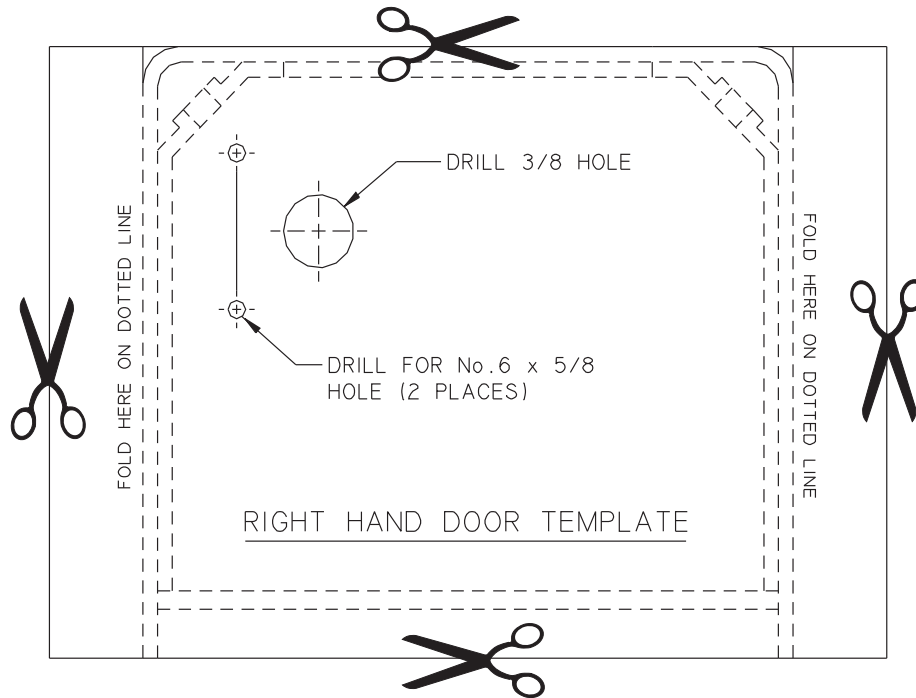

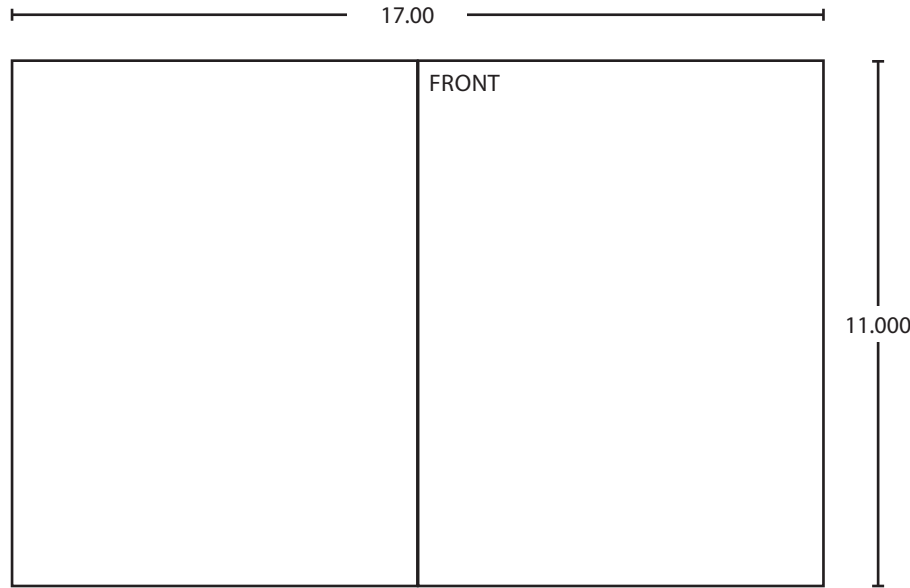

BEGINNING SHEET

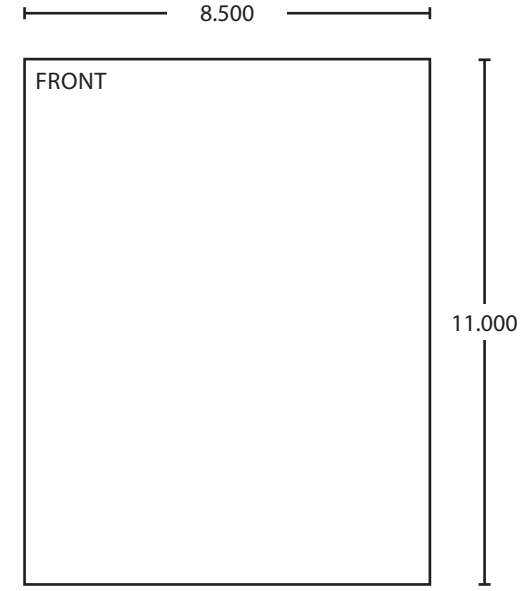

FOLDED SHEET

Additional Notes:
1. None

Revision History						Revision Description: G > Revised artwork						
G	H	J	K	L	M							
043812												
Material White Paper						Edited By D. Myers		Approved By M. Sasso		EC Number 043812	Release Date 01-01-14	
Notes 1. printed two sides 2. 12-Page Saddle-Stitched booklet 3. printed black 4. tolerance ± .13 5. printed in country may vary 6. drawings not to scale						Title 4840 Series Instruction Manual						
						Creation Date 04-27-10		Number 25381			Revision G	
						Created By N/A		Activity 3899 Hancock Expwy Security, CO 80911		© Allegion 2014		
						Software: InDesign CS6						