

Installation Instructions for 48H & 49H Mortise Locks

Overview

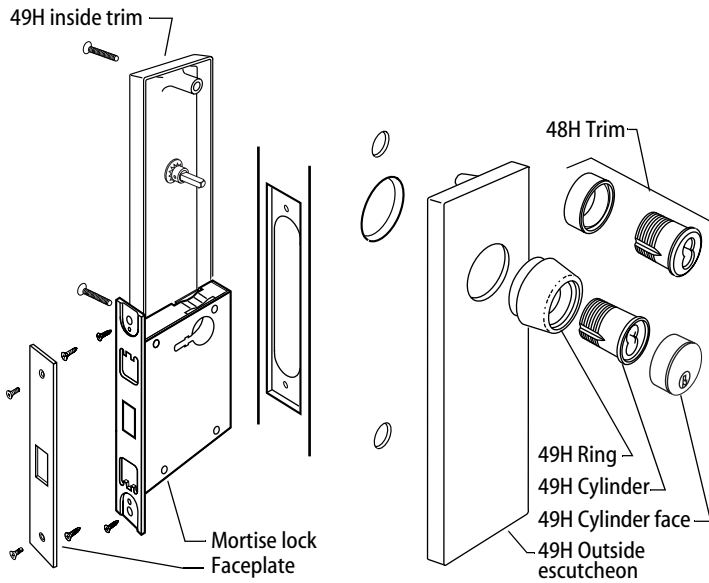

Figure 1 48H and 49H Mortise Lock overview diagram

1 Mark centerlines

Caution: If you use hollow metal doors, decide whether the doors are reinforced enough to support the lock. If the door reinforcement is not adequate, consult the door manufacturer about proper reinforcement.

Note: Prepare the door according to ANSI A115.1 before using these instructions.

- 1 Mark the horizontal centerline of the lock on both sides of the door and on the door's edge.

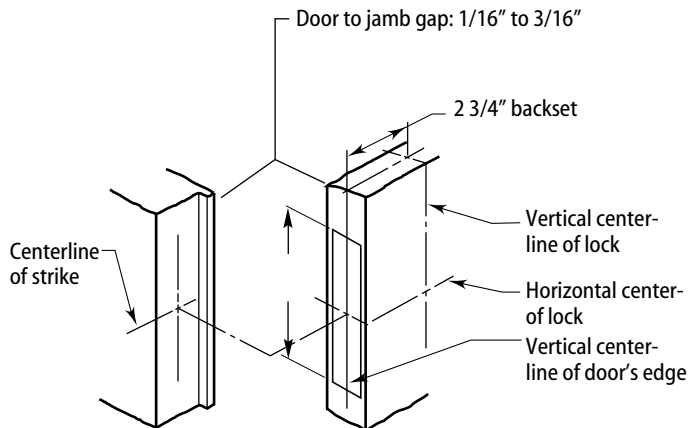

Figure 2 Marking the centerlines on the door

Note: BEST suggests a 38" height as measured from floor to lock centerline.

- 2 Mark the vertical centerline of the lock on the door edge.
- 3 Mark the vertical centerline of the lock on both sides of the door as measured from the vertical centerline on the door's edge.
- 4 Mark the horizontal centerline of the strike on the door jamb in line with the centerline of the lock.

2 Mark drill points

- 1 Cut the H18 template along the dotted line and align the horizontal and vertical arrows to the marked centerlines on the door.

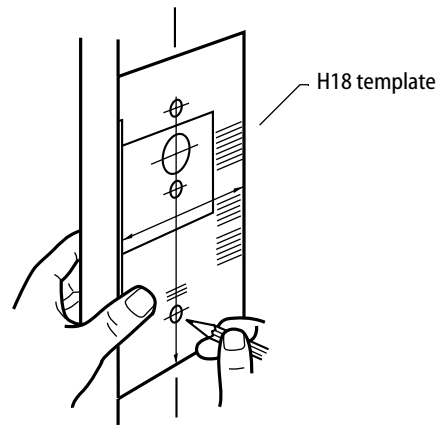

Figure 3 Marking the drill points with the template

- 2 Tape the template onto the door.

3 Install strike

- 1 Using the H18 template, mortise the jamb and install the strike and strike box. See *Installation Specifications*, Template H17 for dimensions.

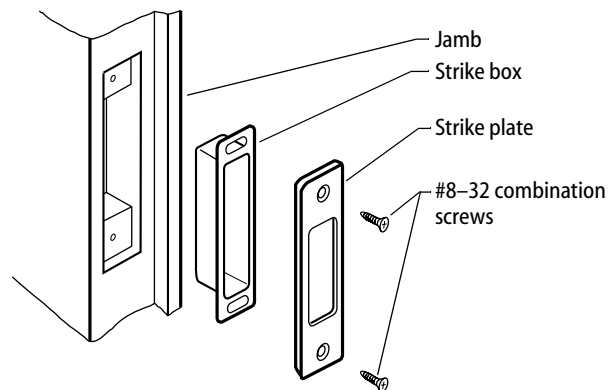

Figure 4 Installing the strike box and strike

4 Mortise and drill holes

- 1 Mortise the door for the lock case and faceplate.

Note: Check the lock for function before drilling.

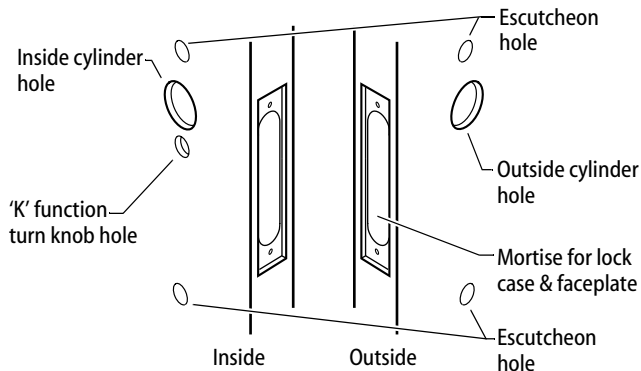

Figure 5 Mortising and drilling holes

- 2 Drill only those holes required for the lock function and trim. See Installation Specifications for hole requirements in Template H17.

5 Install mortise case

- 1 Remove the faceplate from the lock.

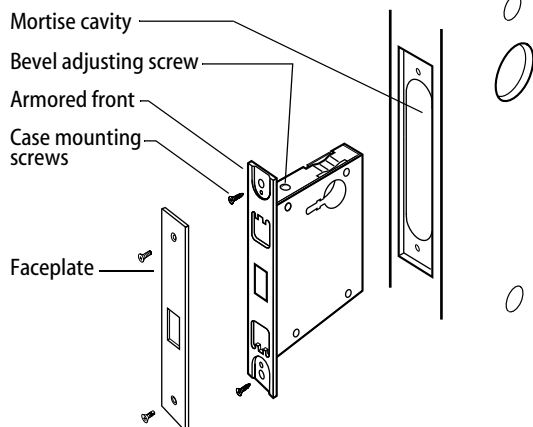

Figure 6 Installing the mortise case

- 2 Loosen the bevel adjusting screws on the top and bottom of the lock case and adjust the bevel of the armored front to match the door bevel. Retighten the screws.

For 'R' function only:

- Check the cylinder and lock for proper operation.

Caution: If the handing of the 'R' turn knob is incorrect, you can be locked in.

- 3 Install the lock into the mortise cavity.
- 4 Secure the lock case with the case mounting screws.

6 Install trim

To install 48H trim:

- 1 Install cylinder(s) and ring(s) and fasten with cylinder clamp screw(s).
- 2 Install thumb turn if needed.

- 3 Reinstall the faceplate.

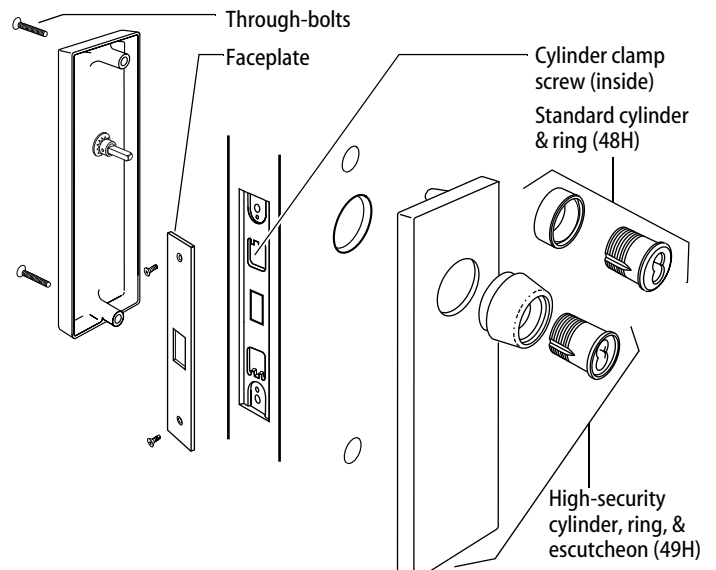

Figure 7 Installing 48H or 49H trim

- 4 Check the lock for proper operation.

To install 49H trim:

- 1 Position inside and outside escutcheons opposite each other and screw them loosely in place.
- 2 Put the high security cylinder(s) and ring(s) into the cylinder hole(s). Thread the cylinder(s) into the case until the cylinder head touches the inside rim of the ring.
- 3 Secure the cylinder(s) with the cylinder clamp screw(s).
- 4 Tighten the through-bolts.
- 5 Reinstall the faceplate.

7 Install core

For 5C cores only:

- Slide the cylinder face down over the 5C core.

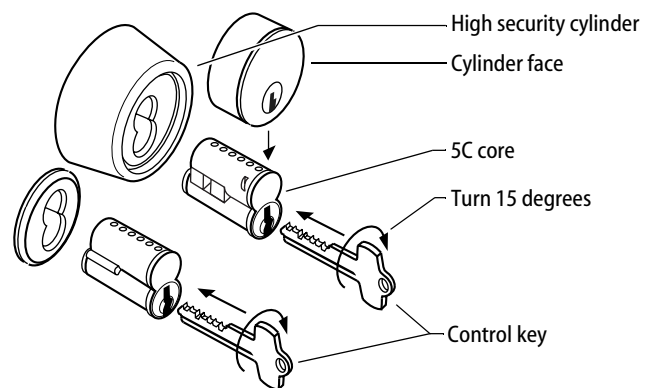

Figure 8 Installing the core

For all cores:

- 1 Put the control key into the core (or cylinder face) and turn the key 15 degrees clockwise.
- 2 Adjust the throw pins if needed, then put the core (and cylinder face) into the cylinder with the control key.
- 3 Turn the key 15 degrees counterclockwise and remove the key.

Note: Follow these steps to remove the core also.