

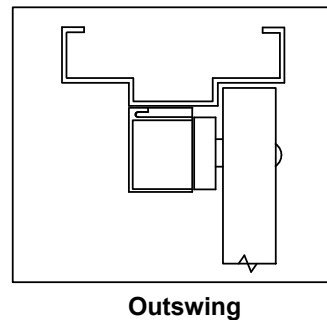

801 Avenida Acaso, Camarillo, Ca. 93012 • (805) 494-0622 •
www.sdcsecurity.com • E-mail: service@sdsecurity.com

INSTALLATION INSTRUCTIONS E1200 SERIES MAGNETIC LOCK

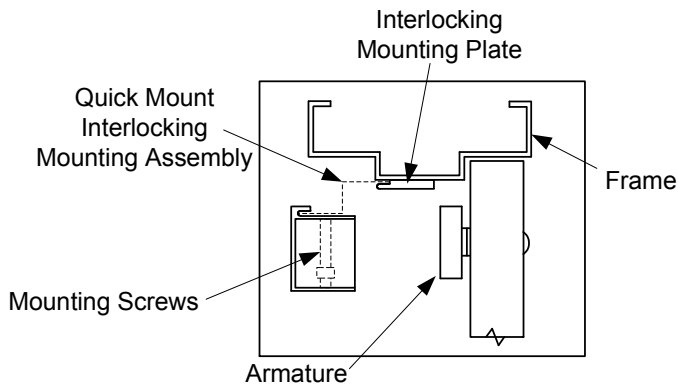
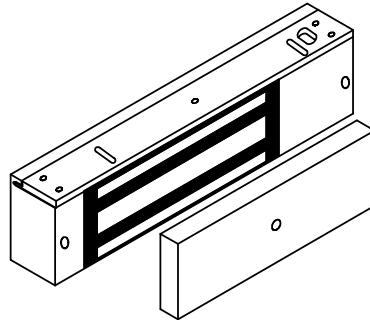

Electrical Instructions:

Use properly fused U. L. Listed Power Supply

Do not install a diode in parallel with any magnetic lock. A diode will cause a delay when releasing the door and residual magnetism to occur.

Although SDC recommends the use of a DC power supply, a transformer with an adjacent mounted full wave bridge rectifier may be used. A significant drop will occur when using a full wave bridge rectifier.

Any low voltage condition will cause erratic operation of the optional board sensor.

When using a full wave bridge rectifier all access controls and/or release contacts must be located between the EMlock and rectifier to ensure quick release.

Electrical Specifications:

Dual Voltage 12 or 24VDC

Power Consumption .500mA@12VDC
250mA@24VDC

DS Door Status Sensor SPDT, 500mA@30VDC
LS Lock Status Sensor SPDT, 2A@30VDC



Any suggestions or comments to this instruction or product are welcome. Please contact us through our website or email engineer@sdsecurity.com

1. Inspect the frame header to determine if mounting accessories are required (refer to page 4).
2. Fold template as indicated on dotted line. For single doors locate template against the door and header on the lock jamb side of the frame.
3. Mark and drill holes as indicated by the template.

STEPS 2 & 3

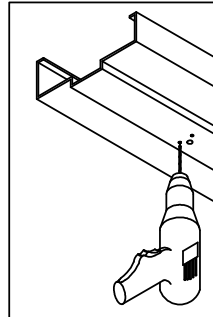
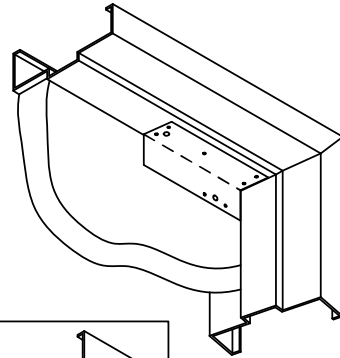
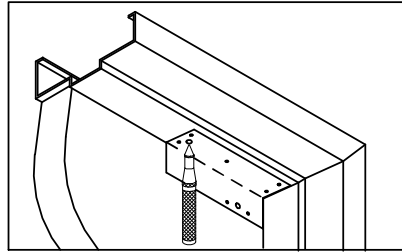

4. Mount armature to door.

STEP 4

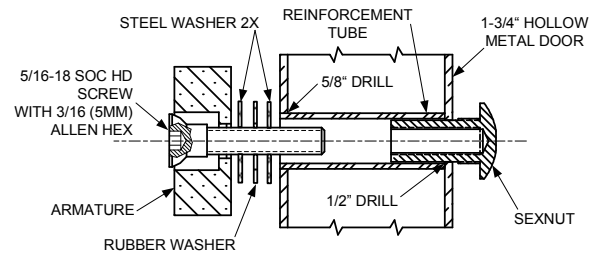
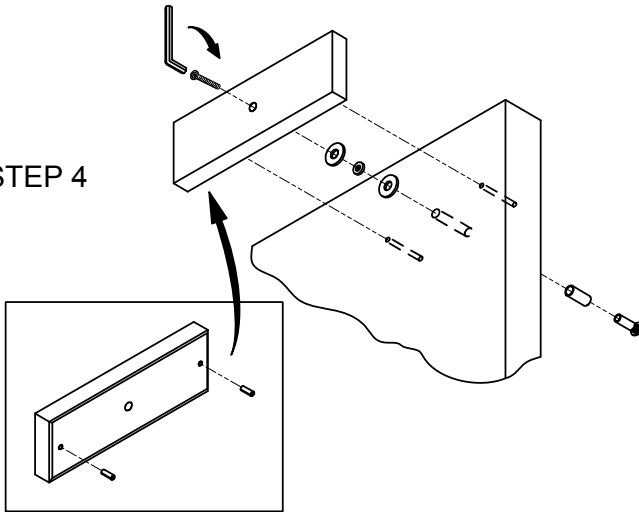

HOLLOW METAL DOOR

From Sexnut side of door, drill exactly 1/2" hole thru one metal thickness only. From Armature side of door, drill 5/8" hole to insert reinforcement tube. Press in sexnut and reinforcement tube all the way and mount armature to door using hardware provided.

5. Install magnet onto the header with the magnetic stripes towards the door side of the stop. Assure that the magnet and armature line up properly, then tighten down ALL mounting screws.

STEP 5

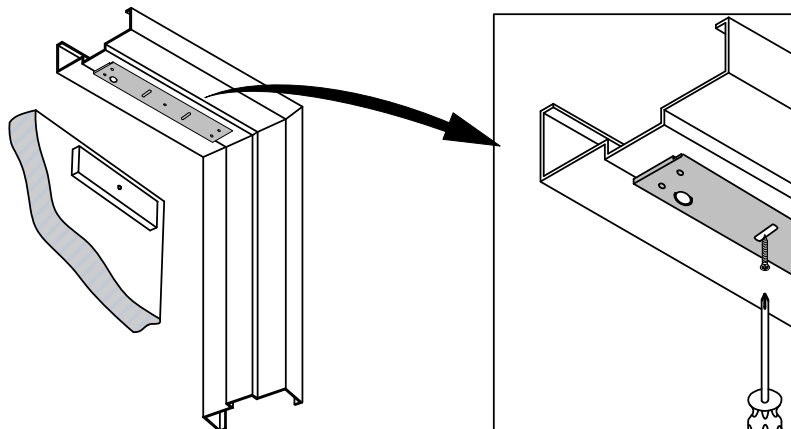

6. Holding the magnet housing at each end, engage the entire length of the interlock detail, by pushing towards the door. Tap with a soft hammer to ensure proper alignment and engagement.

CAUTION: The lock body must be held in place until secured with mounting screws. Secure socket head screws provided inside the housing at each end. Start screws into threads carefully to avoid stripping the threads. Check alignment and tighten screws. Pull wires through frame, mounting plate and magnet housing

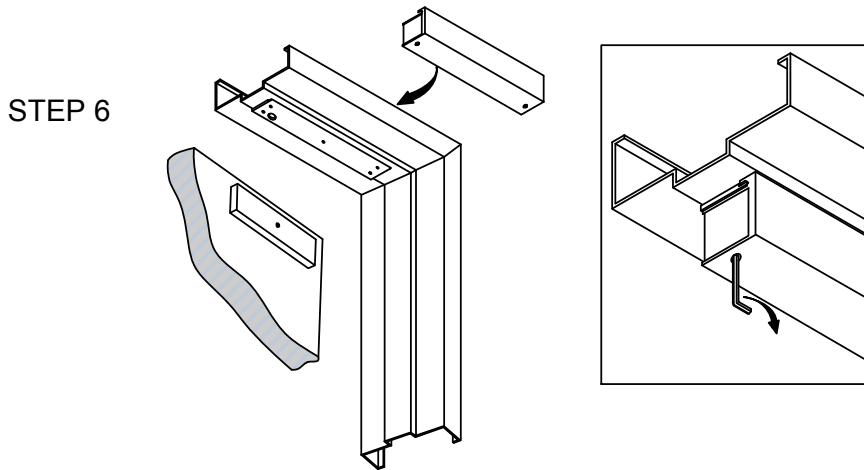

7. Select jumper position for 12VDC or 24VDC. Connect power to magnetic lock.

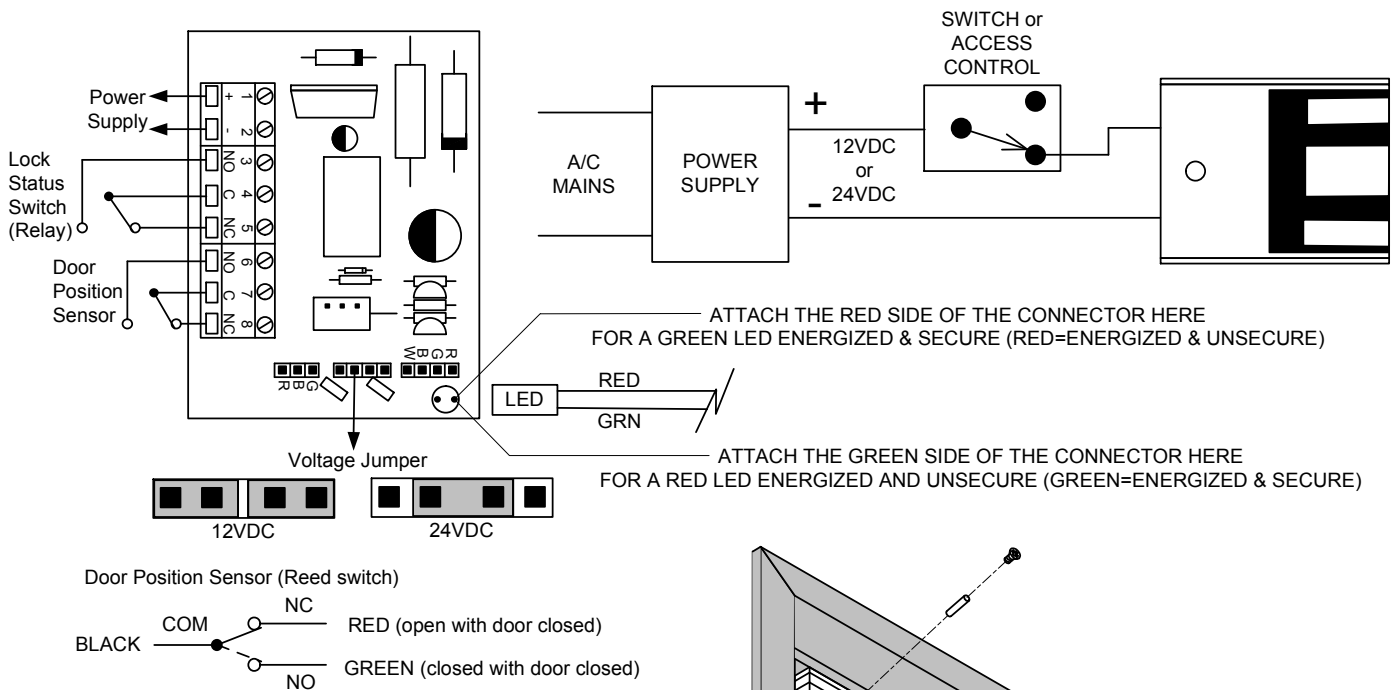

8. Test operation. When all is operating properly, tighten all screws as shown. Install security pins and screws as shown. Install anti-tamper plugs over socket head screws using a soft hammer to avoid damage to the housing.

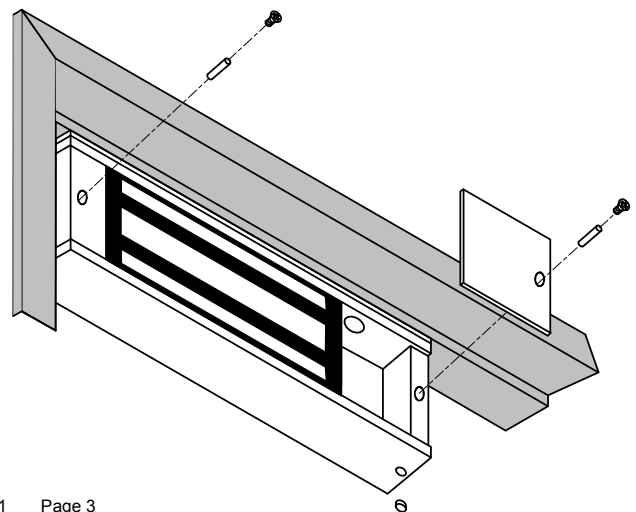

MOUNTING ACCESSORIES:

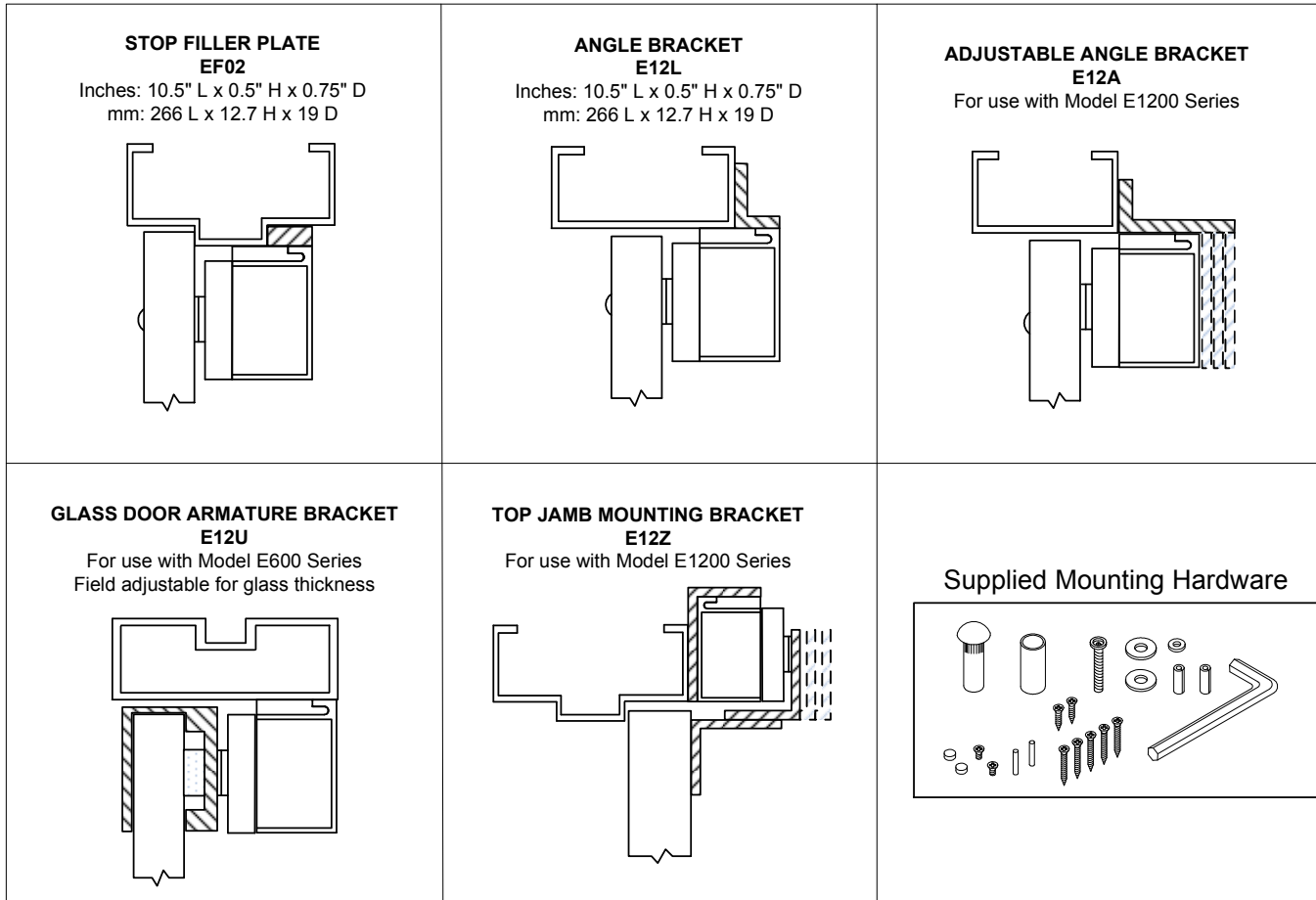

To maintain surface plating from corrosion:

- Do not touch the lock face with your hands.
- Clean lock face with Scotch-Brite pad by 3M (do not use sandpaper).
- Apply a thin film of rust inhibitor (LPS-3) on lock face.
- Repeat application on armature plate.