

Allowable Cutoff From Device Length	
Standard 36"	Standard 48"
4.75"	10.75"

INSTALLATION INSTRUCTIONS

1550K-MDV MOTOR DRIVE ELECTRIC LATCH RETRACTION KIT

FOR USE WITH VON DUPRIN 33A/35A AND 98/99 SERIES EXIT DEVICES

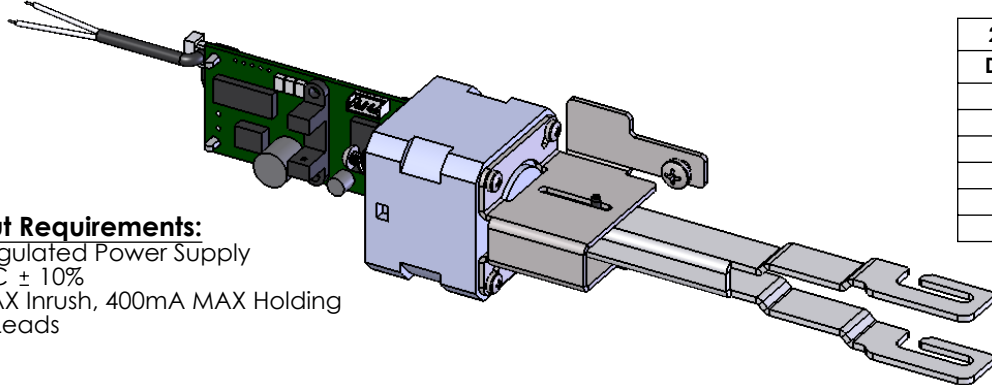

2-Conductor Wire Run	
Distance	Wire Gauge
70'	22
110'	20
180'	18
280'	16
450'	14
720'	12

Electrical Input Requirements:

Filtered and Regulated Power Supply
 Voltage: 24VDC \pm 10%
 Current: 1A MAX Inrush, 400mA MAX Holding
 Non-polarized Leads

PROVIDES SIMULTANEOUS ELECTRIC LATCH RETRACTION AND DOGGING (PUSH BAR DEPRESSED)

Installation:

1. Separate the mechanism case from the baseplate assembly.
2. Separate the push bar from the baseplate assembly.
3. Remove the manual dogging assembly, if present, from the baseplate assembly and discard.
4. Locate the 1550K-MDV Kit near the holes that secured the manual dogging assembly.
5. Attach the connecting link to the rear mechanism of the baseplate assembly.
6. Attach the motor bracket to the baseplate assembly using the supplied screws through the holes that secured the manual dogging assembly. **Do not tighten the screws.** This will allow the assembly to slide back into the mechanism case easily.
7. Attach the push bar to the baseplate assembly.
8. Attach the mechanism case to the baseplate assembly. Verify the flanges on the motor bracket are located with the baseplate assembly in the same mounting grooves of the mechanism case.
9. Tighten the motor bracket screws.
10. Apply the supplied technical assistance labels to the center case cover and the end cap cover. **Do not remove any regulatory labels adhered to the device.**

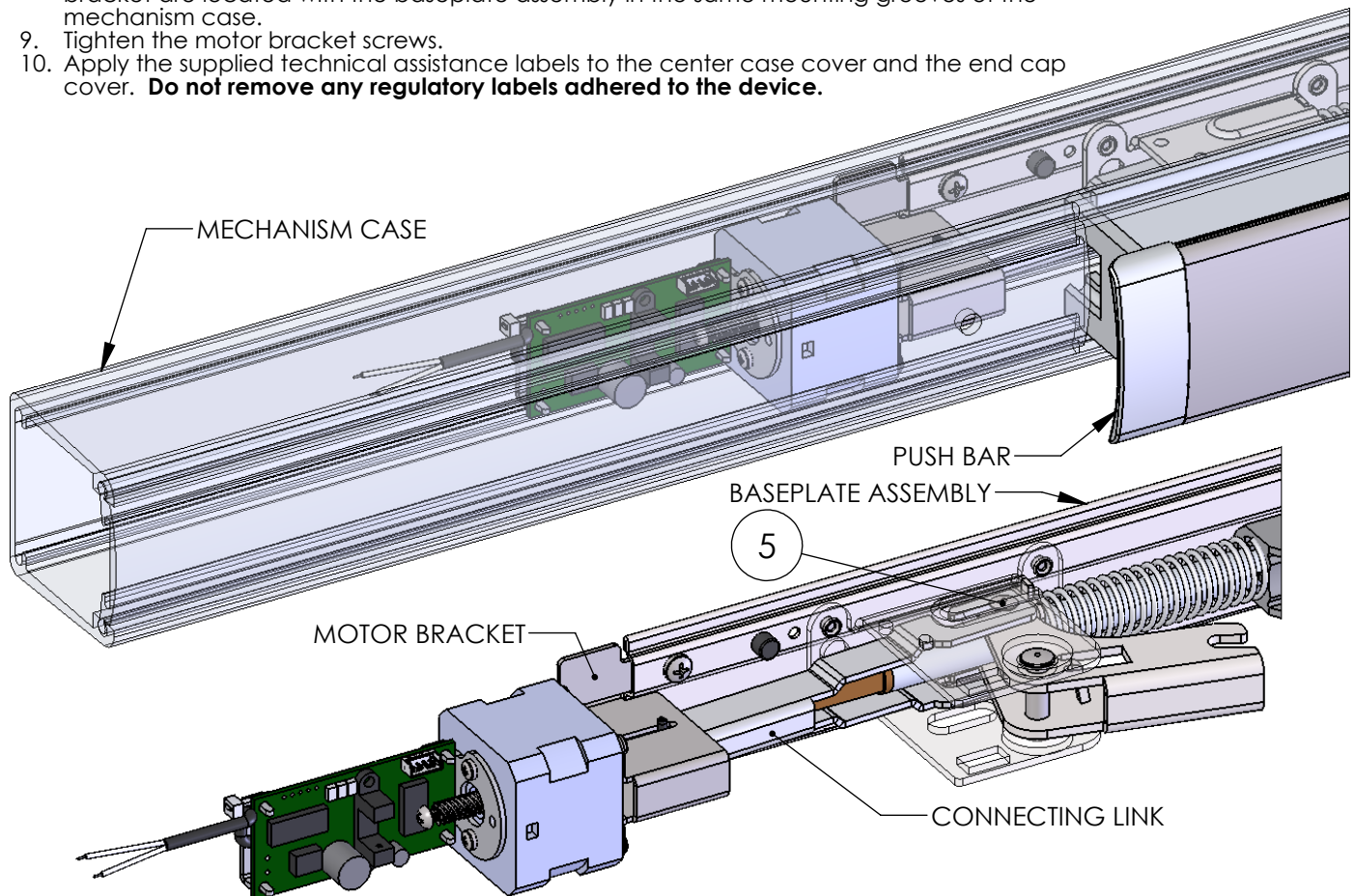

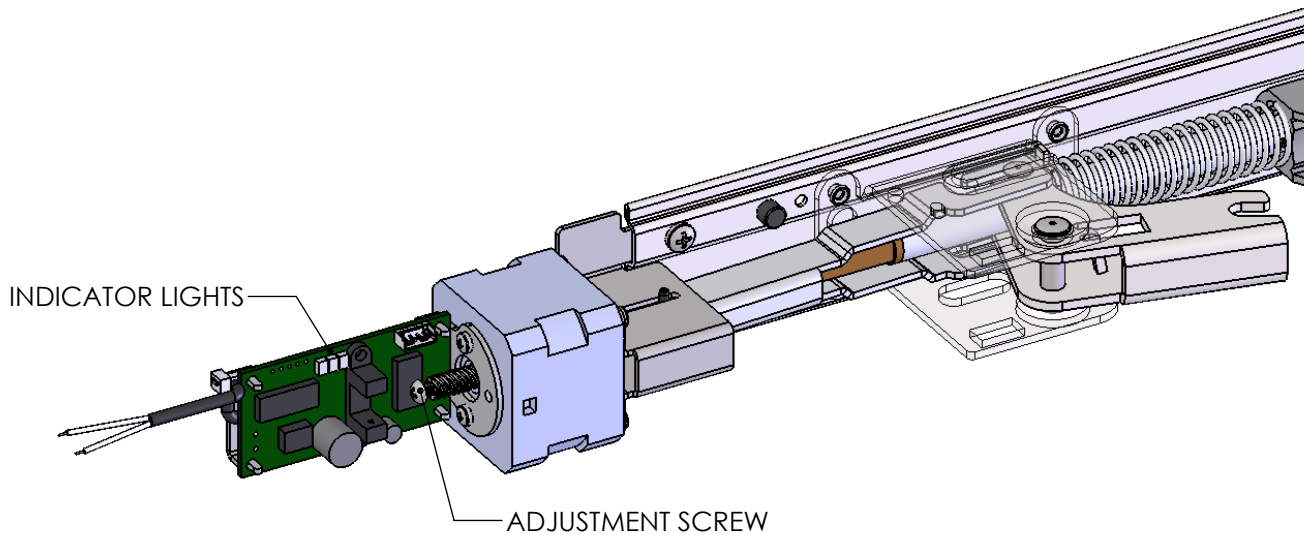

Motor Drive Electric Latch Retraction Adjustment:

1. Verify the device is properly adjusted for mechanical operation. Electric operation should not exceed the mechanical operation or there will be a high risk of damage to the device. **We suggest setting the latch retraction under electric operation at 1/16" less than the latch retraction under mechanical operation.**
2. Locate the adjustment screw in the rear of the motor assembly. Rotate the adjustment screw clockwise to increase the latch retraction or counterclockwise to decrease the latch retraction.

Onboard Indicator Light Assignments:

Maintain input power to the exit device and check the onboard indicator lights.

Remove input power before attempting a solution.

Green (Power)	Yellow (Sensor)	Red (Error)	Indication	Possible Solution
Off	Off	Off	No Power.	Connect the wiring between the power supply and the exit device.
On	On	Off	Normal Operation. The push bar is retracted to the dogged position and dogged; the latch is retracted by default. The device is allowed 2 attempts.	
On	Off	On	Error in operation. The push bar did not retract to the dogged position within 2 attempts.	Rotate the adjustment screw counterclockwise to decrease the latch retraction.
On	On	Blink	Error in operation. The push bar is retracted to the dogged position but not able to remain dogged. The device is allowed 5 attempts.	Rotate the adjustment screw counterclockwise to decrease the latch retraction.
On	On	On	Error in operation. Without power being removed, the push bar went from being dogged to unintentionally being extended, and then the push bar did not retract to the dogged position within 2 attempts.	Cycle the input power.
On	Blink	On	Error in operation. The push bar did not extend from the dogged position when the power was last removed. The device will not attempt a retraction.	Clear the jam condition manually and cycle the input power.