

# 5200 Electric Strike

Works with cylindrical locksets  
up to a 3/4" throw latchbolt

Also available in  
a Complete One  
Box Solution



## The Grade 1 solution with horizontal adjustability.

The 5200 Series Electric Strike features an in-frame horizontal adjustable design to simplify the installation process. This feature allows the installer to easily adjust the electric strike opening to accommodate the horizontal position of the latchbolt after the strike has been installed. This field selectable fail safe/fail secure unit is easy to install and accommodates latchbolts up to 3/4" throw.

## Features

### Standard Features

- Tamper resistant
- Static strength 1,500 lbs
- Dynamic strength 70 ft-lbs
- Endurance 1 million cycles
- Field selectable fail safe/fail secure
- In-frame horizontal adjustment
- Non-handed
- Internally mounted solenoid
- Accommodates 5/8" – 3/4" [15.9mm – 19mm] latchbolt (3/4" [19mm] with 1/8" [3.2mm] door gap)
- Strike body depth 1-3/16" [30.2mm]
- Plug-in connector
- Trim enhancer included
- SecuriCare five-year, no-fault, no questions asked warranty (Addition of SMART Pac® III extends the warranty to 10 years)

### Optional Features

- LBM Latchbolt monitor
- LBSM Latchbolt strike monitor

### Accessories

- 5200-500 Filler block for retrofit applications
- 150 Strike latch guard
- HES CUT-MTK Metal template kit
- 2001M Plug-in bridge rectifier
- 2004M ElectroLynx® adapter
- 2005M3 SMART Pac® III
- 2006M Plug-in buzzer
- 5204-1/2 1/2" [12.7mm] stackable lip extension
- 5204-1 1" [25.4mm] stackable lip extension
- 5204-1-1/4 1-1/4" [31.8mm] stackable lip extension



Grade 1

SecuriCare  
WarrantyCylindrical  
LocksetsSpecialty  
LocksetsField Selectable  
(Fail secure  
/Fail safe)Dual Voltage  
12/24PoE  
FriendlyBurglary  
Rated

ASSA ABLOY

## Specifications

### Certifications

- ANSI/BHMA A156.31, Grade 1
- UL 1034 burglary-resistant listed
- UL 294 listed
- RoHS compliant

### Frame Application

- Metal
- Wood

### Electrical (DC Continuous Duty)

- Dual voltage 12/24 VDC/VAC
- 240 mA at 12 VDC/120 mA at 24 VDC
- PoE friendly

## Dimensions

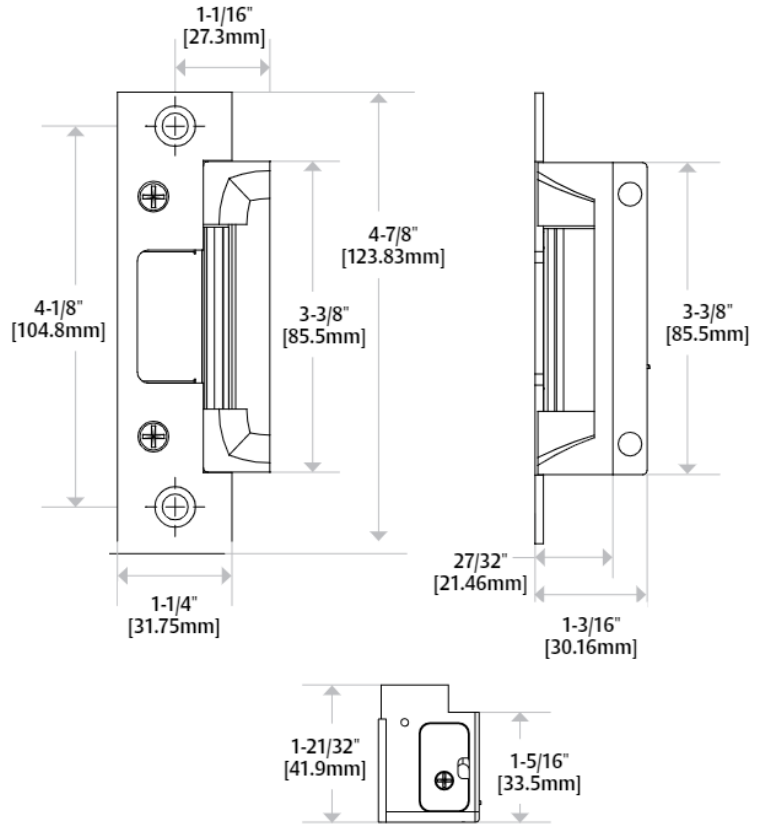

Diagram shown with 501 Option

## How to Order

SERIES	MODEL	FINISH	OPTION (S)
<b>5200</b>	—	<b>— 630</b>	<b>— LBM</b>
<b>5200</b> Universal Electric Strike; Faceplates ordered separately	<b>C*</b> Complete Electric Strike; includes the 501 and 501A faceplates	<b>605</b> Bright Brass <b>606</b> Satin Brass <b>612</b> Satin Bronze <b>613</b> Bronze Toned <b>629</b> Bright Stainless Steel <b>630</b> Satin Stainless Steel <b>BSP</b> Black Suede Powder	<b>(blank)</b> No Monitor <b>LBM</b> Latchbolt Monitor <b>LBSM</b> Latchbolt Strike Monitor

\*Complete Pacs are only available in the 630 finish

NOTE: Electric strike compatibility is determined at time of electric strike product release. ASSA ABLOY is not responsible for incompatibility of products that have changed in design or craftsmanship by their respective manufacturers. When compatibility is a concern, contact Customer Support for application assistance.