

Product Components

- ① 5000 Electric Strike Body
- ② 12 & 24 Volt Pigtails
- ③ Trim Enhancer (with screws)

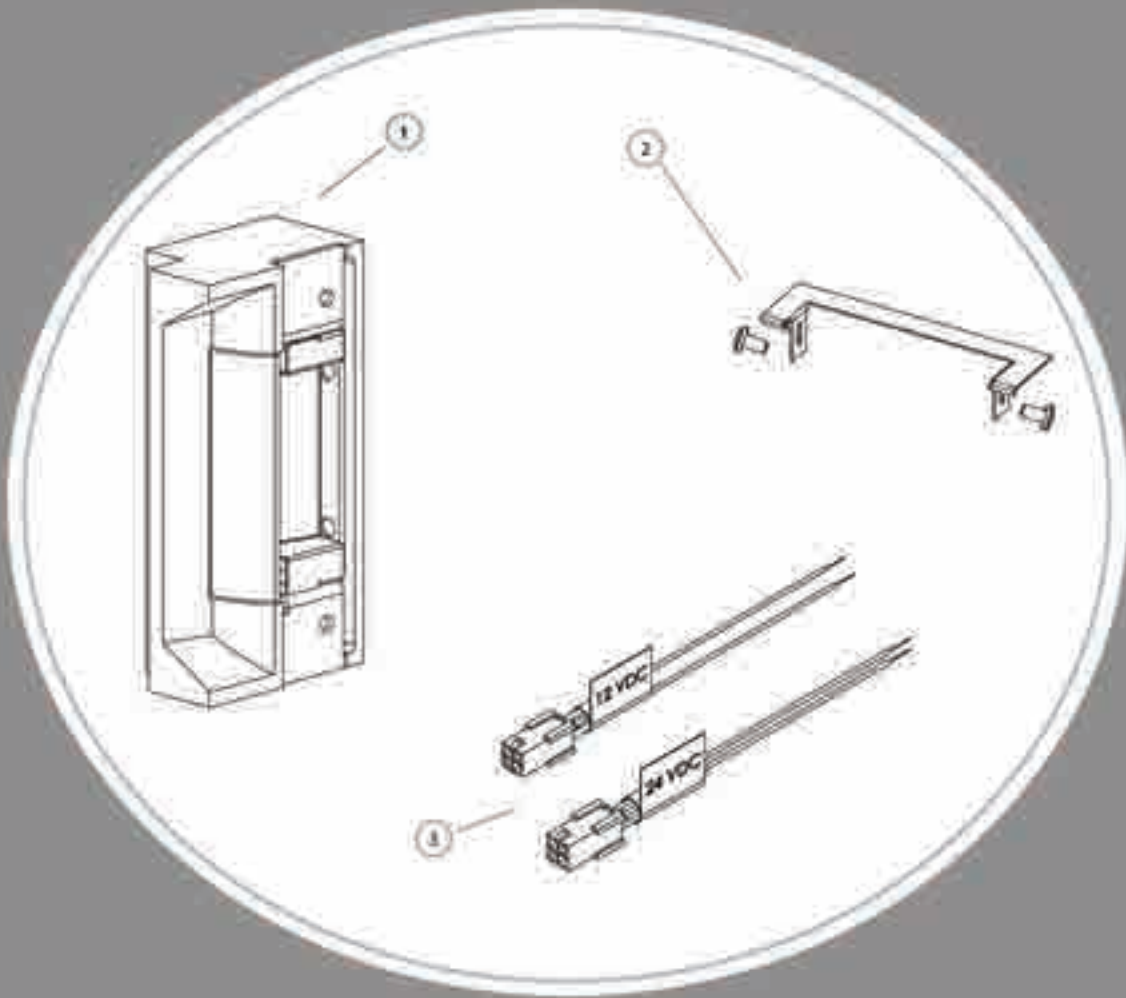

Diagram 1: Electrical Specifications

ELECTRICAL RATINGS FOR SOLENOID	CONTINUOUS DUTY		INTERMITTENT DUTY*	
	12VDC	24VDC	12-18VAC	24VAC
Resistance in Ohms	50	200	50	200
Amps	24	12	24-32	12

Solenoids are rated at +/- 10% indicated value.
*10% max duty cycle (2 min. max on time)
Indoor use only

MINIMUM WIRE GAUGE REQUIREMENTS	SOLENOID VOLTAGE	
	12VDC	24VDC
200 feet or less	18 gauge	20 gauge
200 - 300 feet	16 gauge	18 gauge
300 - 400 feet	14 gauge	16 gauge

CAUTION! Before connecting any device at the installation site, verify input voltage using a multimeter. Many power supplies and low voltage transformers operate at higher levels than listed. Any input voltage exceeding 10% of the solenoid rating may cause severe damage to the unit and will void the warranty.

Prepare Strike

1. Select the appropriate Plug In Connector that matches system power and electrically connect as illustrated in Diagram 2. For 12V AC/DC or 16V AC, the pigtail marked "12 VDC" should be used. For 24V AC/DC, the pigtail marked "24 VDC" should be used.
2. Verify that the strike is in the correct mode of operation. This unit ships in Fail Secure mode. If you need to convert to Fail Safe see Diagram 4.
3. If using Latchbolt Monitor (LBM) see Diagram 3 to complete wiring.

Prepare Frame

4. Prepare frame using appropriate template for your faceplate (see pages 3-6).

5. Attach faceplate to strike body

Finish Installing

6. Connect wires from the power source to the strike.
7. Install the electric strike unit in jamb cutout using the screws provided with the faceplate option kit.

DIAGRAM 2: 12V to 24V CONVERSION

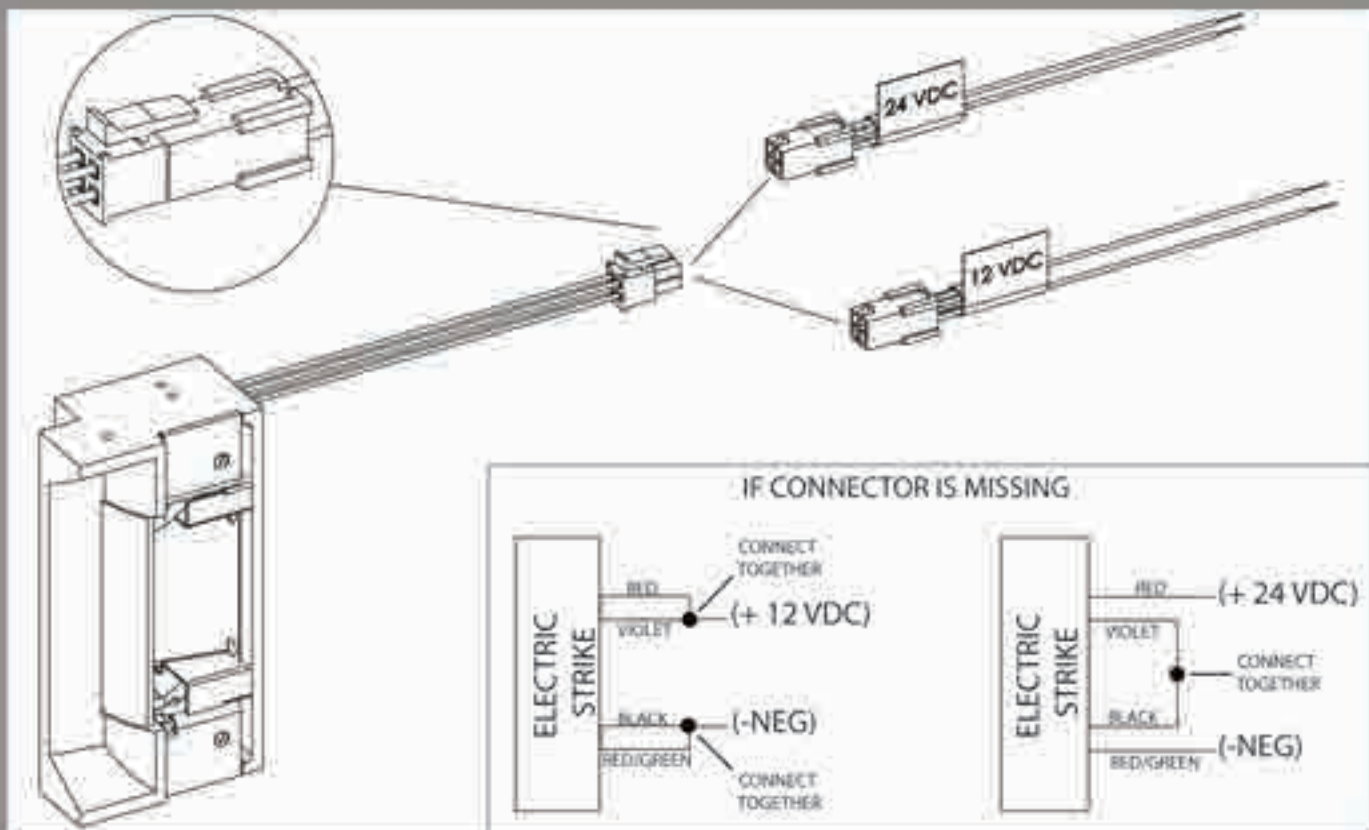
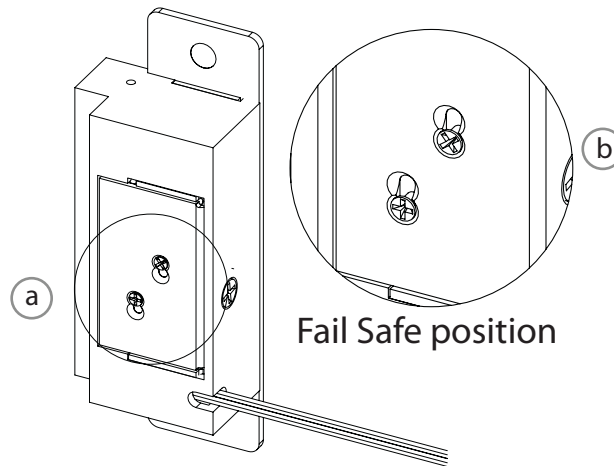

DIAGRAM 3: LATCHBOLT MONITOR

LBM WIRING	
White	Common
Orange	Normally Open
Green	Normally Closed



DIAGRAM 4: FAIL SAFE CONVERSION



Convert Mode

- Loosen the two #2-56 screws located on the back of the strike as shown above, but do not remove them.
- Move screws from the top of the hole (Fail Secure position) to the bottom hole (Fail Safe position) as shown above.
- Tighten screws.

Verify

- Verify the strike is now in the Fail Safe operation mode. If the strike still operates as Fail Secure, be sure screws are fully seated in the bottom position.

5000 with 501 Faceplate

4-7/8" x 1-1/4" Square Corner Faceplate
ANSI Metal Jamb Installations

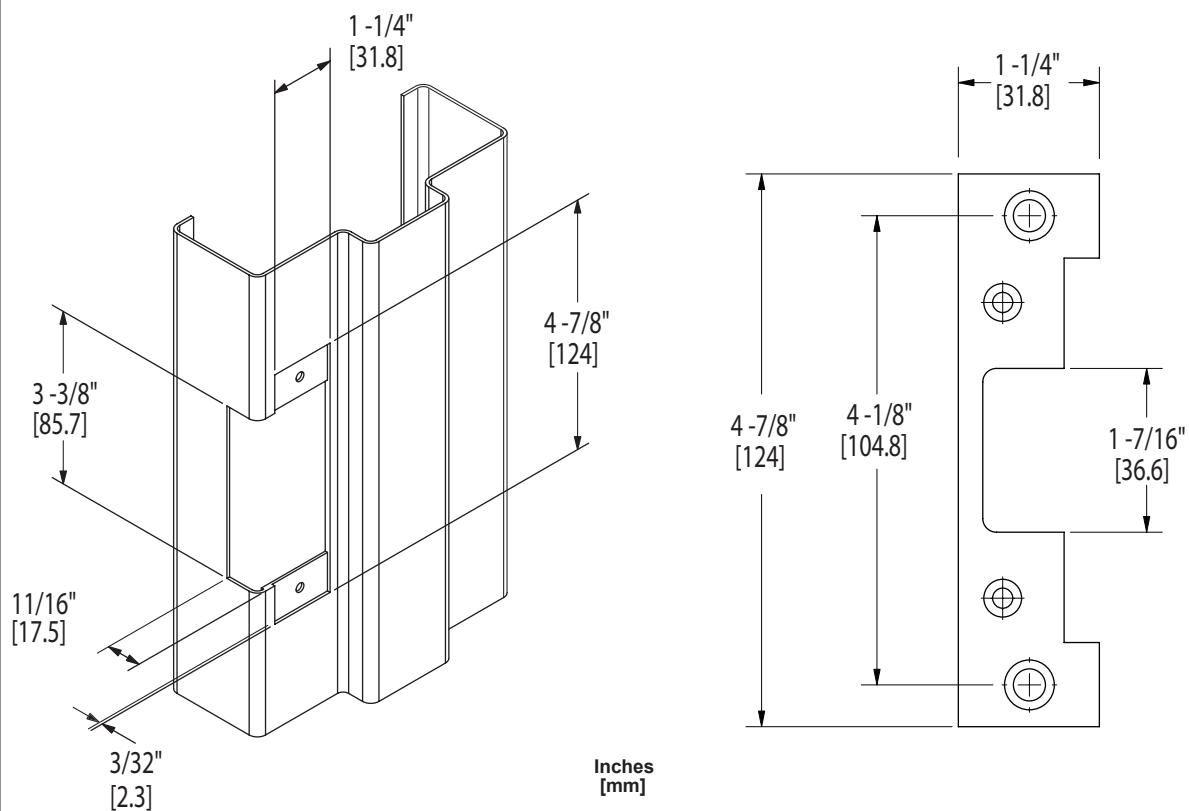

5000 with 501A Faceplate

4-7/8" x 1-1/4" Radius Corner Faceplate
Aluminum Jamb Installations

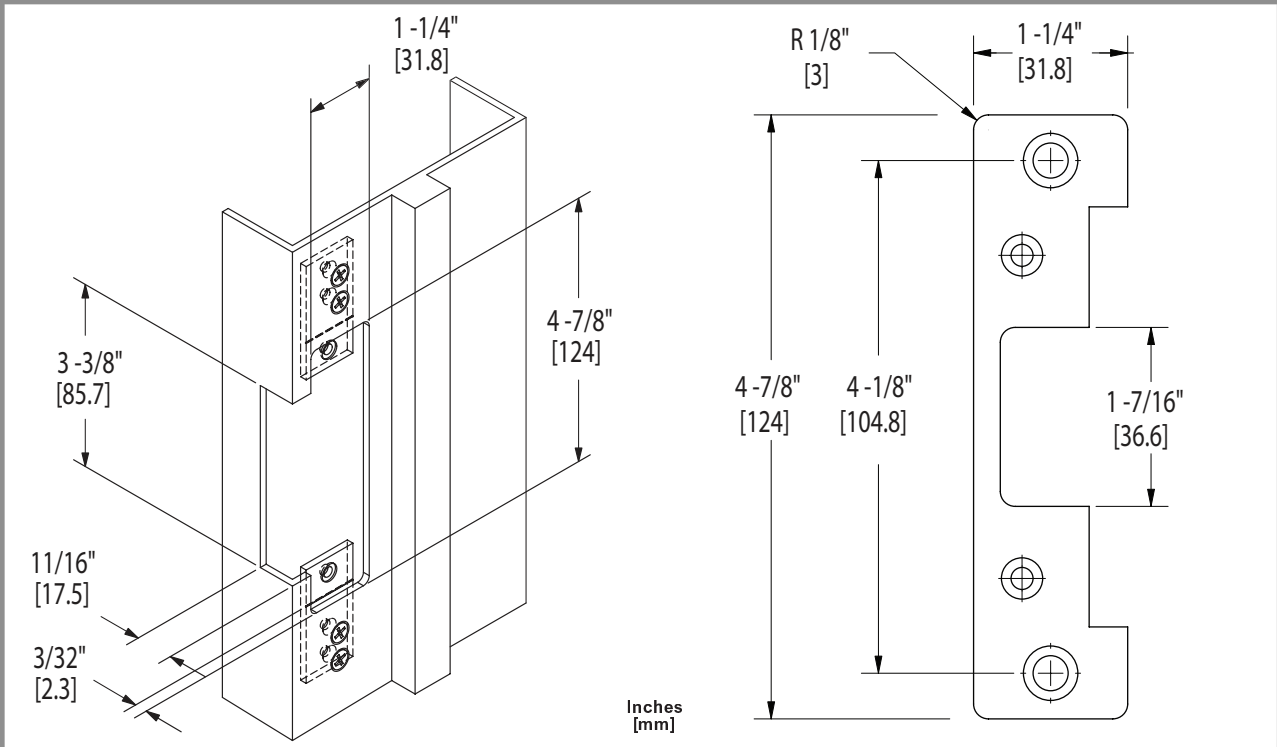

5000 with 502 Faceplate

7-15/16" x 1-7/16" Radius Corner Faceplate
Aluminum Frame Installations

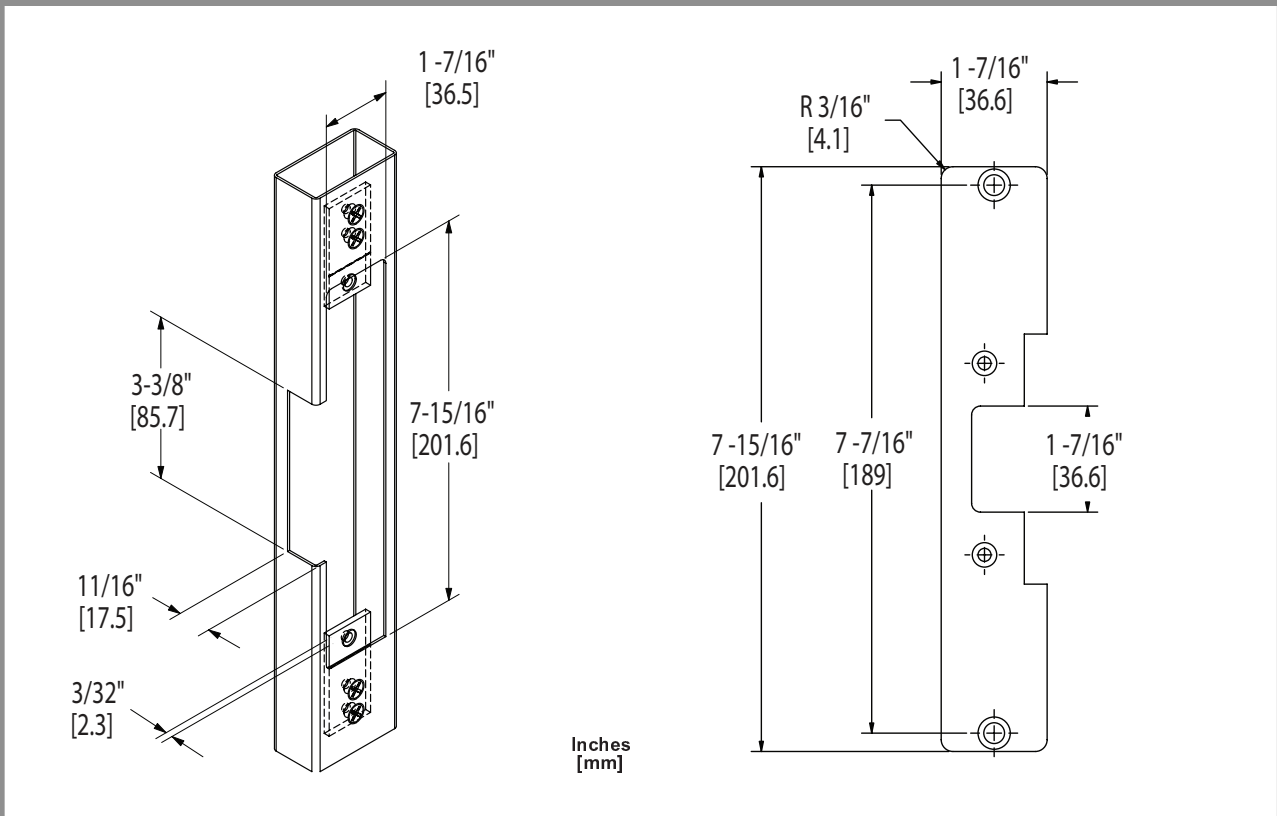

5000 with 503 Faceplate

6-7/8" x 1-1/4" Radius Corner Faceplate
Aluminum Frame Installations

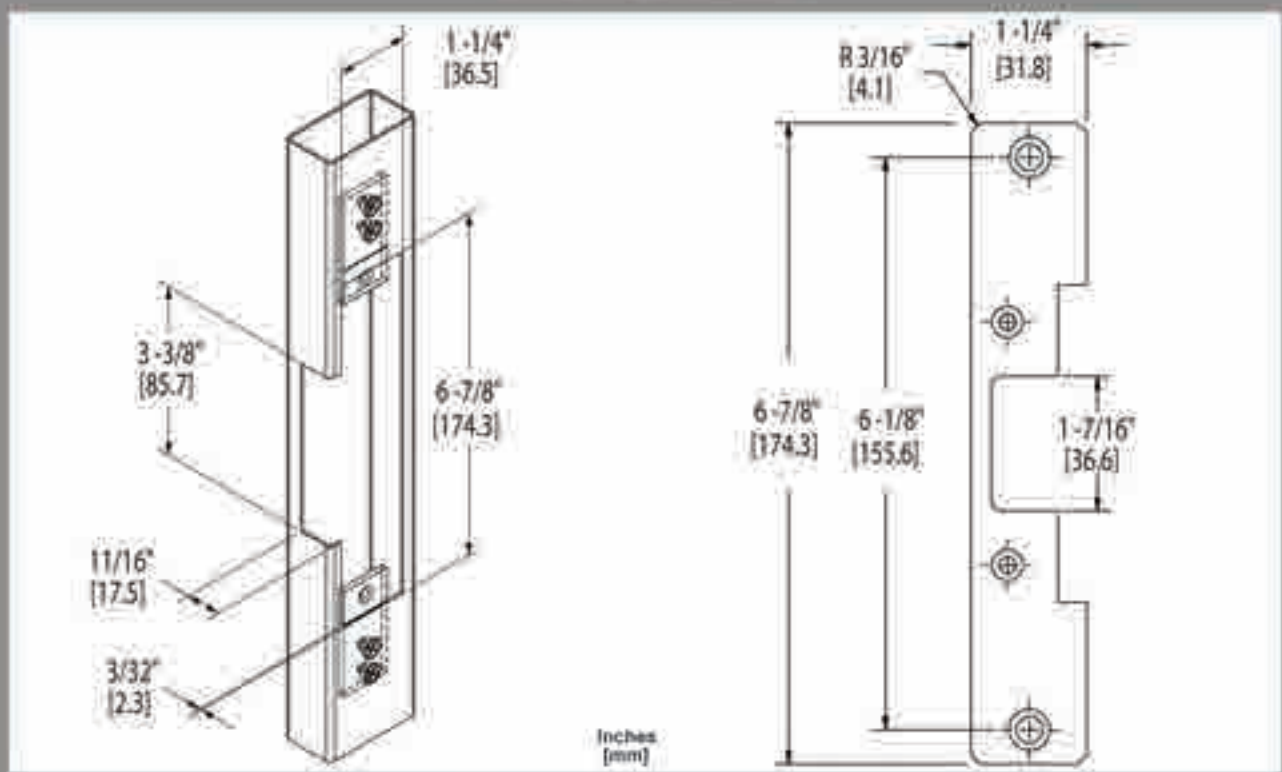

5000 with 504 Faceplate

10" x 1-3/8" Radius Corner & Flat Faceplate
Wood Frame Installations

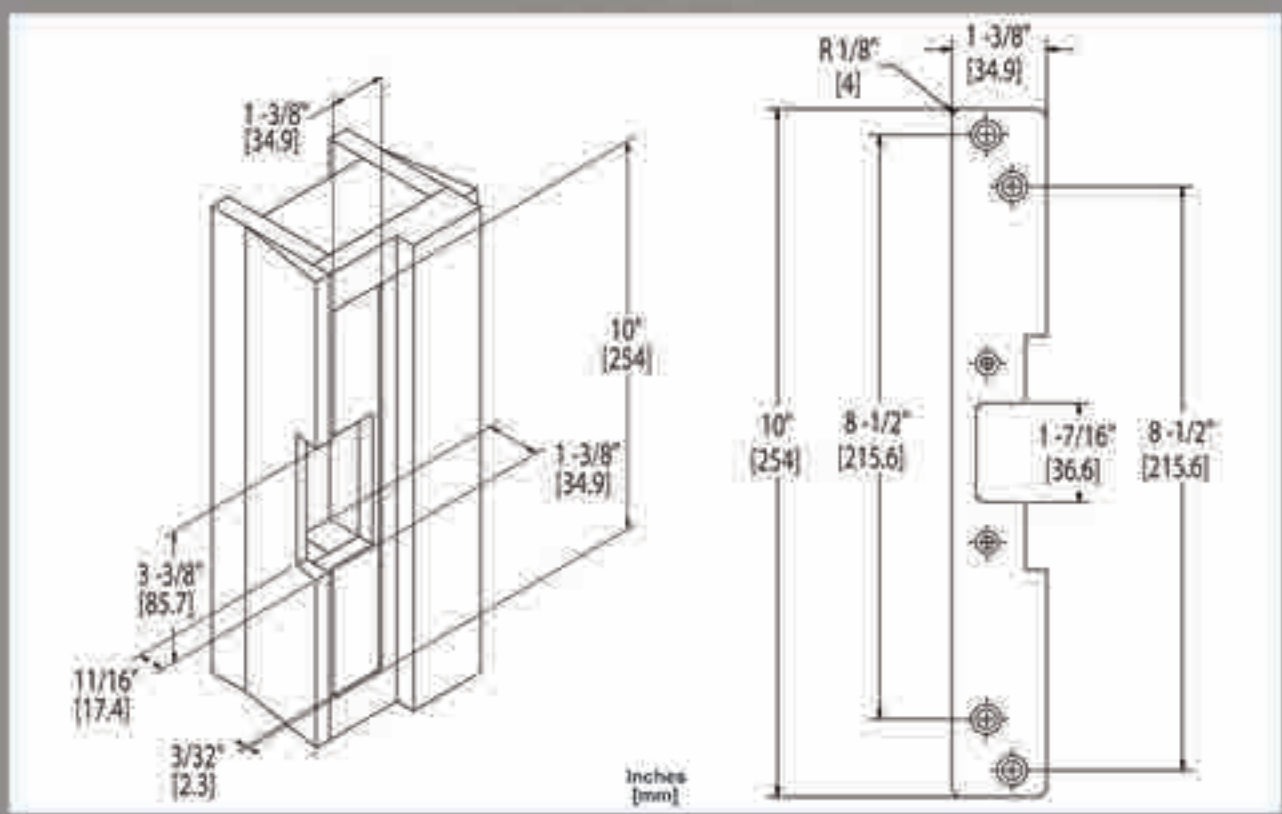

This page Intentionally
left blank