



Specialty Locks

GL1 Gate Lock

Electromechanical gate solution offers one ton of holding power



The heavy duty GL1 Electromechanical Gate Lock provides weather-resistant access control for a wide range of gate applications.

The GL1 provides 2,000 lbs of holding force for electrical and manually operated indoor or outdoor gates where preload is a concern. Ideal for swinging or sliding vehicle, pedestrian or stock gate access control.

Features

Standard Features

- 2,000 lbs holding force
- Operates under preload up to 100 lbs
- Automatic dual-voltage—no field adjustment required
- Accepts a standard mortise cylinder with Adams Rite MS cam for manual key override (not included, see spacer guide below)
- Self-aligning receiver (+/- 1/2" [12.7mm] horizontally) helps compensate for gate misalignment and sag
- Tamper resistant cast housing
- Optional latch status monitor
- Surface mount
- MagnaCare® lifetime replacement, no-fault, no questions asked warranty

Optional Features

- **FL** Fail locked
- **FS** Fail safe
- **M** Monitoring option

Mortise Spacer Guide

CYLINDER LENGTH	SPACER REQUIRED
1" [25.4mm]	1/4" [6.35mm]
1-1/8" [28.5mm]	3/8" [9.5mm]
1-1/4" [31.75mm]	1/2" [12.7mm]

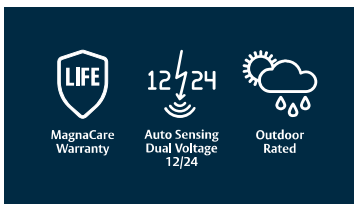

GL1 Gate Lock

Specifications

Certifications

- UL 294 Listed

Electrical

- 12 Volts Initial (*Peak*): (~1.0 sec.) at 870 mA — Reduced: 290 mA
- 24 Volts Initial (*Peak*): (~1.0 sec.) at 720 mA — Reduced: 170 mA

Holding Force

- 2,000 lbs [907kg]

Operating Temperature

- -58° to 167°F [-50° to 75°C]
- Indoor or outdoor use

Shipping Weight

- 6 lbs [2.72 kg]

Dimensions

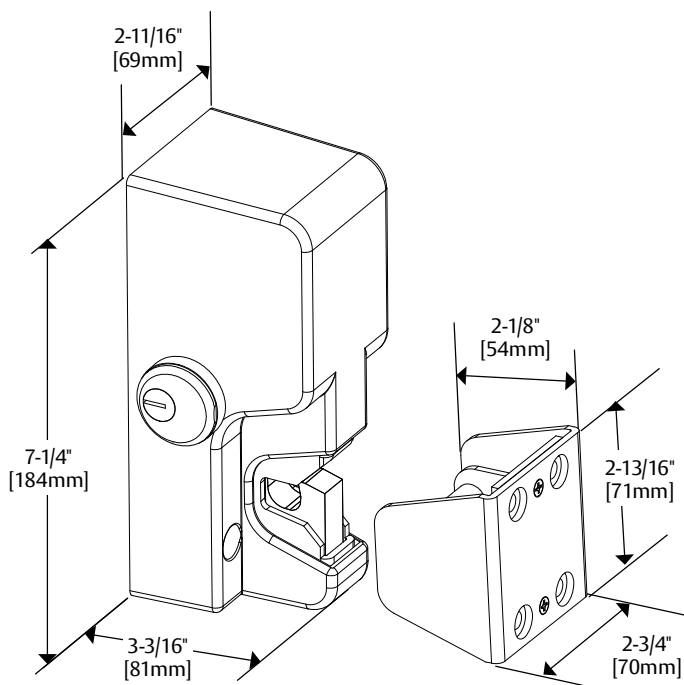

How to Order

MODEL SERIES	LOCK FAIL STATE	MONITORING OPTIONS
GL1	- FS	M
GL1	FL Fail Locked (Fail Secure)	(blank) No Monitoring
	FS Fail Safe	M Monitored

Sliding Gate GL1 with FMK-SL (sold separately) for sliding gates

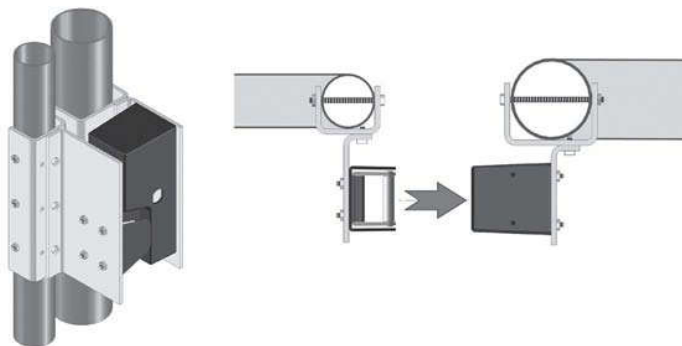

Swinging Gate GL1 with FMK-SW (sold separately) for swinging gates

