

ASSA ABLOY

EPT-SC SERIES ELECTRICAL POWER TRANSFER FOR SWING CLEAR HINGED DOOR APPLICATIONS - INSTALLATION INSTRUCTIONS

1 DESCRIPTION

The EPT-SC allows an electric lock or exit device, such as a Securitron Touch Sense Bar or Touch Sense Handle, to be installed while concealing and protecting the cabling between the hinged edge of a door and its door frame. The EPT-SC provides a flexible steel shield conduit which is approximately 5/16" [7,9mm] I.D. (inside diameter). The EL-EPT-SC is furnished with a wire harness already installed which includes ElectroLynx® connectors at each end.

The EPT-SC power transfer device has been specifically designed and configured for installation on doors using Swing Clear type hinges.

Note: The EPT-SC will NOT work on doors utilizing center pivot type hinges.

2 PRODUCT OVERVIEW

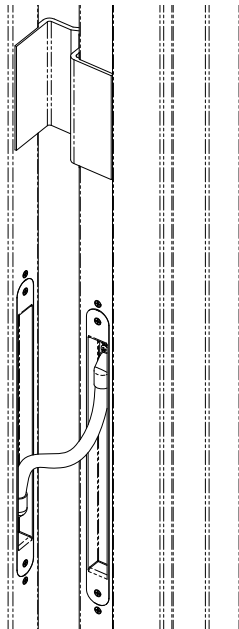

Upon unpacking this product, an inventory should be made to ensure that all of the required components have been included. Along with these instructions and the installation template, this product should include the following items:

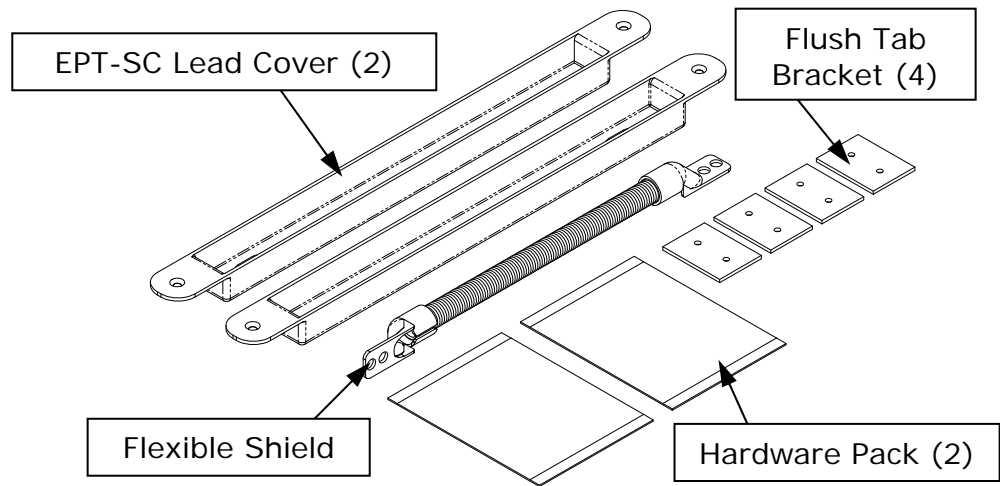

2.1 HARDWARE

8X	8X	4X	4X
Phillips Flat Head #6 X 5/8" Type "A"	Phillips Flat Head 6-32 X 3/8" Type "F"	Phillips Pan Head 8-32 X 3/16"	Split Helical Washer for #8 Screw

3 RECOMMENDED TOOLS

- | | |
|-------------------------------------|---|
| Router or Saber Saw | Measuring Instrument (Ruler/Tape Measure) |
| Hammer | Masking Tape |
| Chisel | Fish Tape or Lead Wire |
| Center Punch | Wire Strippers/Cutter |
| Power Drill | Crimp Wire Connectors |
| 1/8", 5/32" and 3/4" Drill Bits | Crimp Tool |
| 3/8" Diameter X 82° Countersink Bit | Multimeter |
| Phillips and Standard Screwdrivers | |

4 INSTALLATION

For a proper EPT-SC install, all doors and frames must utilize a flush surface mount installation. If the door/frame is pre-prepped by the manufacturer, then use the pre-fabricated mounting features and the hardware provided to install the EPT-SC as discussed in Section 4.3 or 4.4. If the installation is a field retrofit, determine the door and frame construction, then proceed to mark the door and frame in accordance with Section 4.1.

4.1 Vertical Placement

Because of potential structural obstacles within metal doors and frames, the EPT-SC lead covers should be positioned a minimum of 6" [152,4mm] from the any hinge recess (as shown in **Figure 2**) or centered between hinges.

Note: Due to variances in manufacturing, the door/frame manufacturer should be consulted for specific construction and configuration information.

4.2 Marking the Door and Frame for Install

- Mark a vertical centerline for the EPT-SC lead cover at the center of the door edge. Measure the distance from this mark to the edge of the hinge half that is attached to the door (see "X" of "DOOR" prep. in **Figure 1** or **Figure 2**). Use this same distance to mark from the edge of the hinge half on the frame (see "X" of "FRAME" prep. In **Figure 1** or **Figure 2**).
- Using the included template and the information shown in **Figure 1** (for wood) or **Figure 2** (for metal), align and mark the cutout positions required for the lead covers on both the door edge and the frame.

Note: Because of the nature of the Swing Clear hinges and the orientation of the edge of the door in the open position, the door will most likely need to be removed after marking to perform the preparation process for the lead cover installation.

4.3 Wood Doors and Frames:

- Using a router with a 1/4" diameter bit, cut the main recess slot into the edge of the door and the frame to a depth of .700" [17,8mm] as shown in **Figure 1**.

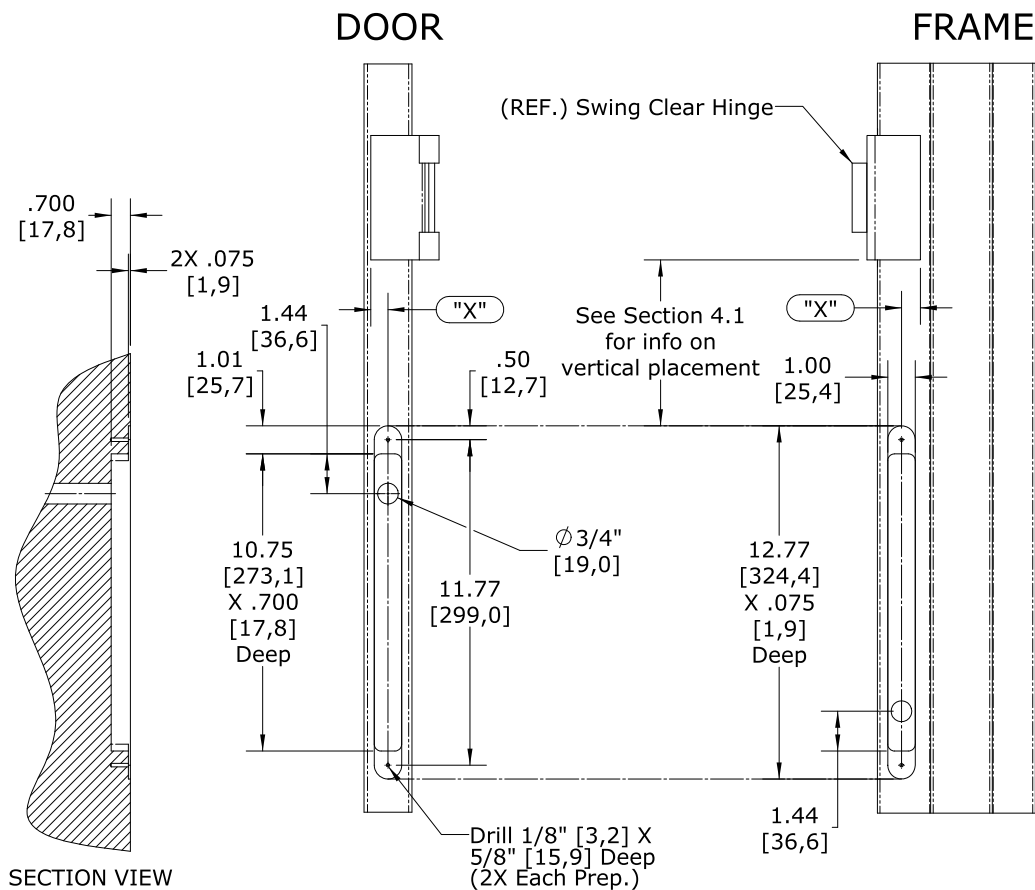

Figure 1 – Wood Door/Frame Prep.

- Using a 1" [25,4mm] diameter bit with the router depth set to .075" [1,9mm], route the two (2) recesses required for the rounded lead cover end flanges.
- One at a time, place each lead cover into its intended position and mark the two (2) mounting hole locations and the cable feed thru (obround) hole location for each cover.

Note: The 3/4" [19,0mm] diameter holes required for the wire feed thru in the door and frame must be positioned at opposing ends with respect to each other. (i.e. if the hole is toward the top of the lead cover to go in the door, then the hole for the wire feed thru of the lead cover in the frame should be at the bottom (see **Figure 1**).

- Drill the (2) two mounting holes for each lead cover using a 1/8" [3,2mm] diameter drill bit. Drill all four (4) holes to a depth of approximately 5/8" [15,9mm].

- Drill a 3/4" [19,0mm] diameter hole into the door to provide routing of the wires to the device being used. Then drill a 3/4" [19,0mm] diameter hole through the frame at the marked locations.

Note: *At this point, if the door was removed, it may be reinstalled.*

Standard Wiring:

- Pass the cable from the exit device being installed through the hole in the door edge.
- Using a screwdriver and the four (4) 8-32 X 3/16" Phillips pan head screws and split ring lock washers (included), assemble the flexible shield to the inside of both of the lead covers as shown in **Figure 4**. Two (2) screws and washers are required at each end.
- Insert the cable through the obround hole in the lead cover, feed through the flexible shield and then out the hole of the other lead cover. Make necessary electrical connections at the appropriate door or frame location.
- Mount each of the lead covers into place using a screwdriver and two (2) of the #6 X 5/8" Phillips flat head type "A" screws provided.

ElectroLynx® Wiring:

- Insert the EL connectors at each end of the flexible shield through the obround holes inside each lead cover.
- Using a screwdriver and the four (4) 8-32 X 3/16" Phillips pan head screws and split ring lock washers (included), assemble the flexible shield to the inside of both of the lead covers as shown in **Figure 4**. Two (2) screws and washers are required at each end.
- Attach the supply wiring EL connectors (from the frame) and the door device wiring EL connectors (from the door) to the appropriate EL connectors of the EL-EPT-SC.
- As necessary, fold and tuck wiring and connectors back into the holes in door and frame.
- Mount each of the lead covers into place using a screwdriver and two (2) of the #6 X 5/8" Phillips flat head type "A" screws provided.

4.4 Metal Doors and Frames:

- Using a router or saw, create the cutout required for the lead cover. The cutout may be cut with a radius (as shown) or square-cornered as noted in **Figure 2**.

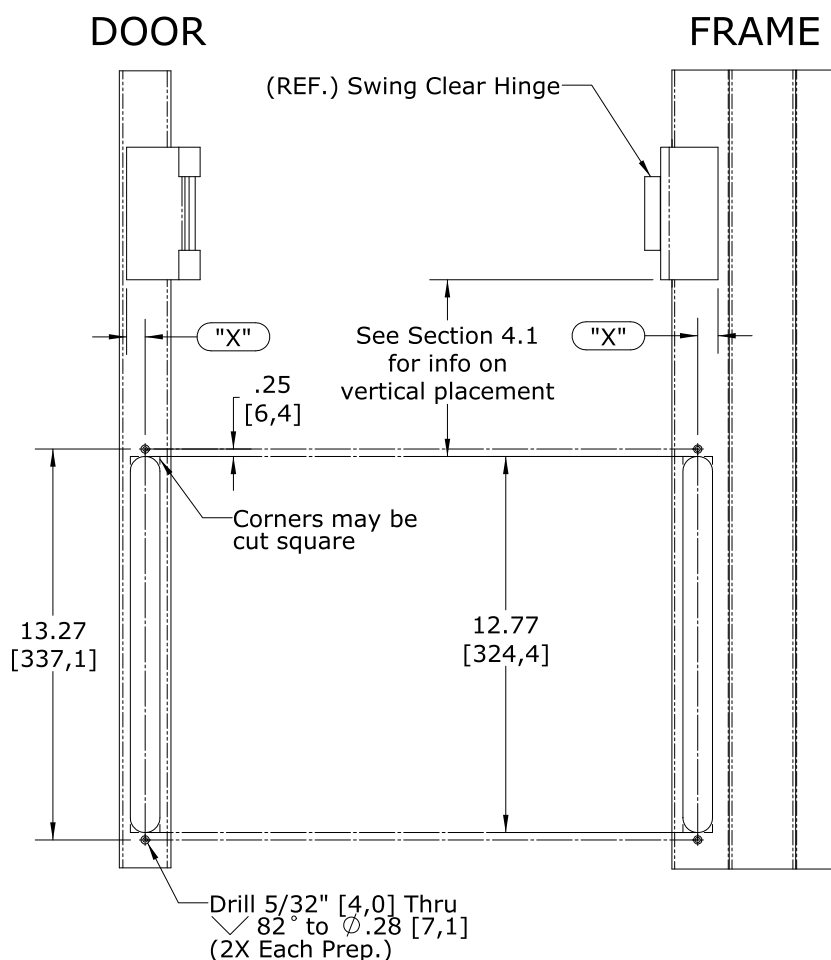

Figure 2 – Metal Door/Frame Prep.

- Mark, drill and countersink the two (2) 5/32" [4,0] diameter flush tab bracket mounting holes at each end of the cutout as shown and directed on the template.

- Insert and install the two (2) flush tab brackets provided using the included 6-32 x 3/8" type "F" (self-tapping) screws.

Note: *At this point, if the door was removed, it may be reinstalled.*

Standard Wiring:

- Pass the cable from the exit device being installed through the hole in the door edge.
- Using a screwdriver and the four (4) 8-32 X 3/16" Phillips pan head screws and split ring lock washers (included), assemble the flexible shield to the inside of both of the lead covers as shown in **Figure 4**. Two (2) screws and washers are required at each end.
- Insert the cable through the obround hole in the lead cover, feed through the flexible shield and then out the hole of the other lead cover. Make necessary electrical connections at the appropriate door or frame location.
- Mount each of the lead covers into place at the previously installed flush tab brackets using a screwdriver and two (2) of the 6-32 X 3/8" type "F" (self-tapping) screws provided.

ElectroLynx® Wiring:

- Insert the EL connectors at each end of the flexible shield through the obround holes inside each lead cover.
- Using a screwdriver and the four (4) 8-32 X 3/16" Phillips pan head screws and split ring lock washers (included), assemble the flexible shield to the inside of both of the lead covers as shown in **Figure 4**. Two (2) screws and washers are required at each end.
- Attach the supply wiring EL connectors (from the frame) and the door device wiring EL connectors (from the door) to the appropriate EL connectors of the EL-EPT-SC.
- Insert wiring and connectors back into holes in door and frame.
- Mount each of the lead covers into place at the previously installed flush tab brackets using a screwdriver and two (2) of the 6-32 X 3/8" type "F" (self-tapping) screws provided.

The **Figure 3** illustration shows exploded views of configurations for both the solid core wood door and hollow metal door installations.

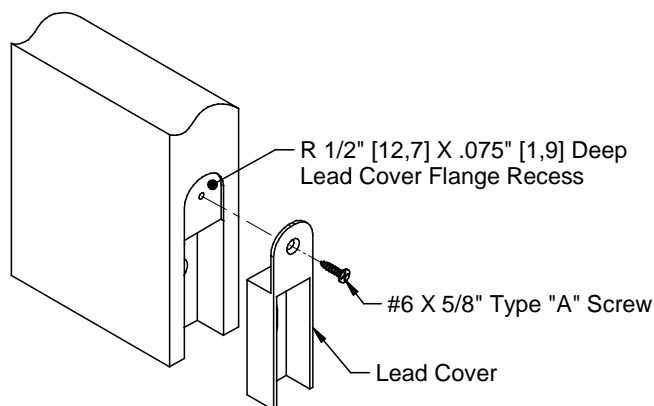

Wood Door Installation

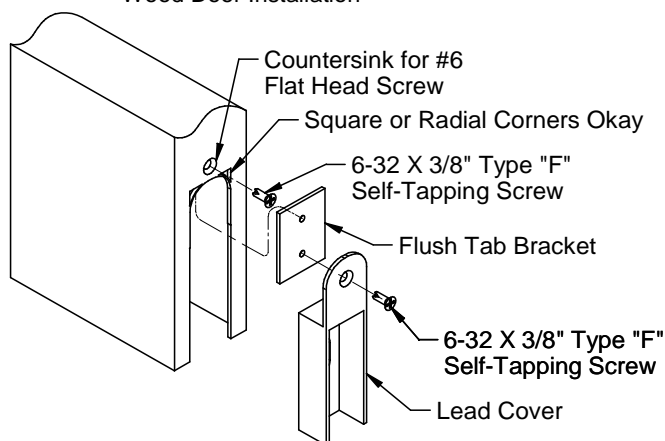

Metal Door Installation

Figure 3

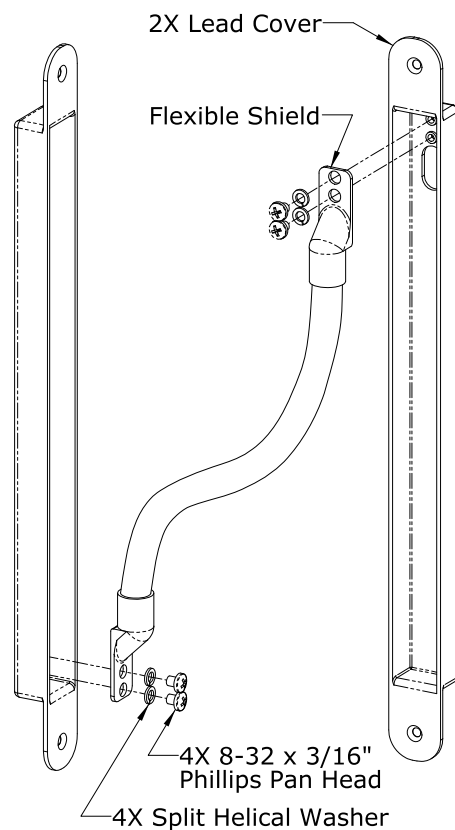

Figure 4

Note: *For applications involving combinations of doors/frames made of wood and metal, follow the proper procedures as related to the door/frame material.*

EPT-SC and EL-EPT-SC Special UL/Electrical Notes:

- *To maintain compliance with UL listings (UL 10C and UBC 7-2-1997), the maximum number of electrical conductors to be used is twelve (12) - using No. 20-22 AWG size wire.*
- *Electrical rating for the EPT-SC and the EL-EPT-SC is 1Amp @ 12V or 24V – AC or DC.*