



EXIT DEVICES

Apex 2000 Series



TABLE OF CONTENTS

WIDE STILE EXIT DEVICES & TRIMS	Page	ACCESSORIES	Page
Rim Devices.....	4, 5	ALK Exit Alarm Kit.....	27
Surface Vertical Rod Devices.....	6, 7	CDK Cylinder Dogging Kit.....	19
Mortise Devices.....	8, 9	E Electric Lock/Unlock Kit.....	28
Wood Door Concealed Vertical Rod Devices.....	14, 15	ELR Conversion Kit.....	21
Concealed Vertical Rod Devices.....	16, 17	ELR150 Power Supply and Modules.....	21,22
NARROW STILE EXIT DEVICES & TRIMS		LSK Latchbolt Monitoring Conversion Kit.....	29
Rim Devices.....	10, 11	PS160-6 Power Supply.....	25
Concealed Vertical Rod Devices.....	12, 13	RPSMLR2 Power Supplies.....	41
MULLIONS		TSK Touchbar Monitoring Conversion Kit.....	29
Removable Mullion.....	18	Cylinders.....	19
Fire Labeled Removable Mullion.....	18	Double Cylinders Conversion Kit.....	19
Key Removable Mullion.....	18	Sex Nuts & Bolts.....	3
EXIT DEVICE OPTIONS		Strikes.....	34
ALK Exit Alarm (Battery Operated).....	27	MISCELLANEOUS COMPONENTS	
ALW Exit Alarm (Remote Power).....	27	Braille Touchbar.....	35
BRL Braille Touchbar.....	35	Dummy Touchbar.....	35
C Quick Connect.....	39	End Cap & Mounting Bracket.....	35
CD Cylinder Dogging.....	19	Dogging Key & Rod Guide.....	35
DE Delayed Egress.....	24, 25	Electrical Power Transfers.....	32
DS Door Position Switch.....	29	Fire Bolt Assembly.....	35
E Electric Rim & Mortise Devices.....	28	Security Screws.....	35
ELR Electric Latch Retraction.....	21, 22, 23	Shim Kit.....	35
HC Windstorm and Hurricane Code Devices.....	20	Top Rod & Bottom Rod lengths.....	35
LD Less Dogging.....	19	ADDITION INFORMATION	
LS Latchbolt Monitoring.....	29	Introduction.....	2
LDS Latchbolt Monitoring Double Switch.....	29	Base Material and Finishes.....	3
MLR Motorized Latch Retraction.....	40, 41	DE Application Charts.....	26
Q Wireless Access Management System.....	30-32	Device Dimensions.....	37
TS Touchbar Monitoring.....	29	Device Minimum Stile Width.....	36, 37
TDS Touchbar Monitoring Double Switch.....	29	ELR application Charts.....	23
WALW Weatherized Exit Alarm (Remote Power).....	27	Fasteners.....	3
WTS Weatherized Touchbar Monitoring.....	29	Fire Label Rating Chart.....	33
WTDS Weatherized Touchbar Mon. Double Switch.....	29	Quiet Operation.....	2
Double Cylinder.....	9	Touchbar Clearance.....	2
Electric Mortise Lock.....	28	Trim Dimensions.....	38

Introduction

The Apex 2000 Series Touchbar Style Exit Device is highly regarded by architects and end-users alike. Many of the nation's largest healthcare and educational facilities prefer the Apex for its aesthetic design and efficient engineering. All Apex 2000 Series Exit Devices are UL listed for panic and fire hardware and are certified to ANSI A156.3 Grade 1. Several models are also certified for hurricane resistant applications.

A complete offering of mechanical and electrical options provide a wide range of exit device security solutions. However, the traditional core strengths of the product can't be overstated. Simple operation with few moving parts, manufactured with true ANSI/BHMA architectural finishes. The chassis is constructed from investment cast steel and the universal mounting holes provide an easier retrofit installation.

Quiet Operation

Sound Dampeners reduce the noise associated with Exit Device operation on the depression and return stroke of the Touchpad.

Touchbar Clearance

The Apex Wide Stile Series Exit Devices accommodate doors with vision lites or glass windows where the vision lite frames or moldings project up to 1/4 beyond the face of the door. The Active Case and End Cap Mounting Bracket are mounted on the face of the door without shims or without cutting the glass molding. These devices have a 1/4" gap between the face of the door and the Touchbar Assembly. This gap allows proper functioning of the devices even on doors which are not perfectly flat. Since the Active Case is mounted directly on the face of the door, it accommodates standard lengths of through bolting screws, thumbpieces, knob & lever Trim fingers, and cylinder tail pieces.

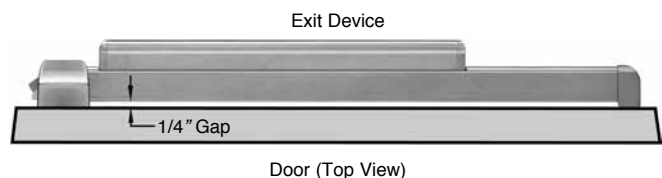

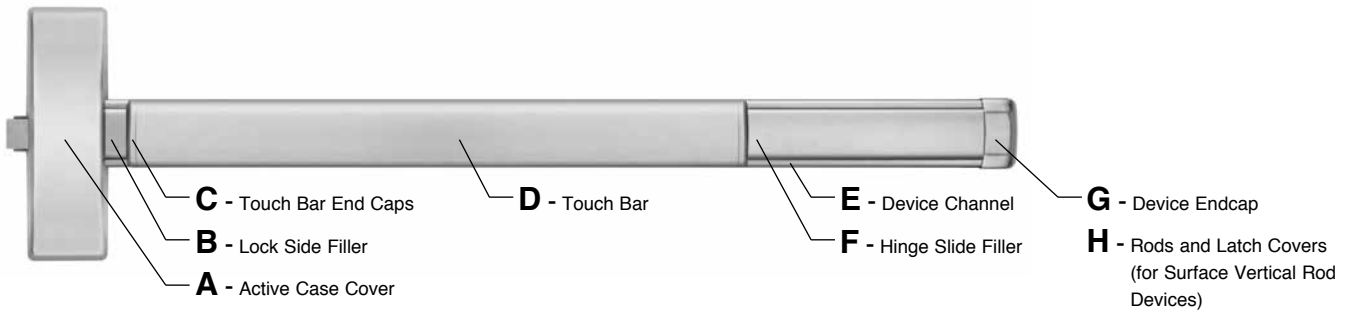

Base Materials

Finishes	ANSI/BHMA	US	Aluminum	Brass	Bronze	Stainless Steel
Polished Brass, Clear Coated	605	US3	—	A,B,C,D,E,F,G,H	—	—
Satin Brass, Clear Coated	606	US4	—	A,B,C,D,E,F,G,H	—	—
Satin Bronze, Clear Coated	612	US10	—	—	A,B,C,D,E,F,G,H	—
Dark Oxidized Satin Bronze	613	US10B	—	—	A,B,C,D,E,F,G,H	—
Satin Aluminum, Clear Anodized	628	US28	A,E,F	—	—	B,C,D,G,H
Satin Chrome, Weatherized	626W	US26D	—	A,B,C,D,E,F,G,H	—	—
Satin Stainless Steel	630	US32D	—	—	—	A,B,C,D,E,F,G,H

Finishes

ANSI/BHMA	US	Description
605	US3	Polished Brass, Clear Coated
606	US4	Satin Brass, Clear Coated
612	US10	Satin Bronze, Clear Coated
613	US10B	Dark Oxidized Satin Bronze
625	US26	Polished Chromium Plated
626W	US26D	Satin Chrome, Weatherized
628	US28	Satin Aluminum, Clear Anodized
630	US32D	Satin Stainless Steel

Mullion finishes

600	USP	Primed for Paint
689		Aluminum Paint
695		Dark Bronze Paint

Fasteners

Furnished standard with machine screws and full thread wood/sheet metal screws. Specify Sex Nuts and Bolts (SNB) where recommended or required by the door manufacturer.

Sex Nuts & Bolts (not furnished std.)

Sex Nuts & Bolts are furnished with No. 10-24 x 1" OHMS (1-1/2" long screws required for guides).

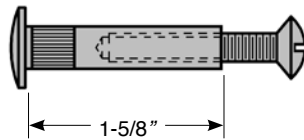

Security Screws

All exposed screws will be a Torx pin in tamper resistant type, machine screws only. Specify (SEC) Security Screws. Cover Screws use a T20 driver, End Cap Screws use a T25 driver.



Door Sizes

Stock sizes for door widths and heights are listed below. If required, cut to size in the field.

Door Widths **Stock Sizes**

2'-0" to 2'-6"	2'-6"*
2'-7" to 3'-0"	3'-0"
3'-1" to 4'-0"	4'-0"

* Not available for Narrow Stile Devices.

Vertical Rod Devices

Device	Door Heights	Stock Sizes
Surface Vertical Rod Device*	up to 7'-0"	7'-0"
	7'-1" to 8'-0"	8'-0"
	8'-1" to 10'-0"	10'-0"
Concealed Vertical Rod Device	6'-8" to 8'-0"	8'-0"
	8'-1" to 10'-0"	10'-0"

* Surface Vertical Rods are furnished of the same material as the device. Stainless steel rods are furnished for 625, 628 and 630 devices.

Hand of Doors

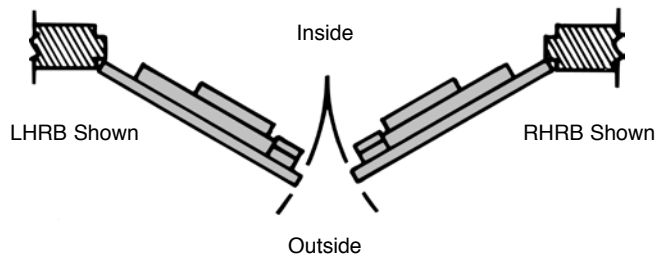

RIM EXIT DEVICES



Apex 2100 Series - Reversible
Apex FL2100 Fire Exit Series - Reversible

DOORS - For all types of single and double doors with a mullion. For mullions, see page 18. Available for 1-3/4" to 2-1/4" thick, up to 4'-0" wide opening. For thicker doors, consult factory. Furnished standard for 1-3/4" thick, 3'-0" wide opening.

DEVICE - Covers ANSI A115.2 (Type 161), A115.18 cylinder lock and A115.1 (Type 86) Mortise Lock preparation.

FUNCTIONS - Functions are field selectable except for the Double Cylinder option. The device is furnished for a desired function if specified. If not specified the "03" function is furnished standard.

DOUBLE CYLINDER - Handed, "10" Function available. Requires two rim type cylinders, not furnished standard. See page 5 and 19.

BASE MATERIAL - The Cover, Touchbar, Device Channel, Lock/Hinge Side Filler and End Cap are furnished of heavy wrought Brass, Bronze or Stainless Steel. 628 Devices are furnished with Aluminum, Brass, Bronze and Stainless Steel components. See "Finish & Base Material" chart page 3.

CHASSIS - Investment Cast Steel, Zinc Dichromated.

LATCHBOLT - Stainless Steel, Deadlocking, 3/4" throw.

STRIKES - No. S300, Investment Cast Stainless Steel, Black Powder Coated furnished standard. No. S988, optional strike for use on Aluminum Door applications, please specify when ordering. No. S458, optional strike for use on Mullion applications, please specify when ordering. For optional strike information see page 34.

DOGGING - 1/4" turn hex key dogging standard. NOT available on Fire Exit Hardware.

TOUCHBAR HEIGHT - 39-15/16" from floor standard. May be varied as situation dictates.

REVERSIBLE - Reversible for all functions and Trims. Standard packaging RHRB.

UL LISTED - Panic and Fire Exit Hardware. For FIRE EXIT HARDWARE Ratings see page 33. Conforms to UL10C and UBC 7-2.

ANSI/BHMA - Devices are BHMA certified for ANSI 156.3, Grade 1.

FINISHES - 605, 606, 612, 613, 625, 626W, 628, 630. For Finish description see page 3.

CYLINDERS - Rim Type, not furnished standard. Specify when required. For cylinder details see page 19.

STILE WIDTH - See Stile Information on page 36.

RETROFIT APPLICATIONS - The 2100 and FL2100 Series Devices are designed to retrofit into other manufacturers' mounting hole locations. 1700 Series Pull Trim and 4900 Series Lever Trim may also be factory set for these applications by specifying prefix "R" (e.g. 2108 R4908A). Consult factory for details.

Apex 21 Series - Nonhanded

The 21 Series Device is designed to be compatible with many manufacturers' Access Control exterior trim. The device incorporates a center driven cam to receive the tailpiece of the access control product. The tailpiece rotation required to retract the latch is a minimum of 50 degrees.

Consult factory for details.

DEVICE OPTIONS

Prefix	Description	Page
C	Quick Connect Plugs.....	39
DE	Delayed Egress.....	24
E	Electric Device	28
ELR	Electric Latch Retraction	21
FL	Fire Exit Hardware	4
HC	Windstorm and Hurricane Code Device	20
LDS	Latchbolt Monitoring Double Switch	29
LS	Latchbolt Monitoring Switch	29
MLR	Motorized Latch Retraction	40-41
Q	Wireless Access Management System.....	30-32
TDS	Touchbar Monitoring Double Switch	29
TS	Touchbar Monitoring Switch.....	29
WTDS	Weatherized Touchbar Mon. Dbl. Switch.....	29
WTS	Weatherized Touchbar Monitoring Switch	29

To specify add Prefix to Device No. (e.g. TS2103)

Suffix	Description	Page
ALK	Exit Alarm: battery operated	27
ALW	Exit Alarm: remote power	27
BRL	Braille Touchbar	35
CD	Cylinder Dogging	19
DS	Door Position Monitoring Switch.....	29
LD	Less Dogging	19
SEC	Security Screws	3
SNB	Sex Nut and Bolt.....	3
WALW	Weatherized Exit Alarm: remote power	27

To specify add Suffix to Device No. (e.g. 2103CD)

1700A
"A" Grip



1700B
"B" Grip



1700C
"C" Grip



2000C
"C" Grip



1. All Trims are furnished with wrought plates and extruded or cast solid grips.
2. Specify Grip Design (A,B,C) ("A" Grip furnished standard for 1700 Series Trim, "C" Grip furnished standard for 2000 Series Trim)
3. 630 Trim is furnished for 628 Devices.
4. 626 Trim is furnished for 626W Devices.

Retrofit Applications

The R1700 Series Trim is designed to retrofit into other manufacturers' installations when used with the wide stile Apex Series Devices.

Consult factory for details.

4900A
"A" Lever



4900B
"B" Lever



4900C
"C" Lever



4900D
"D" Lever



4900K
"K" Knob



V4908A
Vandal Resistant Trim

A heavy duty lever trim designed to with stand abuse and vandalism. Composed of extra strength shock-absorbing "overload" springs and heavy duty investment cast stainless steel internal components. Lever returns to the "home" position eliminating the need to reset the lever.

Retrofit Applications

The R4900 Series Trim is designed to retrofit into other manufacturers' installations when used with the wide stile Apex Series Devices.

Consult factory for details.

1. All the escutcheons and levers are castings or forgings.
2. Specify Lever or Knob Design (A,B,C,D,K) and Handing ("A" Lever x RHRB furnished standard)
3. 626 Trim furnished for 626W, 628 and 630 Devices.
 - For Trim dimensions see page 38.
 - Trims are BHMA certified for ANSI 156.3, Grade 1.
 - Trims are through bolted and will cover 161 and 86 cutouts (except for 2000C Trim).
 - Cylinder, Rim Type, not furnished standard. For cylinder details see page 19.

ANSI Function	01	02	03	05	08	10*	14	15
	Exit Only (cover plate)	Dummy Trim	Key Retracts Latchbolt	Key Locks/Unlocks Thumbpiece	Key Locks/Unlocks Lever/Knob	Double Cylinder Inside Key Locks/Unlocks Lever/Knob	No Cylinder Lever/Knob Always Active	No Cylinder Thumbpiece Always Active
Device Nos.	2101 FL2101	2102	2103** FL2103**	2105 FL2105	2108 FL2108	2110 FL2110	2114 FL2114	2115 FL2115
Trim Nos.	1701 R1701	1702A R1702A	1703A R1703A	1705A R1705A	4908A V4908A	4908A V4908A	4914A R4914A	1715A R1715A
	2001	2002C	2003C	2005C	R4908A	R4908A		2015C
	4901	4902A	4903A		RV4908A	RV4908A		
	R4901	R4902A	R4903A					

Device with Trim:

Device No. _____

Add **Prefix** for options, see page 4.

Add **Suffix**: for options, see page 4.

Add **Prefix**: "V" Vandal Resistant Lever Trim
"R" Retrofit Trim

Add **Suffix**: Lever or Knob Design (A,B,C,D, K)
Grip Design (A,B,C)

Add **Suffix**: "KNR" Knurled Lever or Grip

TS2108CD x V4908AKNR x RHRB x 630 x S300 x 3'-0" x 7'-0" x 1-3/4"

Device w/options

Trim No.

Hand

Finish

Strike

Door Size

Device Only: Device no., hand, finish, strike, and door size including thickness:
(e.g. TS2108CD x RHRB x 630 x S300 x 3'-0" x 7'-0" x 1-3/4")

Trim Only: Trim no., hand, finish, strike, and door size including thickness: (e.g. V4908A x RHRB x 626 x 1-3/4")

* "10" Function is handed

** 2103 & FL2103 x Cylinder Only Application includes Cylinder Attachment Kit "CA-03"

SURFACE VERTICAL ROD EXIT DEVICES



Apex 2200 Series - Reversible

Apex FL2200 Fire Exit Series - Reversible

S300

DOORS - For all types of single and double door applications. Available for 1-3/4" to 2-1/4" thick, up to 4'-0" wide by 10'-0" high openings. For thicker doors, consult factory. Furnished standard for 1-3/4" thick, 3'-0" wide by 7'-0" high openings.

DEVICE - Covers ANSI A115.2 (Type 161), A115.18 cylinder lock and A115.1 (Type 86) Mortise Lock preparation.

FUNCTIONS - Functions are field selectable. The device is furnished for a desired function if specified. If not specified the "03" function is furnished standard.

BASE MATERIAL - The Covers, Touchbar, Device Channel, Lock/Hinge Side Filler, Vertical Rods and End Cap are furnished of heavy wrought Brass, Bronze or Stainless Steel. US28 Devices are furnished with Aluminum, Brass, Bronze and Stainless Steel components. See "Finish & Base Material" chart on page 3.

CHASSIS - Investment Cast Steel, Zinc Dichromated.

TOP LATCHBOLT - Stainless Steel, Deadlocking, 3/4" throw.

BOTTOM BOLT - Steel plated, independent action 5/8" throw, with adjustment range to suit 3/4" door undercut.

TOP STRIKE - No. S300 Surface applied, Investment Cast Stainless Steel, Black Powder Coated furnished standard. For optional strikes see page 34.

BOTTOM STRIKE - No. S460, Flush mounted, Steel, Black Powder Coated.

DOGGING - 1/4" turn hex key dogging standard. NOT available on Fire Exit Hardware.

TOUCHBAR HEIGHT - 39-15/16" from floor standard. Specify required height if other than standard.

DEVICE OPTIONS

Prefix	Description	Page
C	Quick Connect Plugs	39
E	Electric Device	28
ELR	Electric Latch Retraction	21
FL	Fire Exit Hardware	6
HC	Windstorm and Hurricane Code Device	20
LS	Latchbolt Monitoring Switch	29
MLR	Motorized Latch Retraction	40-41
Q	Wireless Access Management System	30-32
TDS	Touchbar Monitoring Double Switch	29
TS	Touchbar Monitoring Switch	29
WTDS	Weatherized Touchbar Mon. Dbl Switch	29
WTS	Weatherized Touchbar Mon. Switch	29

To specify add Prefix to Device No. (e.g. TS2203)

REVERSIBLE - Reversible for all functions and trims. Standard packing RHRB.

UL LISTED - Panic and Fire Exit Hardware. For FIRE EXIT HARDWARE Ratings see page 33. Conforms to UL10C and UBC 7-2.

ANSI/BHMA - Devices are BHMA certified ANSI 156.3, Grade 1.

FINISHES - 605, 606, 612, 613, 625, 626W, 628, 630. For finish description see page 3.

CYLINDERS - Rim type, not furnished standard. Specify when required. For cylinder details see page 19.

STILE WIDTH - See Stile Information on page 36.

LESS BOTTOM ROD (LBR) OPTION - Specify suffix "LBR" (e.g. 2208LBR). See UL FIRE LABEL RATING chart on page 39. Fire Rated Devices include FB277 Fire Bolt Assembly. For Fire Bolt Assembly image see page 35.

RETROFIT APPLICATIONS - The 2200 and FL2200 Series Devices are designed to retrofit into other manufacturers' mounting hole locations. 1700 Serie Pull Trim and 4900 Series Lever Trim may also be factory set for these applications by specifying prefix "R" (e.g. 2208 R4908A).

Apex 22 Series - Reversible

The 22 Series Device is designed to be compatible with many manufacturers' Access Control exterior trim. The device incorporates a center driven cam to receive the tailpiece of the access control product. The tailpiece rotation required to retract the latch is a minimum of 50 degrees.

Consult factory for details.

Suffix	Description	Page
ALK	Exit Alarm: battery operated	27
ALW	Exit Alarm: remote power	27
BRL	Braille Touchbar	35
CD	Cylinder Dogging	19
DS	Door Position Monitoring Switch	29
LBR	Less Bottom Rod	6
LD	Less Dogging	19
SEC	Security Screws	3
SNB	Sex Nut and Bolt	3
TMB	Transom Bracket	35
WALW	Weatherized Exit Alarm: remote power	27

To specify add Prefix to Device No. (e.g. TS2203)



S460

1700A
"A" Grip



1700B
"B" Grip



1700C
"C" Grip



2000C
"C" Grip



1. All Trims are furnished with wrought plates and extruded or cast solid grips.
2. Specify Grip Design (A,B,C) ("A" Grip furnished standard for 1700 Series Trim, "C" Grip furnished standard for 2000 Series Trim)
3. 630 Trim is furnished for 628 Devices.
4. 626 Trim is furnished for 626W Devices.

Retrofit Applications

The R1700 Series Trim is designed to retrofit into other manufacturers' installations when used with the wide stile Apex Series Devices.

Consult factory for details.

4900A
"A" Lever



4900B
"B" Lever



4900C
"C" Lever



4900D
"D" Lever



4900K
"K" Knob



V4908A
Vandal Resistant Trim

A heavy duty lever trim designed to with stand abuse and vandalism. Composed of extra strength shock-absorbing "overload" springs and heavy duty investment cast stainless steel internal components. Lever returns to the "home" position eliminating the need to reset the lever.

Retrofit Applications

The R4900 Series Trim is designed to retrofit into other manufacturers' installations when used with the wide stile Apex Series Devices.

Consult factory for details.

1. All the escutcheons and levers are castings or forgings.
2. Specify Lever or Knob Design (A,B,C,D,K) and Handing ("A" Lever x RHRB furnished standard)
3. 626 Trim furnished for 626W, 628 and 630 Devices.

- For Trim dimensions see page 38.
- Trims are BHMA certified for ANSI 156.3, Grade 1.
- Trims are through bolted and will cover 161 and 86 cutouts (except for 2000C Trim).
- Cylinder, Rim Type, not furnished standard. For cylinder details see page 19.

ANSI Function	01 Exit Only (cover plate)	02 Dummy Trim	03 Key Retracts Latchbolt	05 Key Locks/Unlocks Thumbpiece	08 Key Locks/Unlocks Lever/Knob	14 No Cylinder Lever/Knob Always Active	15 No Cylinder Thumbpiece Always Active
Device Nos.	2201 FL2201	2202	2203** FL2203**	2205 FL2205	2208 FL2208	2214 FL2214	2215 FL2215
Trim Nos.	1701 R1701 2001 4901 R4901	1702A R1702A 2002C 4902A R4902A	1703A R1703A 2003C 4903A R4903A	1705A R1705A 2005C	4908A V4908A R4908A RV4908A	4914A R4914A	1715A R1715A 2015C

Device with Trim:

Device No. _____

Add Prefix for options, see page 6.

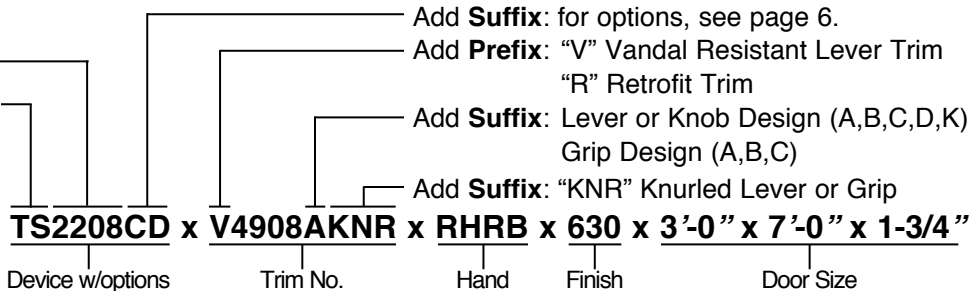

Device Only: Device no., hand, finish, strike, and door size including thickness:
(e.g. TS2208CD x RHRB x 630 x 3'-0" x 7'-0" x 1-3/4")

Trim Only: Trim no., hand, finish, strike, and door size including thickness: (e.g. V4908A x RHRB x 626 x 1-3/4")

* 2203 & FL2203 x Cylinder Only Application includes Cylinder Attachment Kit "CA-03"

MORTISE EXIT DEVICES



Apex 2300 Series - Handed

Apex FL2300 Fire Exit Series - Handed

DOORS - For all types of single and double door applications. Available for 1-3/4" to 2-1/4" thick, up to 4-0" wide opening. For thicker door, consult factory. Furnished standard for 1-3/4" thick, 3'-0" wide opening.

DEVICE - Covers ANSI A115.1 (Type 86) Mortise Lock preparation.

DOUBLE CYLINDER - Handed, "10" Function available. Requires one rim type cylinder and one 1-1/4" long mortise type cylinder, not furnished standard. See page 9 and 19.

BASE MATERIAL - The Cover, Touchbar, Device Channel, Lock/Hinge Side Filler and End Cap are furnished of heavy wrought Brass, Bronze or Stainless Steel. US28 Devices are furnished with Aluminum, Brass, Bronze and Stainless Steel components. See "Finish & Base Material" chart on page 3.

CHASSIS - Investment Cast Steel, Zinc Dichromated.

DOGGING - 1/4" turn hex key dogging standard. NOT available on Fire Exit Hardware.

TOUCHBAR HEIGHT - 39-15/16" from floor standard.

HANDED - Specify hand when ordering as RHRB or LHRB. Touchbar Assembly, Mortise Lock and Trim may be reversed in the field. For reversibility of complete device, mortise strike is required for the other hand.

UL LISTED - Panic and Fire Exit Hardware. For FIRE EXIT HARDWARE Ratings see page 33. Conforms to UL10C and UBC 7-2.

ANSI/BHMA - Devices are BHMA certified for ANSI 156.3, Grade 1.

FINISHES - 605, 606, 612, 613, 625, 626W, 628, 630. For finish description see page 3.

STILE WIDTH - See Stile Information on page 36.

CYLINDERS - Mortise type, not furnished standard. For cylinder details see page 19.

RETROFIT APPLICATIONS - The 2300 and FL2300 Series Devices are designed to retrofit into other manufacturers' mounting hole locations. 1700 Series Pull Trim and 4900 Series Lever Trim may also be factory set for these applications by specifying prefix "R" (e.g. 2308 R4908A).

Consult factory for details.

Exit Series - Handed

Fits doors machined per ANSI A115.1 (Type 86) Mortise Lock preparation.

BACKSET - 2-3/4".

CASE - Wrought Steel, Zinc Dichromate finish.

LOCK FRONT PLATE - 8" x 1-1/4" Bronze, Brass or Stainless Steel, pivots for beveled or square edged doors.

LATCHBOLT - Stainless Steel, Deadlocking, 3/4" throw, anti-friction.

GUARDBOLT - Stainless Steel, sliding type.

FINISHES - LOCK FRONT PLATE and STRIKE
605, 606, 612, 613, 625, 630. 630 furnished for 626 and 628 locks. For finish description see page 3.

STRIKES - No. S982, handed curved lip strike furnished standard. For optional strikes see page 34.

LOCK NO.

- M303: 01, 02 & 03 functions.
- M308: 05, 08, 14 & 15 functions.
- M310: 10 function.

NOTE - For Mortise Lock dimensions see page 28.
For Mortise Lock with Electrical options see page 28.

DEVICE OPTIONS

Prefix	Description	Page
C	Quick Connect Plugs.....	39
DE	Delayed Egress	24
E	Electric Lock/Unlock	28
ELR	Electric Latch Retraction.....	21
FL	Fire Exit Hardware.....	8
HC	Windstorm and Hurricane Code Device	20
LS	Auxiliary Latchbolt Monitoring, "03" Function.....	28, 29
LS	Latchbolt and Trim locked or unlocked monitoring, "08" Function.....	28, 29
MLR	Motorized Latch Retraction.....	40-41
TDS	Touchbar Monitoring Double Switch.....	29
TS	Touchbar Monitoring Switch	29

Prefix	Description	Page
WTDS	Weatherized Touchbar Mon. Dbl. Switch.....	29
WTS	Weatherized Touchbar Monitoring Switch	29
Suffix	Description	Page
ALK	Exit Alarm: battery operated	27
ALW	Exit Alarm: remote power.....	27
BRL	Braille Touchbar	35
CD	Cylinder Dogging.....	19
DS	Door Position Monitoring Switch	29
LD	Less Dogging	19
SEC	Security Screws	3
SNB	Sex Nut and Bolt	3
WALW	Weatherized Exit Alarm: remote power	27

To specify add Suffix to Device No. (e.g. 2303CD)

To specify add Prefix to Device No. (e.g. TS2303)

1700A
"A" Grip



1700B
"B" Grip



1700C
"C" Grip



2000C
"C" Grip



1. All Trims are furnished with wrought plates and extruded or cast solid grips.
2. Specify Grip Design (A,B,C) ("A" Grip furnished standard for 1700 Series Trim, "C" Grip furnished standard for 2000 Series Trim)
3. 630 Trim is furnished for 628 Devices.
4. 626 Trim is furnished for 626W Devices.

NOTE: B & C grip pull handles are not available in the 05 and 15 functions.

Retrofit Applications

The R1700 Series Trim is designed to retrofit into other manufacturers' installations when used with the wide stile Apex Series Devices.

Consult factory for details.

4900A
"A" Lever



4900B
"B" Lever



4900C
"C" Lever



4900D
"D" Lever



4900K
"K" Knob



V4908A

Vandal Resistant Trim

A heavy duty lever trim designed to withstand abuse and vandalism. Composed of extra strength shock-absorbing "overload" springs and heavy duty investment cast stainless steel internal components. Lever returns to the "home" position eliminating the need to reset the lever.

Retrofit Applications

The R4900 Series Trim is designed to retrofit into other manufacturers' installations when used with the wide stile Apex Series Devices.

Consult factory for details.

1. All the escutcheons and levers are castings or forgings.
2. Specify Lever or Knob Design (A,B,C,D,K) and Handing ("A" Lever x RHRB furnished standard)
3. 626 Trim furnished for 626W, 628 and 630 Devices.
4. All Lever Trims, M4908K and M4914K are Handed, Specify Hand.
 - For Trim dimensions see page 38.
 - Trims are BHMA certified for ANSI 156.3, Grade 1.
 - Trims are through bolted and will cover 161 and 86 cutouts (except for 2000C Trim).
 - Cylinder 1-1/4" long Mortise Type, not furnished standard. For cylinder details see page 19.

ANSI Function	01 Exit Only (cover plate)	02 Dummy Trim	03 Key Retracts Latchbolt	05 Key Locks/Unlocks Thumbpiece	08 Key Locks/Unlocks Lever/Knob	10* Double Cylinder Inside Key Locks/Unlocks Lever/Knob	14 No Cylinder Lever/Knob Always Active	15 No Cylinder Thumbpiece Always Active
Device Nos.	2301 FL2301	2302	2303** FL2303**	2305 FL2305	2308 FL2308	2310 FL2310	2314 FL2314	2315 FL2315
Trim Nos.	1701 R1701 2001 4901 R4901	1702A R1702A 2002C 4902A R4902A	1703A R1703A 2003C 4903A R4903A	M1705A RM1705A	M4908A VM4908A RM4908A VRM4908A	M4908A VM4908A RM4908A VRM4908A	M4914A RM4914A	M1715A RM1715A

Device with Trim:

Device No.

Add Prefix for options, see page 8.

Add Suffix: for options, see page 8.

Add Prefix: "V" Vandal Resistant Lever Trim

"M" Mortise Trim (per specific function, see above)

"R" Retrofit Trim

Add Suffix: Lever or Knob Design (A,B,C,D,K)
Grip Design (A,B,C)

Add Suffix: "KNR" Knurled Lever or Grip

TS2308CD x V4908AKNR x RHRB x 630 x S982 x 3'-0" x 7'-0" x 1-3/4"

Device w/options

Trim No.

Hand

Finish

Strike

Door Size

Device Only: Device no., hand, finish, strike, and door size including thickness:

(e.g. TS2108CD x RHRB x 630 x S982 x 3'-0" x 7'-0" x 1-3/4")

Trim Only: Trim no., hand, finish, strike, and door size including thickness: (e.g. VM4908A x RHRB x 626 x 1-3/4")

RIM EXIT DEVICES



S458
Optional for Hollow Metal Door or Mullion applications

Apex 2400 Series - Non Handed
Apex FL2400 Fire Exit Series - Non Handed

DOORS - For all types of single and double doors with a mullion. For mullions, see page 18. Available for 1-3/4" to 2-1/4" thick, up to 4'-0" wide opening. For thicker door, consult factory. Furnished standard for 1-3/4" thick, 3'-0" wide opening.

FUNCTIONS - A Universal Exit Device. Add Trim for desired function.

BASE MATERIAL - The Cover, Touchbar, Device Channel, Lock/Hinge Side Filler and End Cap are furnished of heavy wrought Brass, Bronze or Stainless Steel. US28 Devices are furnished with Aluminum, Brass, Bronze and Stainless Steel components. See "Finish & Base Material" chart on page 3.

CHASSIS - Investment Cast Steel, Zinc Dichromated.

LATCHBOLT - Stainless Steel, Deadlocking, 3/4" throw.

STRIKES - No. S988, standard package for Aluminum Door applications, Black Powder Coated Stainless Steel Roller Strike. No. S458, optional for Hollow Metal Door or Mullion applications, please specify when ordering. For optional strike information see page 34.

DOGGING - 1/4" turn hex key dogging standard. NOT available on Fire Exit Hardware.

TOUCHBAR HEIGHT - 39-15/16" from floor standard. May be varied as situation dictates.

UL LISTED - Panic and Fire Exit Hardware. For FIRE EXIT HARDWARE Ratings see page 33. Conforms to UL10C and UBC 7-2.

ANSI/BHMA - Devices are BHMA certified for ANSI 156.3, Grade 1.

FINISHES - 605, 606, 612, 613, 625, 626W, 628, 630. For finish description see page 3.

CYLINDERS - Rim Type for "03" function, Mortise type for "08" function. Use 1-1/4" long standard mortise cylinder. Cylinders are not furnished standard. Specify when required. For cylinder details see page 19.

STILE WIDTH - See Stile Information on page 37.

DEVICE OPTIONS

Prefix	Description	Page
C	Quick Connect Plugs.....	39
DE	Delayed Egress.....	24
ELR	Electric Latch Retraction	21
FL	Fire Exit Hardware	10
MLR	Motorized Latch Retraction	40-41
TDS	Touchbar Monitoring Double Switch	29
TS	Touchbar Monitoring Switch.....	29
WTDS	Weatherized Touchbar Mon. Dbl. Switch.....	29
WTS	Weatherized Touchbar Monitoring Switch	29

To specify add Prefix to Device No. (e.g. TS2403)

Suffix	Description	Page
ALK	Exit Alarm: battery operated	27
ALW	Exit Alarm: remote power.....	27
BRL	Braille Touchbar	35
CD	Cylinder Dogging.....	19
DS	Door Position Monitoring Switch	29
LD	Less Dogging	19
SEC	Security Screws	3
SNB	Sex Nut and Bolt.....	3
WALW	Weatherized Exit Alarm: remote power	27

To specify add Suffix to Device No. (e.g. 2403CD)



1. All the escutcheons and levers are castings or forgings.
2. For Lever Trim specify Lever Design (A, B, C, D) and Handing ("A" Lever RHRB furnished standard).
3. For 2900 Series Trim, 626 finish is furnished for 628 and 630 Devices.
4. 2000 Series Trim is furnished with a wrought plate and extruded solid "C" Grip.

- For Trim dimensions see page 38.
- Trims are BHMA certified for ANSI 156.3, Grade 1.
- Trims are through bolted.
- Cylinder, not furnished standard – Rim type for "03" function, 1-1/4" long mortise type for "08" function. For cylinder details see page 19.

ANSI Function	01 Exit Only (cover plate)	02 Dummy Trim	03 Key Retracts Latchbolt	08 Key Locks/Unlocks Lever	14 No Cylinder Lever Always Active
Device Nos.	2401 FL2401	2402	2403* FL2403*	2408 FL2408	2414 FL2414
Trim Nos.	2901 2001	2902A 2002C	2903A 2003C	2908A	2914A

Device with Trim:

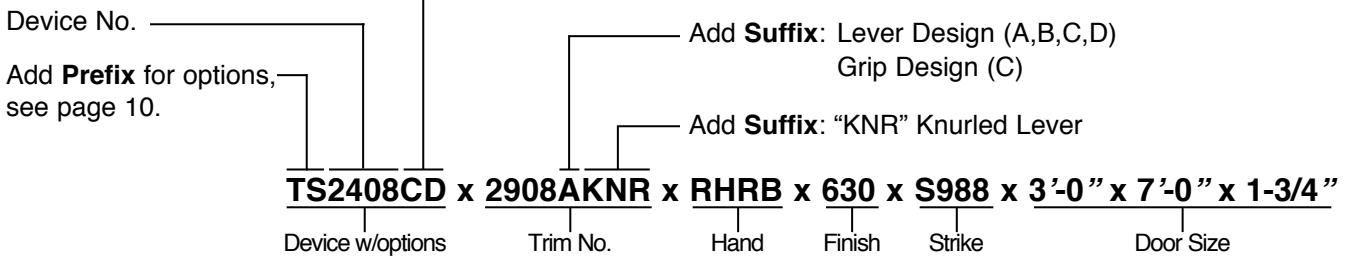

Device Only: Device no., hand, finish, strike, and door size including thickness:
(e.g. TS2408CD x RHRB x 630 x S988 x 3'-0" x 7'-0" x 1-3/4")

Trim Only: Trim no., hand, finish, strike, and door size including thickness: (e.g. 2908A x RHRB x 626 x 1-3/4")

* 2403 & FL2403 x Cylinder Only Application includes Cylinder Attachment Kit "NCA-03"

NARROW CONCEALED VERTICAL ROD EXIT DEVICES

S519



Apex 2600 Series - Reversible
Apex FL2600 Fire Exit Series - Reversible

DOORS - For all types of metal single and double door applications. Available for 1-3/4" to 2-1/4" thick, up to 4'-0" wide by 10'-0" high openings. For thicker doors, consult factory. Furnished standard for 1-3/4" thick, 3'-0" wide by 6'-8" to 8'-0" high openings.

FUNCTIONS - A Universal Exit Device. Add Trim for desired function.

BASE MATERIAL - Side Filler and End Cap are furnished of heavy wrought Brass, Bronze or Stainless Steel. 628 Devices are furnished with Aluminum, Brass, Bronze and Stainless Steel components. See "Finish & Base Material" chart on page 3.

CHASSIS - Lock Stile Assembly - Investment Cast Steel, Zinc Dich-romated.

TOP LATCHBOLT - Stainless Steel, Deadlocking, 3/4" throw.

TOP STRIKE - No. S519 Surface applied, Investment Cast Stainless Steel, Black Powder Coated.

BOTTOM STRIKE - No. S460, Flush mounted, Steel, Black Powder Coated.

DOGGING - 1/4" turn hex key dogging standard. NOT available on Fire Exit Hardware.

TOUCHBAR HEIGHT - 39-15/16" from floor standard. Specify required height if other than standard.

UL LISTED - Panic and Fire Exit Hardware. For FIRE EXIT HARDWARE Ratings see page 33. Conforms to UL10C and UBC 7-2.

ANSI/BHMA - Devices are BHMA certified for ANSI 156.3, Grade 1.

FINISHES - 605, 626, 612, 613, 625, 626W, 628, 630. For finish description see page 3.

CYLINDERS - Rim Type for "03" function, 1-1/4" Long Mortise Type for "08" function. Cylinders are not furnished standard. Specify when required. For cylinder details see page 19.

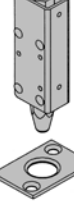
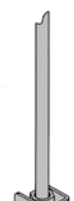
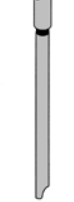
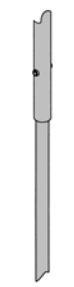

S460



BOTTOM BOLT - Steel plated, independent action 5/8" throw, with adjustment range to suit 3/4" door undercut.

CENTER CHASSIS - Steel plated, heavy wrought Steel Assembly with lock in place Top and Bottom Latch Adjustors. Adjustment is accessible through the door after installation.

STILE WIDTH - See Stile Information on page 37.

LESS BOTTOM ROD (LBR) OPTION - Specify suffix "LBR" (e.g. 2603LBR). See UL FIRE LABEL RATING Chart on page 33. Fire Rated Devices include FB277 Fire Bolt Assembly. For Fire Bolt Assembly image see page 35.

DEVICE OPTIONS

Prefix	Description	Page	Suffix	Description	Page
C	Quick Connect Plugs	39	ALK	Exit Alarm: battery operated	27
DE	Delayed Egress	24	ALW	Exit Alarm: remote power	27
ELR	Electric Latch Retraction	21	BRL	Braille Touchbar	35
FL	Fire Exit Hardware	12	CD	Cylinder Dogging	19
TDS	Touchbar Monitoring Double Switch	29	DS	Door Position Monitoring Switch	29
TS	Touchbar Monitoring Switch	29	LBR	Less Bottom Rod	12
WTDS	Weatherized Touchbar Mon. Dbl. Switch	29	LD	Less Dogging	19
WTS	Weatherized Touchbar Mon. Switch	29	MLR	Motorized Latch Retraction	40-41
To specify add Prefix to Device No. (e.g. TS2603)			SEC	Security Screws	3
			SNB	Sex Nut and Bolt	3
			WALW	Weatherized Exit Alarm: remote power	27
			To specify add Prefix to Device No. (e.g. TS2603)		



1. All the escutcheons and levers are castings or forgings.
2. Specify Lever Design (A, B, C, D) and Handing ("A" Lever RHRB furnished standard).
3. 626 finish is furnished for 628 and 630 Devices.

- For Trim dimensions see page 38.
- Trims are BHMA certified for ANSI 156.3, Grade 1.
- Trims are through bolted.
- Cylinder, not furnished standard – Rim type for "03" function, 1-1/4" long mortise type for "08" function. For cylinder details see page 19.

ANSI Function	01 Exit Only (cover plate)	02 Dummy Trim	03 Key Retracts Latchbolt	08 Key Locks/Unlocks Lever	14 No Cylinder Lever Always Active
Device Nos.	2601 FL2601	2602	2603* FL2603*	2608 FL2608	2614 FL2614
Trim Nos.	2901	2902A	2903A	2908A	2914A

Device with Trim:

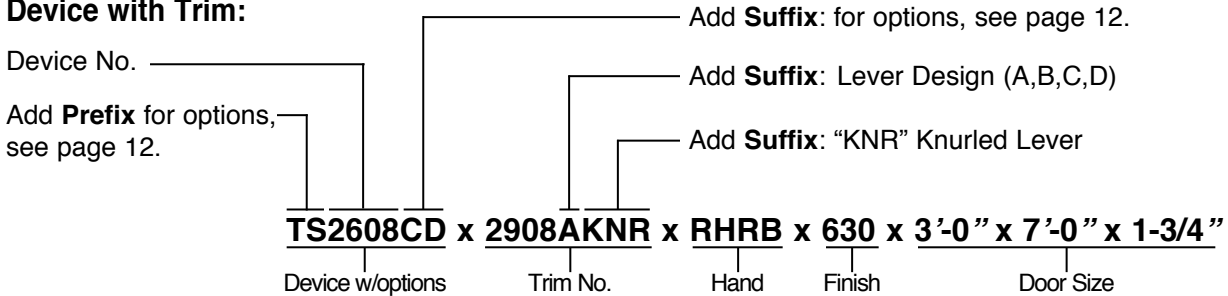

Device Only: Device no., hand, finish, strike, and door size including thickness:
(e.g. TS2608CD x RHRB x 630 x 3'-0" x 7'-0" x 1-3/4")

Trim Only: Trim no., hand, finish, strike, and door size including thickness: (e.g. 2908A x RHRB x 626 x 1-3/4")

* 2603 & FL2603 x Cylinder Only Application includes Cylinder Attachment Kit "NCA-03"

WOOD DOOR CONCEALED VERTICAL ROD EXIT DEVICES

S519

Apex 2700 Series - Reversible Apex FL2700 Fire Exit Series - Reversible

DOORS - For all types of single and double door applications. Available for 1-3/4" to 2-1/4" thick, up to 4'-0" wide by 10'-0" high openings. For thicker doors, consult factory. Furnished standard for 1-3/4" thick, 3'-0" wide by 6'-8" to 8'-0" high openings.

FUNCTIONS - A Universal Exit Device. Add Trim for desired function.

BASE MATERIAL - Side Filler and End Cap are furnished of heavy wrought Brass, Bronze or Stainless Steel. 628 Devices are furnished with Aluminum, Brass, Bronze and Stainless Steel components. See "Finish & Base Material" chart on page 3.

CHASSIS - Lock Stile Assembly - Investment Cast Steel, Zinc Dich-romated.

VERTICAL RODS - Steel, plated. Top Rod is adjustable from 6'-8" to 8'-0" or from 8'-1" to 10'-0". Additional adjustments are available through the lock front filler.

BOTTOM STRIKE - No. S460 Flush mounted, Steel, Black Powder Coated.

DOGGING - 1/4 turn hex key dogging standard. NOT available on Fire Exit Hardware.

TOUCHBAR HEIGHT - 39-15/16 from floor standard. Specify required height if other than standard.

REVERSIBLE - Reversible for all functions and trims. Standard packaging RHRB.

UL LISTED - Panic and Fire Exit Hardware. For FIRE EXIT HARDWARE Ratings see page 33. Conforms to UL10C and UBC 7-2.

ANSI/BHMA - Devices are BHMA certified for ANSI 156.3, Grade 1.

FINISHES - 605, 606, 612, 613, 625, 626W, 628, 630. For finish description see page 3.

CYLINDERS - Rim Type, not furnished standard. Specify when required. For cylinder details see page 19.



TOP LATCHBOLT - Stainless Steel, Deadlocking, 3/4" throw.

BOTTOM BOLT - Steel plated, independent action 5/8" throw, with adjustment range to suit 3/4 door undercut.

TOP STRIKE - No. S519 Surface applied, Investment Cast Stainless Steel, Black Powder Coated.

STILE WIDTH - See Stile Information on page 36.

LESS BOTTOM ROD (LBR) OPTION - Specify suffix "LBR" (e.g. 2703LBR). See UL FIRE LABEL RATING Chart on page 33. Fire Rated Devices include FB277 Fire Bolt Assembly. For Fire Bolt Assembly image see page 35.

DEVICE OPTIONS

Prefix	Description	Page	Suffix	Description	Page
C	Quick Connect Plugs	39	ALK	Exit Alarm: battery operated	27
DE	Delayed Egress.....	24	ALW	Exit Alarm: remote power	27
E	Electric Device.....	28	BRL	Braille Touchbar.....	35
ELR	Electric Latch Retraction.....	21	CD	Cylinder Dogging	19
FL	Fire Exit Hardware	14	DS	Door Position Monitoring Switch	29
LS	Latchbolt Monitoring Switch	29	LBR	Less Bottom Rod.....	14
MLR	Motorized Latch Retraction	40-41	LD	Less Dogging	19
Q	Wireless Access Management System..	30-32	SEC	Security Screws	3
TDS	Touchbar Monitoring Double Switch	29	SNB	Sex Nut and Bolt	3
TS	Touchbar Monitoring Switch	29	WALW	Weatherized Exit Alarm: remote power	27
WTDS	Weatherized Touchbar Mon. Dbl. Switch	29		To specify add Prefix to Device No. (e.g. TS2703)	
WTS	Weatherized Touchbar Mon. Switch	29			

To specify add Prefix to Device No. (e.g. TS2703)

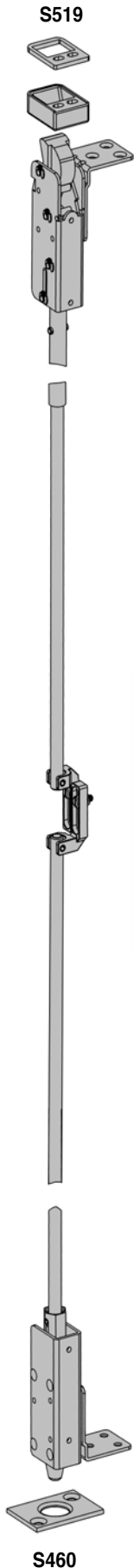

S460

1700A
"A" Grip



1700B
"B" Grip



1700C
"C" Grip



2000C
"C" Grip



1. All Trims are furnished with wrought plates and extruded or cast solid grips.
2. Specify Grip Design (A,B,C) ("A" Grip furnished standard for 1700 Series Trim, "C" Grip furnished standard for 2000 Series Trim)
3. 630 Trim is furnished for 628 Devices.
4. 626 Trim is furnished for 626W Devices.

4900A
"A" Lever



4900B
"B" Lever



4900C
"C" Lever



4900D
"D" Lever



4900K
"K" Knob



V4908A
Vandal Resistant Trim

A heavy duty lever trim designed to withstand abuse and vandalism. Composed of extra strength shock-absorbing "overload" springs and heavy duty investment cast stainless steel internal components. Lever returns to the "home" position eliminating the need to reset the lever.

1. All the escutcheons and levers are castings or forgings.
2. Specify Lever or Knob Design (A,B,C,D,K) and Handing ("A" Lever x RHRB furnished standard)
3. 626 Trim furnished for 626W, 628 and 630 Devices.
 - For Trim dimensions see page 38.
 - Trims are BHMA certified for ANSI 156.3, Grade 1.
 - Trims are through bolted and will cover 161 and 86 cutouts (except for 2000C Trim).
 - Cylinder, Rim Type, not furnished standard. For cylinder details see page 19.

ANSI Function	01 Exit Only (cover plate)	02 Dummy Trim	03 Key Retracts Latchbolt	05 Key Locks/Unlocks Thumbpiece	08 Key Locks/Unlocks Lever/Knob	14 No Cylinder Lever/Knob Always Active	15 No Cylinder Thumbpiece Always Active
Device Nos.	2701 FL2701	2702	2703** FL2703**	2705 FL2705	2708 FL2708	2714 FL2714	2715 FL2715
Trim Nos.	1701 2001 4901	1702A 2002C 4902A	1703A 2003C 4903A	1705A 2005C	4908A V4908A	4914A	1715A 2015C

Device with Trim:



Device Only: Device no., hand, finish, strike, and door size including thickness:
(e.g. TS2708CD x RHRB x 630 x 3'-0" x 7'-0" x 1-3/4")

Trim Only: Trim no., hand, finish, strike, and door size including thickness: (e.g. V4908A x RHRB x 626 x 1-3/4")

CONCEALED VERTICAL ROD EXIT DEVICES

S519

Apex 2800 Series - Reversible

Apex FL2800 Fire Exit Series - Reversible

DOORS - For all types of metal single and double door applications. Available for 1-3/4" to 2-1/4" thick, up to 4'-0" wide by 10'-0" high openings. For thicker doors, consult factory. Furnished standard for 1-3/4" thick, 3'-0" wide by 6'-8" to 8'-0" high openings.

FUNCTIONS - Functions are field selectable. The device is furnished for a desired function if specified. If not specified the "03" function is furnished standard.

BASE MATERIAL - The Cover, Touchbar, Device Channel, Lock/Hinge Side Filler and End Cap are furnished of heavy wrought Brass, Bronze or Stainless Steel. US28 Devices are furnished with Aluminum, Brass, Bronze and Stainless Steel components. See "Base Material and Finish Chart" on page 3.

CHASSIS - Lock Stile Assembly - Investment Cast Steel, Zinc Dichromated.

VERTICAL RODS - Steel, plated. Top Rod is adjustable from 6'-8" to 8'-0" or from 8'-1" to 10'-0".

TOP LATCHBOLT - Stainless Steel, Deadlocking, 3/4" throw.

TOP STRIKE - No. S519 Surface applied, Investment Cast Stainless Steel, Black Powder Coated.

BOTTOM STRIKE - No. S460 Flush mounted, Steel, Black Powder Coated.

DOGGING - 1/4" turn hex key dogging standard. NOT available on Fire Exit Hardware.

TOUCHBAR HEIGHT - 39-15/16" from floor standard. Specify required height if other than standard.

REVERSIBLE - Reversible for all functions and trims. Standard packaging RHRB.

UL LISTED - Panic and Fire Exit Hardware. For FIRE EXIT HARDWARE Ratings see page 33. Conforms to UL10C and UBC 7-2.

ANSI/BHMA - Devices are BHMA certified for ANSI 156.3, Grade 1.

FINISHES - 605, 606, 612, 613, 625, 626W, 628, 630. For Finish description see page 3.

CYLINDERS - Rim Type, not furnished standard. Specify when required. For cylinder details see page 19.



BOTTOM BOLT - Steel plated, independent action 5/8" throw, with adjustment range to suit 3/4" door undercut.

CENTER CHASSIS - Steel plated, heavy wrought Steel Assembly with lock in place Top and Bottom Latch Adjustors. Adjustment accessible through the door after installation.

STILE WIDTH - See Stile Information on page 36.

LESS BOTTOM ROD (LBR) OPTION - Specify suffix "LBR" (e.g. 2808LBR). See UL FIRE LABEL RATING chart on page 33. Fire Rated Devices include FB277 Fire Bolt Assembly. For Fire Bolt Assembly image see page 35.

DEVICE OPTIONS

Prefix	Description	Page	Suffix	Description	Page
C	Quick Connect Plugs	39	ALK	Exit Alarm: battery operated	27
DE	Delayed Egress	24	ALW	Exit Alarm: remote power	27
E	Electric Device	28	BRL	Braille Touchbar	35
ELR	Electric Latch Retraction	21	CD	Cylinder Dogging	9
FL	Fire Exit Hardware	16	DS	Door Position Monitoring Switch	29
HC	Windstorm and Hurricane Code Device	20	LBR	Less Bottom Rod	16
LS	Latchbolt Monitoring Switch	29	LD	Less Dogging	19
MLR	Motorized Latch Retraction	40-41	SEC	Security Screws	3
TDS	Touchbar Monitoring Double Switch	29	SNB	Sex Nut and Bolt	3
TS	Touchbar Monitoring Switch	29	WALW	Weatherized Exit Alarm: remote power	27
WTDS	Weatherized Touchbar Mon. Dbl. Switch	29		To specify add Prefix to Device No. (e.g. TS2803)	
WTS	Weatherized Touchbar Mon. Switch	29			

To specify add Prefix to Device No. (e.g. TS2803)

S460

1700A
"A" Grip



1700B
"B" Grip



1700C
"C" Grip



C03

Cast Plate
"Pull by others"



The CVR2803 with "Pull by Other" must be specified with No. C03 Cylinder Attachment Trim to secure the Rim Cylinder. Specify finish.

1. All Trims are furnished with wrought plates and extruded or cast solid grips.
2. Specify Grip Design (A,B,C) ("A" Grip furnished standard for C1700 Series Trim)
3. 630 Trim is furnished for 628 Devices.
4. 626 Trim is furnished for 626W Devices.

4900A
"A" Lever



4900B
"B" Lever



4900C
"C" Lever



4900D
"D" Lever



4900K
"K" Knob



V4908A
Vandal Resistant Trim

A heavy duty lever trim designed to with stand abuse and vandalism. Composed of extra strength shock-absorbing "overload" springs and heavy duty investment cast stainless steel internal components. Lever returns to the "home" position eliminating the need to reset the lever.

1. All the escutcheons and levers are castings or forgings.
2. Specify Lever or Knob Design (A,B,C,D,K) and Handing ("A" Lever x RHRB furnished standard)
3. 626 Trim furnished for 626W, 628 and 630 Devices.
 - For Trim dimensions see page 38.
 - Trims are BHMA certified for ANSI 156.3, Grade 1.
 - Trims are through bolted and will cover 161 and 86 cutouts (except for 2000C Trim).
 - Cylinder, Rim Type, not furnished standard. For cylinder details see page 19.

ANSI Function	01 Exit Only (cover plate)	02 Dummy Trim	03 Key Retracts Latchbolt	05 Key Locks/Unlocks Thumbpiece	08 Key Locks/Unlocks Lever/Knob	14 No Cylinder Lever/Knob Always Active	15 No Cylinder Thumbpiece Always Active
Device Nos.	2801 FL2801	2802	2803** FL2803**	2805 FL2805	2808 FL2808	2814 FL2814	2815 FL2815
Trim Nos.	C1701 4901	C1702A 4902A	C03 C1703A 4903A	1705A	4908A V4908A	4914A	C1715A

Device with Trim:

Device No. _____

Add **Prefix** for options, see page 16.

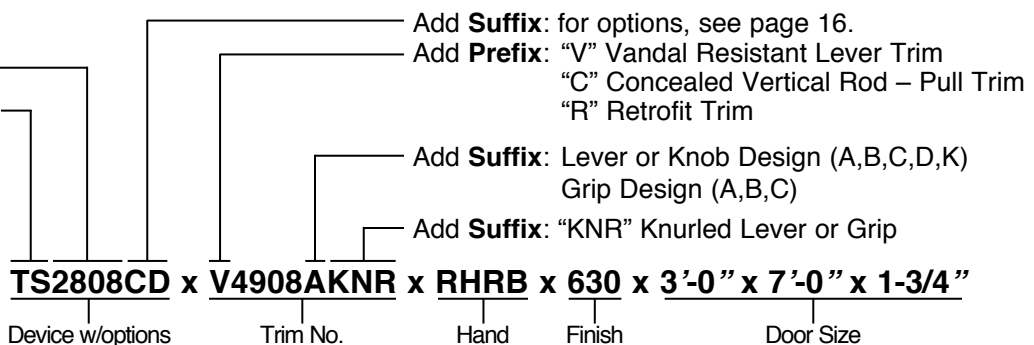

Device Only: Device no., hand, finish, strike, and door size including thickness:
(e.g. TS2808CD x RHRB x 630 x 3'-0" x 7'-0" x 1-3/4")

Trim Only: Trim no., hand, finish, strike, and door size including thickness: (e.g. V4908A x RHRB x 626 x 1-3/4")

MULLIONS



Mullion Cap
MC822



Key Removable Mullion Cap
KMC822
(Rim Cylinder required)



Mullion Cap Spacer
MCS822



Interlock
S1447



Stabilizer
ST989

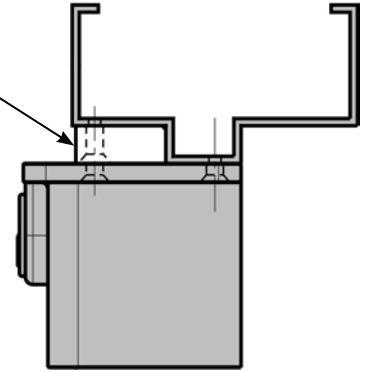

Mullion Base
MB822



Mullion Cap
MC811



Mullion Base
MB811

Removable Mullions

The Mullion is used to adapt a double door opening to two single door openings with Rim Exit Devices. When the full width of an opening is required, the mullion may be removed.

KEY REMOVABLE MULLION (KR) - Provides a secure yet quick & easy means of removing the 822 or FL822 Mullion. The mullion can be reinstalled and locked without the need of the key.

STOCK SIZE - For openings 8'-0" high. For openings less than 8'-0" high the mullion can be cut down. For openings greater than 8'-0" high using the 822, KR822 or 811 mullions, consult factory.

FINISHES - 600, 689, 695. For finish description see page 3.

822, FL822, KR822, FLKR822 Mullion

U.L. LISTED - FL822 and FLKR822 listed for Fire Exit Hardware. For FIRE LABEL RATING Chart see page 33.

MULLION - 2" x 3" Steel.

MULLION BASE - Investment Cast Steel, 2" wide 3-1/2" deep. Furnished with steel anchors for concrete floors.

INTERLOCK - Black Powder Coated Investment Cast Stainless Steel. Furnished standard for FL822 and FLKR822 Mullions. It interlocks the mullion to the Rim Active Case and S300 or S301 strike.

STABILIZERS - Black Powder Coated Steel. Stabilizers are furnished standard for FL822 and FLKR822 Mullions.

MULLION CAP SPACER - Minimum width 3-1/2". For 2-1/4" frame spacer specify part No. MCS822. For use with 822 series mullion only (e.g. 822, FL822, HC822, HCKR822, KR822, FLKR822). MCS822 Kit or 822 mullion suffix option. See "To Order" example below.

822, FL822 MULLION CAP - MC822 Investment Cast Steel, 4" wide 3-5/8" deep.

KR822, FLKR822 KEY REMOVABLE MULLION CAP ASSEMBLY - Investment Cast Steel - can be ordered to convert existing 822 or FL822 mullions to Keyed Removable Mullions. Retrofits to the hole pattern of an MC822 Mullion Cap. **To order specify:** KMC822 or KMC822F.

CYLINDER - not furnished standard - Rim Type required. See page 19 for cylinder details.

HC822, HCKR822 Mullion

MULLION - 2" x 3" Steel Mullion is reinforced with a 1-1/2" x 2-1/2" 11 gage Steel Tube. MC822 or KMC822 Mullion Cap and MB822 Mullion Base Assemblies are used to secure the HC Mullion in the door opening. The S1447 Interlock must be used to Interlock the Active Case with the strike and is furnished standard with the HC822 Mullion.

To Order: Specify Mullion No. Height Finish (e.g. MCS822 x 8'-0" x 600)

811 Mullion

MULLION - 2" x 2" Steel Mullion.

MULLION CAP - Cast 4-1/2" wide x 2-5/16", furnished with machine screws for metal frames.

MULLION BASE - Cast 2" wide x 2-3/4", furnished with sheet metal screws and plastic anchors.

To Order: Specify Mullion No. Height Finish (e.g. 822 x 8'-0" x 600)

CYLINDER FUNCTIONS

Cylinder Dogging Kit



Cylinder Dogging

Available for all Apex Series Devices except Fire Exit Hardware and Delayed Egress Devices.

Cylinder Dogging provides the ability to lock down the touch bar with a key cylinder so the door can be used in the push/pull mode. To order, specify suffix "CD" (e.g. 2103CD). Requires the use of a 1-1/4" mortise cylinder, not furnished standard. Specify when required.

Less Dogging

Available for all Apex Series Devices except Fire Exit

To convert from hex key dogging in the field, a cylinder dogging kit is available. The kit consists of a channel filler, blocking ring, cylinder locator and lock nut.



Requires the use of a 1-1/4" mortise cylinder, not furnished standard. Specify when required.

Note: The channel fillers are different lengths for narrow and wide stile devices. "NCDK" - Narrow Cylinder Dogging Kit.

To Order: specify CDK-3, NCDK-3 for up to 3-0 and CDK4, NCDK-4 for devices up to 4-0.



2110 Rim Device - Handed



2310 Mortise Device - Handed

Double Cylinder - Handed

("10" Function)

The Double Cylinder option is available on the Wide Stile Rim and Mortise Exit Devices. The inside key cylinder locks or unlocks the outside Trim and the outside key cylinder retracts the latchbolt. Specify Outside Trim with "08" function.

When only the inside key cylinder is required to lock or unlock the outside trim and no outside cylinder operation is necessary, specify outside trim with "14" function.

Cylinders - Not furnished standard.

Rim Devices - Two rim type required.

Mortise Devices - One rim type and one 1-1/4" long mortise type required.

Type	Device No.	Trim No.
Rim	2110, FL2110	x 4908A, V4908A, 4914A
Mortise	2310, FL2310	x M4908A, VM4908A, M4914A

To Order: Specify Hand and Finish

(e.g. 2110 4908A RHRB 630)

Double Cylinder Kits - Handed

The kit is available to convert 2103, FL2103, 2303 and FL2303 devices to 2110, FL2110, 2310 and FL2310 in the field.

Rim Kit No. RDC10 - Includes locking assembly, cylinder assembly, cylinder collar and active case cover. Two rim type cylinders are required, not furnished standard.

Mortise Kit No. MDC10 - Includes M310 Mortise Lock, extension assembly, cylinder bracket, cylinder collar and active case cover. One rim type and one 1-1/4" long mortise type cylinder required, not furnished standard.

To Order: Specify Hand and Finish (e.g. RDC10 RHRB 630)

Cylinders

Cylinders are not furnished standard with the device or trim. BEST® 7 pin standard. Available in 612 finish. Specify Type and finish when ordering. (e.g. 1E74 x 630)

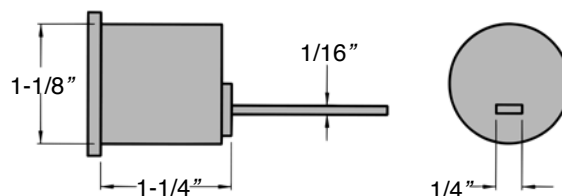

Rim Cylinder - 1E72 x Finish

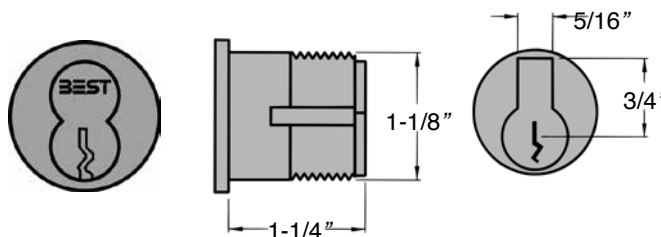

Mortise Cylinder - 1E74-C4 x Finish

WINDSTORM AND HURRICANE CODE DEVICES



HC2100 , HC2200, HC2300, HC2800 Series Devices HC822, KRHC822 Mullions

The Hurricane Devices have passed the structural tests as per South Florida Building Code Protocol. These tests are designed to provide sufficient resistance to high wind forces and wind-borne debris. The devices provide a high level of security for door openings even if hurricane rated door components are not required. A brief description of the test is provided below.

Static Air Pressure Test - Simulates wind loading by evenly distributing air pressure to the face of the door assembly in positive and negative directions. The door assembly must not have excessive deflection or deformation and must remain secure in the chamber.

Missile Impact Test - Simulates impacts created by wind driven debris by impacting the exterior face of the doors with a 2 x 4 board at 50 feet per second. The board must not pass through the doors and the doors must remain secure in the chamber.

Cyclic Wind Pressure Test - Simulates wind gusts by repeating cycles of positive and negative air pressure to determine that the integrity of the door assembly is not compromised with the Missile Impact Test. The door assembly must not have excessive deflection or deformation and must remain secure in the chamber.

Component Approval - These devices are approved as components to be used with any 16 gage Single or a Pair of Hollow Metal Doors and Frames holding a current Notice of Acceptance (NOA). The lowest Design Pressure Rating of the doors or components shall apply.

SINGLE DOOR	Door Opening	Device Series	Design Pressure
Rim Device	4'-0" W 8'-0" H	HC2100	80 PSF
Surface Vertical Rod Device	4'-0" W 8'-0" H	HC2200	80 PSF
Mortise Device	4'-0" W 8'-0" H	HC2300	60 PSF
Concealed Vertical Rod Device	4'-0" W 8'-0" H	HC2800	80 PSF

PAIR OF DOORS

Two Rim Devices with Mullion	8'-0" W 8'-0" H	HC2100 x HC822, KRHC822	80 PSF
Two Surface Vertical Rod Device	8'-0" W 8'-0" H	HC2200 x HC2200	80 PSF
Mortise Device x Concealed Vertical Rod Device	8'-0" W 8'-0" H	HC2300 x HC2800	60 PSF
Two Concealed Vertical Rod Device	8'-0" W 8'-0" H	HC2800 x HC2800	80 PSF

Compliance - HC2100, HC2200, HC2300, HC2800 Series Devices and HC822, KRHC822 Mullions comply with the Florida Building Code including the High Velocity Hurricane Zone. The Miami-Dade County Product Control Division has approved these devices to be used in Miami-Dade County and other areas where allowed by the Authority Having Jurisdiction (AHJ). Product Control **NOA No. 09-0218.09** is issued for these devices which expires on **September 30, 2014**.

To see the NOA documentation online: http://www.miamidade.gov/buildingcode/pc-search_app.asp and type in the NOA number: 05-1102.12 under the Product Search Application link.

ANSI Function	Device No.	Trim No.
01 Exit Only (cover plate)	HC2101, FLHC2101	1701
	HC2201, FLHC2201	2001
	HC2301, FLHC2301	4901
	HC2801, FLHC2801	
02 Dummy Trim	HC2102	1702A
	HC2202	2002C
	HC2302	4902A
	HC2802	
03 Key Retracts Latchbolt	HC2103, FLHC2103	C03
	HC2203, FLHC2203	1703
	HC2303, FLHC2303	2003
	HC2803, FLHC2803	4903 M4903A
05 Key Locks / Unlocks Thumbpiece	HC2105, FLHC2105	1705A
	HC2205, FLHC2205	2005A
	HC2305, FLHC2305	M1705A
	HC2805, FLHC2805	M2005A
08 Key Locks / Unlocks Lever / Knob	HC2108, FLHC2108	4908A
	HC2208, FLHC2208	V4908A
	HC2308, FLHC2308	M4908A
	HC2808, FLHC2808	VM4908A
10 Double Cylinder Inside Key Locks / Unlocks Lever / Knob		4910A
	HC2110, FLHC2110	V4910A
	HC2310, FLHC2310	M4910A
		VM4910A
14 No Cylinder Lever / Knob Always Active	HC2114, FLHC2114	
	HC2214, FLHC2214	4914A
	HC2314, FLHC2314	M4914A
	HC2814, FLHC2814	
15 No Cylinder Thumbpiece Always Active	HC2115, FLHC2115	1715A
	HC2215, FLHC2215	2015C
	HC2315, FLHC2315	M1715A
	HC2815, FLHC2815	M2015C

- Trims with the Prefix "M" are for 2300 Series Devices only.
- 2000 Series Trim not available with 2800 Series Device.
- "10" Function is handed.

Device Specifications and Options

	page
Rim Exit Devices and Trims.....	4,5
Surface Vertical Rod Devices and Trims.....	6,7
Mortise Devices and Trims	8,9
Concealed Vertical Rod Devices and Trims.....	16,17
HC822 & HCKR822 Mullions	18

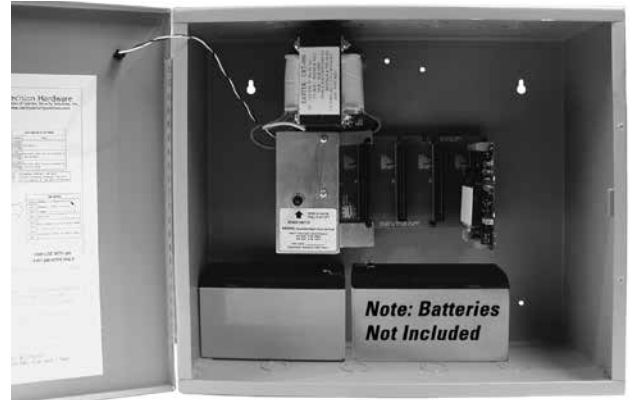
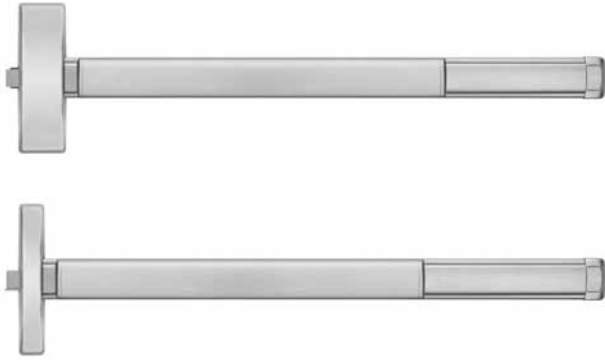

ELR150 Power supply door opened

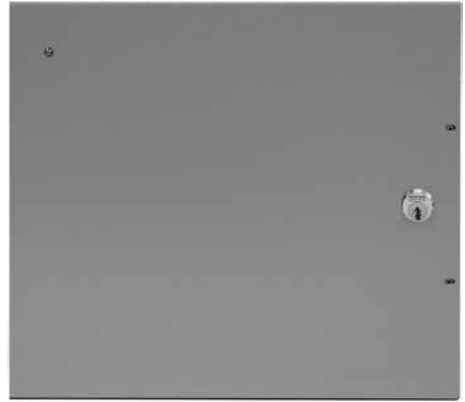

ELR150 Power supply door closed

Available for all Series Devices

The ELR option provides remote Latch Retraction of exit devices. Continuous duty solenoids retract the Latchbolt(s) for momentary unlatching or continuously for dogging. The ELR feature can be interfaced with automatic door operators, card readers, push buttons, toggle/key switches, and fire alarm systems.

- ELR option **REQUIRES** ELR150 Series Power Supply.
- UL Listed for Panic and Fire for Class II Circuitry
- ELR can be used in combination with all Apex options including Hex Key or Cylinder Dogging. ELR option is not available for (DE) Delayed Egress Devices.

Door Widths –3 Device - 2-7 to 3-0 Door
 4 Device - 3-1 to 4-0 Door

The Power Supply model number is determined based on the number of devices requiring electrical power. See To Order ELR150 Power Supply below.

To order: specify prefix “ELR” (e.g. ELR2108)

ELR Conversion Kit

A standard device can be retrofit to the Electric Latch Retraction option by ordering the kits listed below. A ELR Conversion Kit **REQUIRES** a ELR150 Series Power Supply.

To Order:

- Wide Stile Devices
- 3-0 ELRK-3, ELRKF-3
 - 4-0 ELRK-4, ELRKF-4
- Narrow Stile Devices
- 3-0 NELRK-3, NELRKF-3
 - 4-0 NELRK-4, NELRKF-4

Note: Power may be supplied through a 4-wire continuous circuit hinge (furnished by others).

Solenoid Specifications

Current Pulse (2 seconds max.) 4.75 Amp.
 Continuous 3.6 VDC / 0.8 Amp.

To Order: ELR150 Power Supply – The model number is determined based on the number of devices requiring electrical power.

- ELR150 - Power Supply, no control modules
- ELR151 - Power Supply including (1) control module to control (1) exit device
- ELR152 - Power Supply including (2) control modules to control (2) exit devices
- ELR153 - Power Supply including (3) control modules to control (3) exit devices
- ELR154 - Power Supply including (4) control modules to control (4) exit devices

To order power supply with Battery Backup specify suffix BT (e.g. ELR151BT)

ELR150 Series Power Supply

The ELR150 Series is a power supply **REQUIRED** to control ELR Devices. The power supply contains a Motherboard that will accept up to four plug-in Control Modules. Each Control Module (part #CM150-08, see page 22) controls one ELR Device and includes a Time Delay Feature. The Time Delay provides a variable (0 - 4 minutes) Latch Retraction period in response to a momentary input.

Specifications

- UL Listed for Class II Output.
- UL 294 - Conforms to U.L. 294 Standards incorporating enhanced Access Control communication capabilities.
- Circuit breakers provide protection for Motherboard
- 115 or 230 Volt user selectable switch.
- A.C. Input = 115 Volts at 1 Amp.
- Battery Back-up / Power Tap available (see page 22).
- LED Indicator - Provides clear indication that power is available to the supply.
- Keyed Cabinet - To maintain safety and security, each Power Supply is equipped with a preinstalled key-cylinder.
- Includes lockable box with key lock.
- Dimensions: 16” W x 14” H x 6” D.
- Weight: 15 lbs.

ELR POWER SUPPLY ACCESSORIES

Control Module

The CM150-08 Control Module is a card that is installed in the ELR150 Series Power Supply and controls one ELR device and includes a Time Delay Feature. The Time Delay provides a variable Latch Retraction period in response to a momentary input.

Specifications

Input

Switch Input

- Normally open

Voltage Input

- Input Voltage: 5-24VDC or VAC
- Input Current: approx. 0.005 Amp.
- Minimum pulse width: 0.25 seconds

Output

- Current Pulse: 4.75 Amp. (2 seconds max.)
- Continuous: 3.6 VDC / 0.8 Amp.

Time Delay

- User selectable: 0-4 minutes delay after input is removed

Fire Alarm Terminal

- Red LED (D3) blinks when Fire Alarm interrupts circuit
- Provides immediate termination of output

Switch Input:

- Accepts normally closed contacts or 5-24 Volts from a listed fire detecting device.

Voltage Input:

- Input Current: 0.005 Amp.
- Minimum pulse width: 0.25 seconds

Auxiliary Contacts

- Relay isolated contacts provided for remote signaling (e.g. door operator)
- Normally open or normally closed contacts are rated at 0.5 Amp., 24VDC or VAC
- Contact operation follows successful operation of the ELR device.

To Order: specify CM150-08

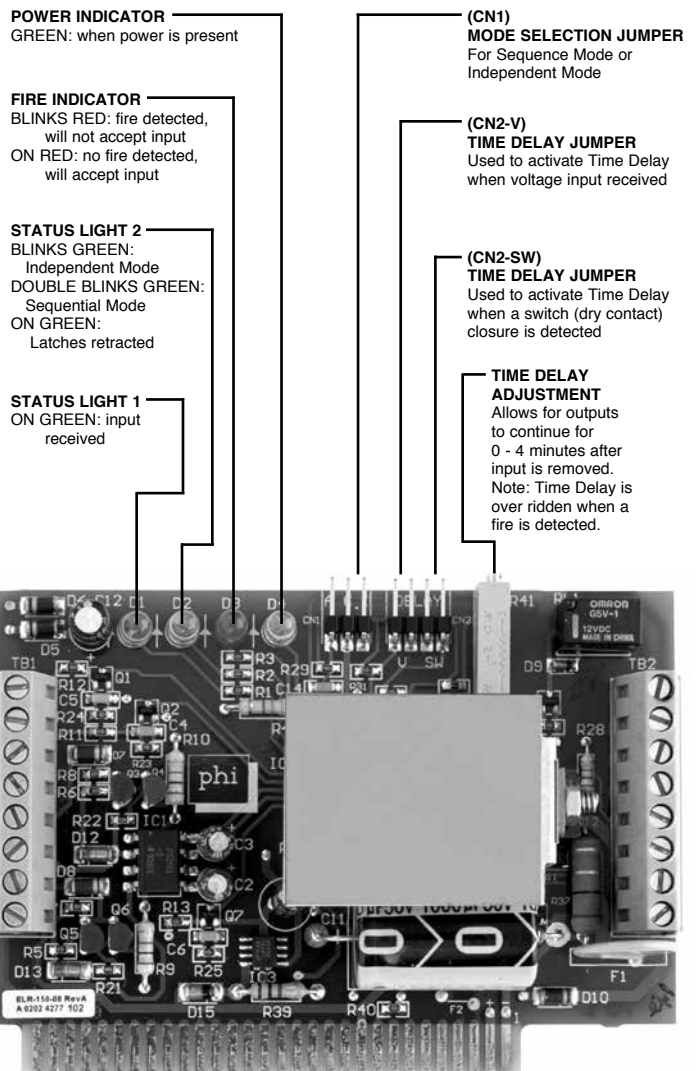

Battery Backup Power Tap

The BT150-07 Battery Backup is an optional card that can be installed in the ELR150 Series Power Supply to provide temporary power to ELR Devices in case of power shortage or outages. Uses (2) 12VDC Lead Acid batteries (furnished by others). One Amp hour set of batteries provides approximately 15 minutes of backup to four exit devices. 24V Power tap is also included to provide power to Card Readers, etc.

Electrical Ratings – 24 VDC, 0.8 Amp. - Power Tap

To Order: specify BT150-07

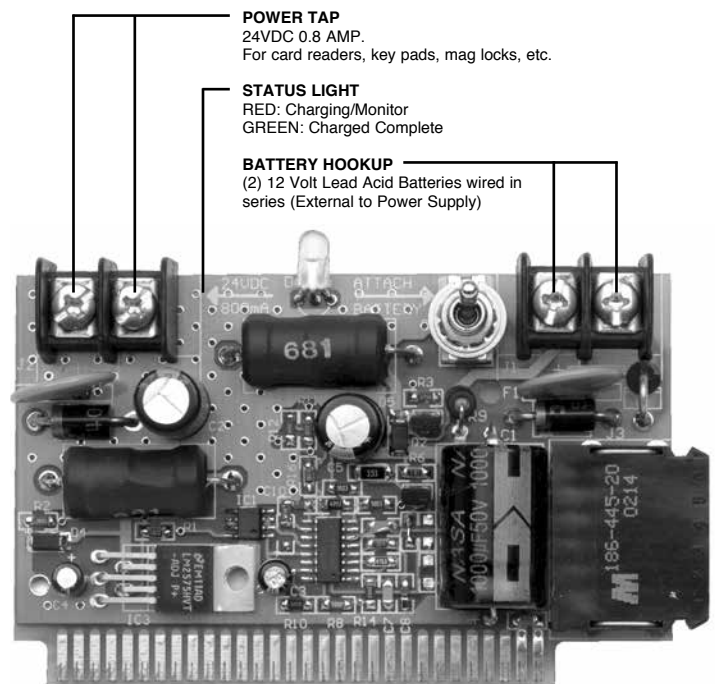

Simultaneous Pair of Doors

Pressing the push button retracts the latches on each exit device. When both exit devices have retracted latches, the control modules in the power supply signals the door operators to open the doors. The doors will remain open until released by the Time Delay feature on the Control Module.

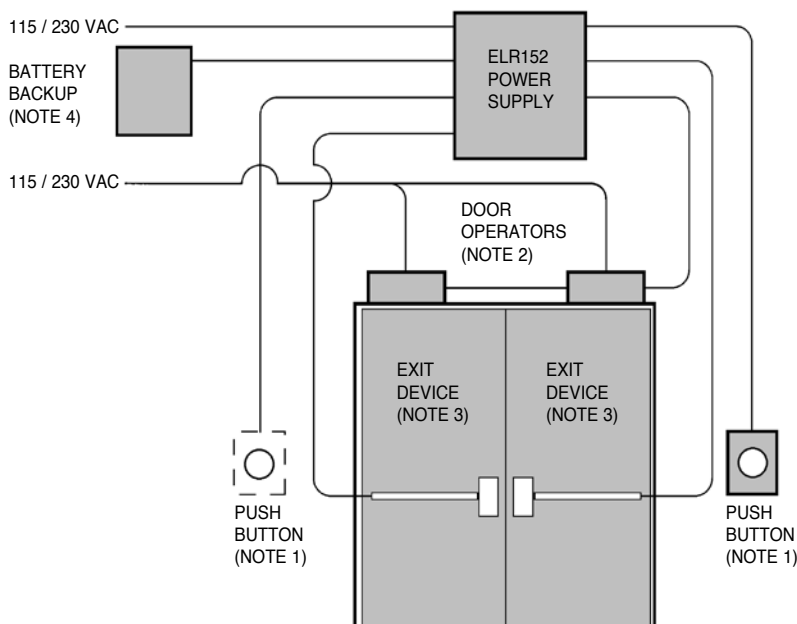

4 CONDUCTOR (28 GAGE MIN.) POWER TRANSFER REQUIRED. EPT-5 CONCEALED POWER TRANSFER (see page 29), DOOR CORD OR HINGE (FURNISHED BY OTHERS)

Two Independent Pairs of Doors

Each pair of doors are operated by pressing a push button which retracts latch(es) on each exit device. When both exit devices have retracted latches the control modules in the power supply signal the door operators (such as the Precision D-4990 Low Energy Operator) to open the doors. The doors will remain open until released by the Time Delay feature on the Control Module.

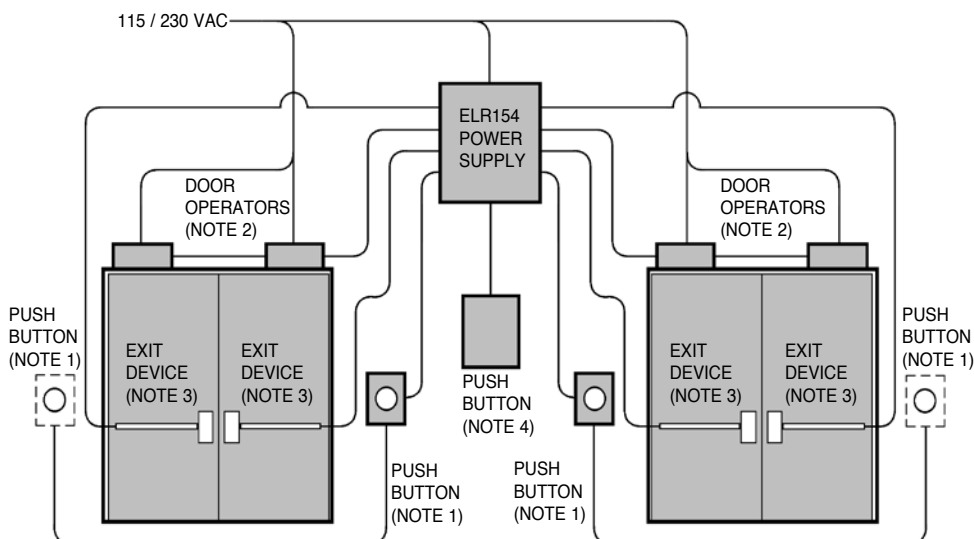

4 CONDUCTOR (28 GAGE MIN.) POWER TRANSFER REQUIRED. EPT-5 CONCEALED POWER TRANSFER (see page 29), DOOR CORD OR HINGE (FURNISHED BY OTHERS)

Notes:

1. Push Button may be replaced with Card Reader, keypad, etc., providing normally open contacts and/or voltage inputs. See hookup instructions in the ELR150 Installation Instructions.
2. Activation for Door Operators are provided by dry contact on the Control Module. (2) wires must be run from the Power Supply to each operator requiring control.
3. Each exit device requires (4) wires to operate. See chart to the right for proper gage and wire run.
4. When Battery Backup is used, (2) 12 gage wires, less than 3 feet long, connect batteries to Backup. Batteries must be mounted outside the power supply enclosure. Battery Backup has a Power Tap feature that can provide power to a Card Reader, keypad system, etc. See page 22 for details.

Wire Gage	Maximum Wire Run for 22 Gage Power Transfer	Maximum Wire Run for 28 Gage Power Transfer
16	75'-0"	55'-0"
14	125'-0"	75'-0"
12	200'-0"	---

DELAYED EGRESS



Delayed Egress

The Delayed Egress (DE) Exit Device provides a controlled egress for openings which require Panic or Fire Exit Hardware for safe egress. It is a self contained exit device, which when armed will deny exit to unauthorized personnel for 15 or 30 seconds, while simultaneously sounding a local or remote audible alarm. The Remote Monitoring feature will alert the security personnel that an attempt is being made to exit the opening. After the 15 (or 30) second delay of egress period the device will function as a standard exit device for safe egress.

OPERATION – The device secures the door in the locked mode with the Red LED indicating locked status. Depressing the Touchbar by accident or for less than the Nuisance Delay Time will sound the alarm without initiating the alarm sequence. Depressing the Touchbar with less than 15 pounds pressure, for longer than the Nuisance Delay Time will initiate an irreversible local audible beeping tone and a visual Red indicator until the device releases. After the delay egress time the lock releases and the alarm changes to a steady tone which continues to alarm until Reset. The remote monitoring contact output can be used to alert security personnel. The person depressing the Touchbar is denied egress (for 15 or 30 seconds) and security personnel are alerted for quick response.

TRIM – All standard device trims and functions are available, including “03” function, Trim Lock/Unlock will function normally even when the delayed egress feature is armed. The Device will only be affected when the Touchbar is depressed from the inside. All (DE) Rim and Mortise Devices are also available with Electric Lock/Unlock for the outside Trim. For details see page 28.

Available for all Apex Series Exit Devices.

The Delayed Egress Devices are manufactured and tested to exceed ANSI 156.3 and 156.24. Devices are UL Listed as a Controlled Exit Device (FULA) and Special Locking Arrangements (FWAX) category. Meets all requirements of NFPA 101.

Delayed Egress continued on page 25

FEATURES

FIRE ALARM CONTACTS – Fire Alarm input at any time will cut power to the delayed egress function and provide immediate egress.

ARMED-MOMENTARY EGRESS – Turning the key clockwise allows authorized personnel to exit without alarming. At the end of the field selectable time period (10, 20 or 30 seconds), the device will relock and rearm.

DE-DEVICE NETWORKING FEATURE – This feature allows a Delayed Egress device to arm, alarm, reset and disarm all devices on the same circuit. Each device will continue to operate independently for Momentary Egress.

30 SECOND DELAY – A 30 second delay option is available. A written approval from the authority having jurisdiction is required. Note: A “30 Second” decal is provided when the 30 Second Delay option is specified.

NUISANCE DELAY TIME – A Nuisance Delay Time helps avoid inadvertent activation. The alarm will sound when the touchbar is pressed, but the alarm sequence will not start unless the touchbar is held in for more than the Nuisance Delay Time. Delay Time is field selectable for 0, 1, 2 or 3 seconds.

INTEGRAL KEY SWITCH

Arm – The Key switch provides the means to locally arm the (DE) device.

Momentary Egress – The Key switch will provide temporary disarming to allow for momentary egress (10, 20 or 30 seconds) when the device is in the armed state. The Key switch will Disarm the device and it will function as a standard exit device.

Reset – During alarm sequence the device can be rearmed by the Key Switch.

Requires the use of a 1-1/4 mortise cylinder, not furnished standard. Specify when required.

LED STATUS INDICATOR (in the device) - A color coded LED indicates Arm, Disarm and Alarm status.

- Flashing Green – Arming
- Flashing Red – Armed
- Green – Unarmed
- Red – Alarmed
- Off – No Power to Device (Normal Exit)

INTERNAL ALARM – The device has a 85 db horn which will sound until the device is reset.

EXTERNAL ALARM – A set of relay contacts rated at (1 amp, 24VDC) are provided for activating external local or remote audible/visual signaling devices.

EXTERNAL INHIBIT

Arm/Rearm – Accepts a contact to Arm/Rearm the device.

Momentary Egress – Accepts a contact to provide temporary disarming to allow for momentary egress when the device is in the armed state. The Momentary Egress will be engaged as long as the switch closure is maintained.

Reset – Accepts a contact to reset the device during alarm.

DELAYED EGRESS (continued)

DELAYED EGRESS FEATURES: (Continued)

DOOR POSITION SWITCH – used in conjunction with the Delayed Egress Exit Device, the following security features are added: The Exit Device Alarm will sound if the door is not closed when the device is armed. The Alarm will sound if the door is forced open when the device is armed. While the device is in the arming stage you may exit the opening. When the door closes the arm/rearm time is cut short and the device is armed preventing unauthorized tailgating through the opening.

The PS161-6 Power Supply is designed as a power source for a variety of applications including Electric Locking, Exit Alarm and Delayed Egress Exit Devices.

The Power Supply is a 120V input with a 12 or 24V output rated at 6A. It can control up to 4 delayed egress exit devices. **Note:** Adding additional loads to the PS161-6 Power Supply (i.e., Card readers, Horns, etc.) may reduce the quantity of Delay Egress Exit Devices controlled by the power supply.

SPECIFICATIONS

Input

- Voltage: 120V AC, 60HZ
- Current: 3.5A AC
- Input fuse ratings: 5A/250V
- AC input is protected via an automatic reset circuit breaker
- Battery fuse ratings: 7.5A/32V

Output

- Voltage: 12 or 24V
- Total output: 6 amps
- Power limit/output: 2 amps/per channel
- Outputs: 8 (For Delayed Egress applications: use only 4)
- Ripple voltage: 910mV (Filtered and regulated outputs)
- Protection: Thermal and short circuit protection with auto reset overload protection.

Battery Backup Charger

- Built-in charger for sealed lead acid or gel type batteries (batteries not included)
- Maximum charge current: 1.54A
- Automatic switch over to stand-by is instantaneous with no interruption

Additional Features

- Short circuit and overload protection.
- Supervised Fire Alarm disconnect (latching or non-latching) on a normally open (NO) or normally closed (NC) trigger.

The (DE) devices are furnished with a decal which states:

**Push until alarm sounds.
Door can be opened in 15 seconds.**

Note: A “30 Second” decal is provided when the 30 Second Delay option is specified.

DE ELECTRICAL SPECIFICATIONS

Voltage: 24VDC

Current Disarmed: 100 mAmps

Current Armed: 3.2 Amps for 200 ms, 200 mAmps steady state

DOOR WIDTHS Available for 3'-0" and 4'-0" openings. For openings 3'-1" and greater, please specify door width requirements.

Note: Not available for openings less than 3'-0"

To Order: specify prefix “DE” (e.g. DEFL2108)

PS161-6 Power Supply

Required for Delayed Egress Devices



PS161-6 Power Supply

- AC fail supervision (form “C” contacts).
- Unit is complete with power supply, enclosure, battery leads, and lock.
- LED indicators for AC Input, DC output, and battery backup status.

Enclosure Dimensions

- 12.5" x 13" x 3.25" (318mm x 330.2mm x 82.55mm)

To Order: specify PS161-6 power supply

WIRE CHART AND OHMS LAW

Minimum Wire Gauge for 24 volts AC or DC

AMPS	DISTANCE IN FEET FROM POWER SOURCE TO FARTHEST LOCKING DEVICE				
	25	50	75	100	150
6.00	18	16	16	14	12

DELAYED EGRESS APPLICATION CHARTS

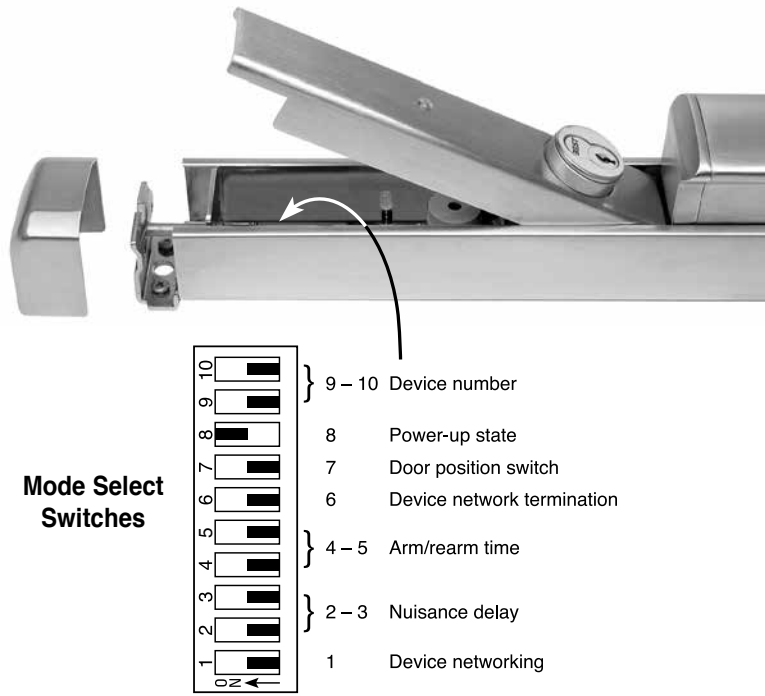

ACCESS COVER FEATURE -

The Mode Select Switch panel can be accessed through a hinge stile cover for ease of installation and maintenance without removing the device or Endcap Mounting Bracket. The access cover is secured in place by the device Endcap, which is attached with Security Screws.

MODE SELECT SWITCHES -

The following Mode Select Switch panel (see left) provides field selectable settings to suit the various Delayed Egress applications.

DELAYED EGRESS APPLICATION CHARTS

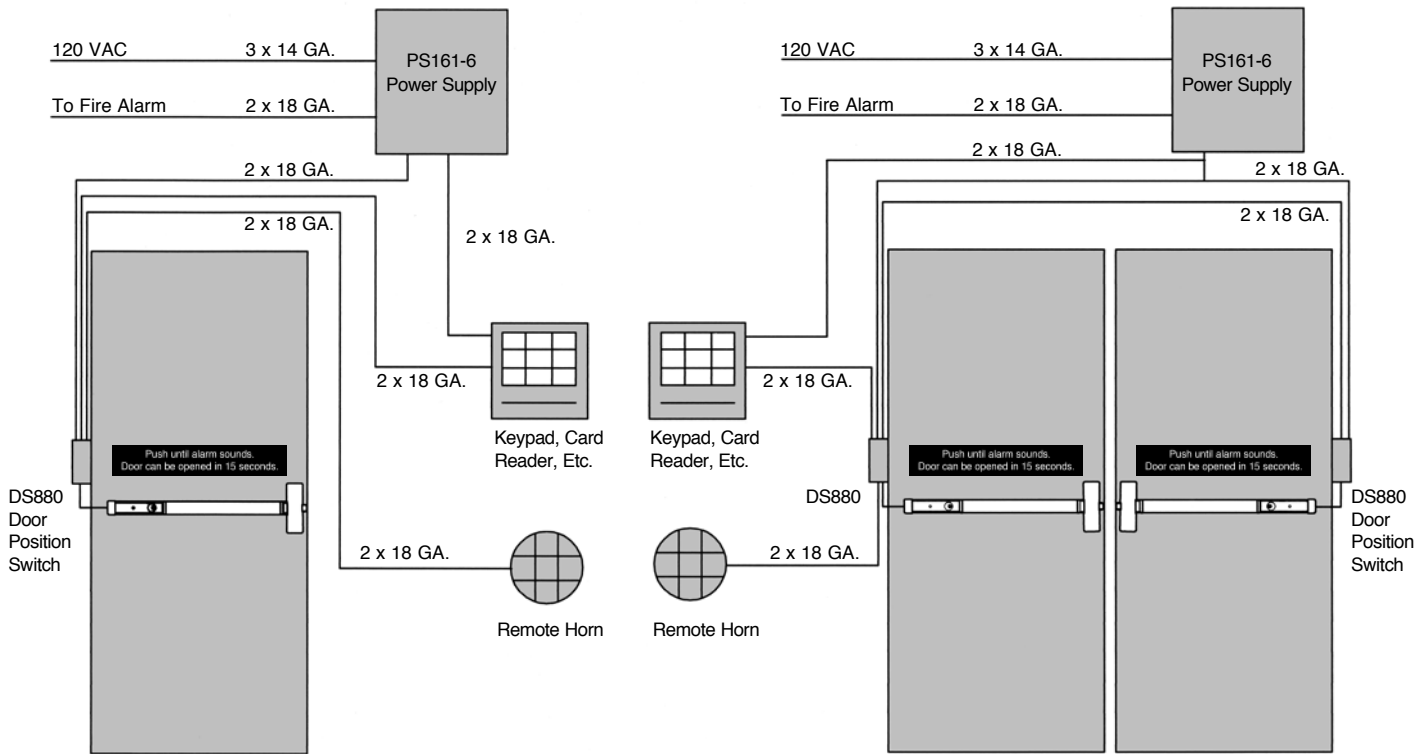

SINGLE DOOR - This application allows for remote Arm/Disarm and remote monitoring of the Delayed Egress. The Exit device will delay egress when armed and will be a normal exit device when disarmed. The DS880 (DS) Door Position Switch (page 29) prohibits the door from being held or forced open while the device is armed. The 24 VDC, remote switch, remote horn and the DS are routed through the power transfer and the fire alarm is wired to the power supply.

DOUBLE DOOR - This application allows for remote Arm/Disarm and remote monitoring of the Delayed Egress. The Exit device will delay egress when armed and will be a normal exit device when disarmed. The DS880 (DS) Door Position Switch (page 29) prohibits the door from being held or forced open while the device is armed. When one device is alarmed the other device will also go into alarm. The 24 VDC, remote switch, remote horn and the DS are routed through the power transfer and the fire alarm is wired to the power supply.

EXIT ALARM**Weatherized Exit Alarm**

Available for all Apex Series Devices. The Weatherized Exit Alarm is identical in operation to the standard Exit Alarm but incorporates a weatherized design for use on a variety of applications where contact with the elements may occur.

WALW - Remote Powered 12 to 24 VDC at 0.25 Amp., a (2) wire power transfer is required, not furnished standard. Specify WH495 Wire Harness for Remote Arm/Disarm or alternate Input Activation options.

Weather resistant loss prevention hardware designed for use in outdoor or wet environments

- Meets the requirements of MIL-STD 810F, Method 506.4, Driving Rain Test (simulating 4 in./hr. rain with 40 mph wind)
- Meets the requirements of MIL-STD 810F, Method 509.4, Salt Fog test (simulating effects of corrosive environments similar to atmospheric conditions found in coastal regions)

To Order:

Device with Weatherized Exit Alarm - add suffix "WALW" to Device No. (e.g. 2108WALW)

**Exit Alarm**

Available for all Apex Series Devices

ALK - Battery Operated, provided with a 9 Volt battery and has a audible low battery indicator. Specify WH495 Wire Harness for Remote Arm/Disarm or alternate Input Activation options.

ALW - Remote Powered 12 to 24 VDC at 0.25 Amp., a (2) wire power transfer is required, not furnished standard. Specify WH495 Wire Harness for External Wire features:

- External Arm/Disarm (On/Off)
- External Activation (to sound Alarm)

The Exit Alarm provides a simple way to audibly monitor the use of an exit device. The unit contains a Piezo Alarm which will sound when the touchbar is depressed. Alarm sounds at 80db at 10 feet.

It is also equipped with an LED indicator. The LED flashes GREEN for 20 seconds when the unit is arming and flashes RED every 20 seconds when the alarm is armed.

Note: Latch Bolt Monitoring (LS) or Door Position Switch (DS) is recommended when using Alarm option with 2200 Series Surface Vertical Rod devices.

CYLINDER

The Exit Alarm requires a standard 1-1/4 Mortise Cylinder (for cylinder details see page 19) which is used as a key switch to perform the following functions:

- To turn on (Arm) - it will allow 20 seconds to exit before alarm sounds.
- Silence and reset the alarm after unauthorized egress.
- To turn off (Disarm) the alarm for continuous unmonitored egress.
- Engage mechanical Dogging for Non-Fire Rated Devices.

WIRING HARNESS - WH495

Can be wired for one or both of the options listed below.

- Exit Alarm can be turned on (Armed) with alternate inputs. For other than our DS880 or NDS986 Door Position Switch a (2) wire power transfer hinge is required (furnished by others).
- Exit alarm can be turned on (Armed) or off (Disarmed) from a remote location. A Cylinder or Dummy Cylinder (by others) is required. Cylinders are not furnished standard. Specify when required (for cylinder details see page 19). A (2) wire power transfer is required, not furnished standard.

To Order: specify WH495

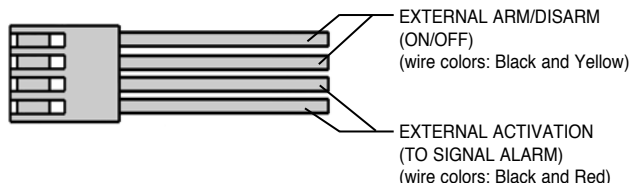

Note: The Exit Alarm is NOT required when ordering the (DE) Delayed Egress option. Note: For Battery operated kits a 9 Volt battery is included.

**Exit Alarm Kit**

Available for all Apex Devices from 3-0 to 4-0 wide doors. Furnished with Touchbar decal which states:

!! EMERGENCY EXIT ONLY !!
PUSH TO OPEN ALARM WILL SOUND

The Exit Alarm is available in Kits for Retrofit on existing devices. The channel fillers are different lengths for Narrow and Wide Stile devices. "N" denotes Narrow Stile devices.

To Order:

Device with Alarm - add suffix "ALK", "ALW" (e.g. 2108ALK)
Alarm Kits

Wide Stile Devices

2-6 & 3-0 ALK-3, ALW-3
4-0 ALK-4, ALW-4

Narrow Stile Devices

3-0 NALK-3, NALW-3
4-0 NALK-4, NALW-4

- WH495 Wiring Harness - Required for External Arming/Disarming the Alarm and External Activation to sound the Alarm.
- Kits are available in finishes 605, 606, 612, 613, 625, 628, 630. For finish description see page 3.
- To order specify Kit No. and finish (e.g. ALK-3 626).

ELECTRIC DEVICES



E2103, E2203, E2703 and E2803 Electric Device

Available for 2100, 2200, 2700 and 2800 Series Devices. The Electric Device controls entry by remote locking or unlocking of the outside trim. In addition to a 24 VDC solenoid, the exit device is also equipped with a SPDT - single pole double throw switch. The switch monitors the outside trim (locked or unlocked).

The device is furnished standard as Fail Secure (FSE). When power is off the trim is locked. Power is applied to unlock the trim. May be field converted to the Fail Safe (FS) mode. (FS) - power is applied to lock the trim. Specify (FS) or (FSE) mode when ordering. Specify outside Trim with "08" function. The outside key cylinder retracts the latchbolt for mechanical override. If outside cylinder (mechanical override) is not required, specify outside trim with "14" function.

E2103K Electric Rim Device Kit

To convert 2103, FL2103 devices to E2103, FLE2103 devices in the field. The Kit includes Trim locking assembly and Electric "E" locking assembly.

Note: The exit device can be used as a conduit for wiring to the hinge side of the door.

Electrical Ratings

Switch rated to 2 Amps at 24VDC SPDT
Solenoid current draw: 0.3 Amps.

To Order:

Device: specify prefix "E" (e.g. E2103 FSE 4908A)
Rim Device Kit: specify Kit No. (e.g. E2103K FSE)

Note: "E" locked/unlocked requires "08" or "14" function for outside lever trim.



E2303 Electric Mortise Device

The Electric Mortise Device controls entry by remote locking or unlocking of the outside trim. In addition to a 24 VDC solenoid, the mortise lock is also equipped with a SPDT - single pole double throw switch. The switch monitors the outside trim (locked or unlocked).

The device is furnished standard as Fail Secure (FSE). When power is off the trim is locked. Power is applied to unlock the trim. May be field converted to the Fail Safe (FS) mode. (FS) - power is applied to lock the trim. Specify (FS) or (FSE) mode when ordering. Specify outside Trim with "08" function. The outside key cylinder retracts the latchbolt for mechanical override. If outside cylinder (mechanical override) is not required, specify outside trim with "14" function.

Field Conversion

To convert 2303, FL2303 devices to E2303, FLE2303 devices in the field a Electric Mortise Lock is required. Specify EM303, EM303F, LSEM303 or LSEM303F (see below for Electric Mortise Locks).

Electrical Ratings

Switch rated to 2 Amps at 24VDC SPDT
Solenoid current draw: 0.2 Amps.

To Order:

Device: specify prefix "E" (e.g. E2303 FSE M4908A)

Note: "E" locked/unlocked requires "08" or "14" function for outside lever trim.

Electric Mortise Lock - Handed

The Mortise lock is available with the following electrical options:

MODEL NO.	DESCRIPTION
• LSM303, LSM303F	- latchbolt monitoring, "03" Function
• LSM308, LSM308F	- latchbolt and trim locked or unlocked monitoring, "08" Function
• EM303, EM303F	- electric lock/unlock with switch to monitor the outside trim (locked or unlocked)
• LSEM303, LSEM303F	- electric lock/unlock with switches to monitor the outside trim (locked or unlocked) and to monitor the latchbolt.

Electrical Ratings

Switch rated to 2 Amps at 24VDC SPDT
Solenoid current draw: 0.2 Amps.

Mortise Lock is furnished standard as Fail Secure (FSE). When power is off the trim is locked. Power is applied to unlock the trim. May be field converted to the Fail Safe (FS) mode.

(FS) - power is applied to lock the trim.

To Order: Specify EM303 x (FSE) or (FS) x handing x finish (e.g. EM303 FSE RHRB 630).

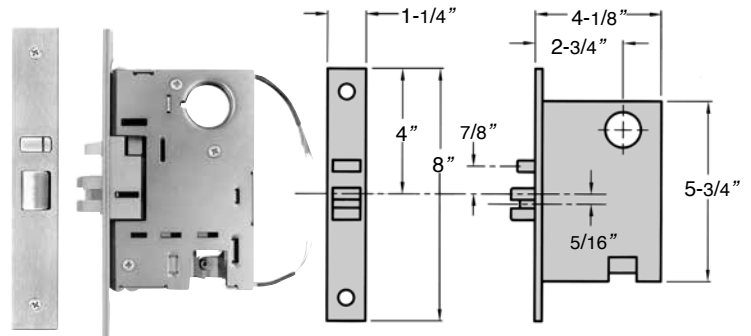

Wiring Diagram

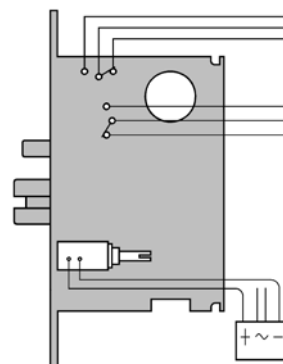

LATCHBOLT MONITORING

NORMALLY OPEN /
NORMALLY CLOSED SWITCH

LOCK / UNLOCK MONITORING

NORMALLY OPEN /
NORMALLY CLOSED SWITCH

Touchbar Monitoring

Available for all Apex Series Devices. The Touchbar Monitoring Switch is an internally mounted switch that is used to signal electromagnetic locks, horns, monitoring stations or other electronic components.

- UL Listed for Panic and Fire for Class II Circuitry.
- TS and TDS can be used in combination with all Apex options including ELR Devices.

TS (SPDT - Single Pole, Double Throw) version allows for interface with one external component. A (2) wire power transfer is required, not furnished standard.

TDS (DPDT - Double Pole, Double Throw) version allows for interface with two external components. A (4) wire power transfer is required, not furnished standard.

To Order: specify prefix TS or TDS (e.g. TS2108)

Touchbar Monitoring Conversion Kit

TS and TDS options are available as kits, specify TSK309 for Single Switch Monitoring or TDSK310 for Double Switch Monitoring.

Electrical Ratings

TS: Switch rated to 2 Amps at 24VDC SPDT

TDS: Switch rated to 2 Amps at 24VDC DPDT

Weatherized Touchbar Monitoring

Available for all Apex Series Devices. Weatherized Touchbar Switch WTS/WTDS is designed for use on a variety of exit device applications where contact with the elements may occur. Provided with the same specifications as the standard Touchbar monitoring.

- Meets the requirements of MIL-STD 810F, Method 506.4, Driving Rain Test (simulating 4 in./hr. rain with 40 mph wind)
- Meets the requirements of MIL-STD 810F, Method 509.4, Salt Fog test (simulating effects of corrosive environments similar to atmospheric conditions found in coastal regions)

To Order: specify prefix WTS or WTDS (e.g. WTS2108)

MONITORING SWITCHES

Latchbolt Monitoring

Available for Wide Stile Rim, Mortise and Vertical Rod Devices. The Latchbolt Monitoring Switch is an internally mounted switch that monitors the position of the latchbolt. Mortise LS option monitors auxiliary position. The switch can be used to signal a monitoring station or an alarm such as a Precision ALK/ALW Exit Alarm. For the security of the opening a Door Position Monitoring Switch is recommended.

- UL Listed for Panic and Fire for Class II Circuitry.
- LS and LDS can be used in combination with all Apex options including ELR Devices.

LS (SPDT - Single Pole, Double Throw) version allows for interface with one external component. A (2) wire power transfer is required, not furnished standard.

LDS (DPDT - Double Pole, Double Throw) version allows for interface with two external components. A (4) wire power transfer is required, not furnished standard.

To Order: specify prefix LS or LDS (e.g. LS2108)

Latchbolt Monitoring Conversion Kit

LS or LDS option is available as a kit for Wide Stile Devices, specify LSRK298 or LDSRK299 for Rim Devices or LSVK910 for Vertical Rod Devices. For Mortise Devices see Electric Mortise Lock, page 28.

Electrical Ratings

LS: Switch rated to 2 Amps at 24VDC SPDT

LDS: Switch rated to 2 Amps at 24VDC DPDT

Door Position Monitoring Switch



A Magnetic Reed type switch used to monitor the position of a door from a remote location. It is mounted in the Touchbar Endcap and Door Frame.

Electrical Ratings 1.5 Amps at 24VDC SPDT

To Order: Wide Stile: specify DS880 and finish.
Narrow Stile: specify NDS986 and finish.

Note: The recommended gap between the magnet and the door position switch when installed is 1/16" - 1/8". Please consider the distance between the exit device end cap and the frame. Depending on your application, the strike, and the template used, the switch and magnet can be adjusted and may extend from the device and/or frame. Please consult the factory for installation consideration.

WIRELESS ACCESS MANAGEMENT SYSTEM

Wireless Activation

The EXQ trim is part of the STANLEY® Wi-Q™ Technology Wireless Access Management System.

Wireless Access Management System includes:

- A)** – Precision Q2000 exit device
- B)** – BEST® EXQ trim
- C)** – WQX-PG portal gateway
- D)** – STANLEY® Wi-Q™ Technology Software

Note: Items ordered separately.

System Features

- Programmable time selections for desired wireless Lock/Unlock activation
- 65,000 user storage capacity
- Visual LED Indicators
- Redundant storage, up to 99,000 events
- Provides online alarm monitoring capabilities
- Battery powered by 'AA' battery pack
- Access decisions made at the door
- Remote reader diagnostics right from the PC

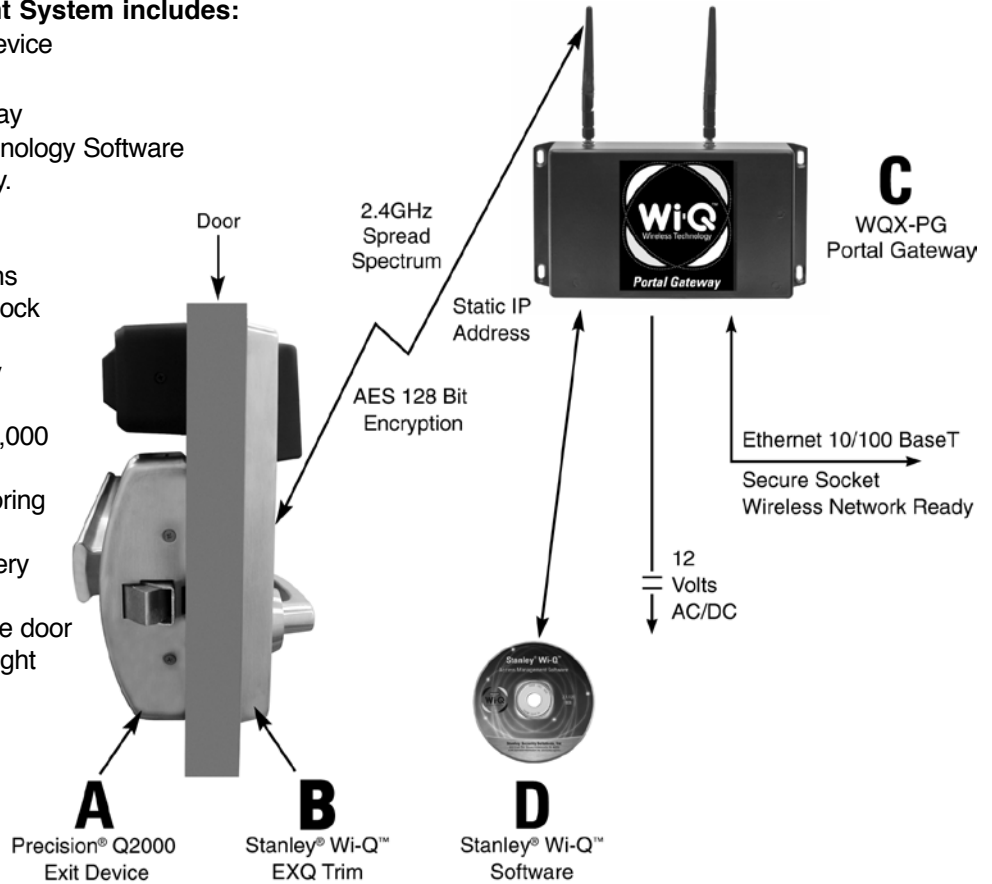

STANLEY® Wi-Q™ Wireless Technology Architecture

A) Precision Q2000 Exit Device

The Precision Q2000 exit device is equipped with the Touchbar Monitor Switch and Latchbolt Monitor Switch features. The integrated Q2000 exit device monitoring switches provide immediate feedback through connectivity with the EXQ trim software to facility security. The Q-option is available for use with Apex wide style, Rim and Vertical Rod exit devices.

Note: Wires routed through active case for EXQ Trim connection.

Note: Q option not available for 2300 series.

Q-Option Retrofit Kits

For existing Apex 2000 Series wide style rim and vertical rod exit devices without the Q-option, retrofit kits are available.

Q-Retrofit Kit includes:

Switch Assemblies, Mounting Hardware and Installation Instructions.

Electrical Ratings – Q-switches rated to 2 Amps at 24VDC SPDT.

To Order:

Q-Option – Specify prefix Q (ex.Q2103)

Q-Retrofit kit

QSRK5267 – 2103 Rim

QSVK5268 – 2203, 2703 Vertical Rod



A) Precision™ Q2103 Exit Device

Wireless Access Management System continued on pages 31 and 32.

WIRELESS ACCESS MANAGEMENT SYSTEM (continued)

B) BEST® EXQ Trim

The BEST® EXQ Trim provides battery powered online lock/unlock capability for applications utilizing exit device hardware. Used in conjunction with the STANLEY® WQX-PG Portal Gateway and Software, the EXQ trim can receive a wireless command for Lock/Unlock activation. In doing so, the respective facility has immediate efficient pull-side access control for openings that utilize exit device hardware. The EXQ comes standard with a (DS) Door Position Switch. In addition, the trim is equipped with lead wires to integrate the Q2000 Touchbar and Latchbolt Monitoring switches.

The BEST EXQ trim is offered with four different activation styles to choose from. These four types are listed below.

1. **MS** – Magnetic Stripe
2. **DV** – Dual Validation (Magnetic Stripe + Keypad)
3. **PH** – HID Proximity
4. **PM** – Indala Proximity

EXQ Trim Features

- Handing (Field reversible)

EXQ Trim Specifications

Materials – Internal parts are brass, zinc, or corrosion treated steel.

Escutcheons – 11.7”H x 3.4”W x 1.2”D.

Door thickness – Standard lock configuration designed for doors 1 3/4” (44mm) – 2 1/4” (57mm) thick.

Lever handle – Brass, bronze, or stainless steel base material. Lever styles 14 and 15 return to a minimum of 1/2” (12mm) of door surface.

Finishes – **606** – satin brass, clear coated,

613* – oxidized satin bronze, oil rubbed,

626 – satin chromium plated (brass base material),

690** – dark bronze coated (brass base material)

* 613 finish is designed to wear over time, providing an “antique” appearance.

** 690 finish will continue as a dark brown appearance over time.



**A) Precision™
Q2103 Exit Device**

**B) BEST®
EXQ Trim**

EXQ Trim Exit Device Compatibility

Apex 2000 Series Wide Style Exit Devices:

- Rim device – **2103**
- Surface vertical rod – **2203**
- Concealed vertical rod – **2703**
- Mortise – **2303**

Note: includes key-override

EXQ Trim Reader Styles



EXQ – Function

With key override	<p>Latchbolt operated by:</p> <ul style="list-style-type: none"> • Outside key • Outside lever-unless locked by internal motor drive mechanism • Touchbar <p>Outside lever locked by:</p> <ul style="list-style-type: none"> • Internal motor drive mechanism operated by time-activated electronic signal <p>Outside lever unlocked by:</p> <ul style="list-style-type: none"> • Internal motor drive mechanism operated by time-activated electronic signal or by valid card/PIN <p>Inside hardware is always unlocked</p>
------------------------------	---

For more information on other trims or trim readers refer to: BEST® EZ series, NT500, B.A.S.I.S. G, B.A.S.I.S. V, and Wireless Access Management catalogs.

Wireless Access Management System continued on pages 30 and 32

WIRELESS ACCESS MANAGEMENT SYSTEM (continued)

C) WQX-PG portal gateway

The portal gateway provides a remote integrated solution to STANLEY's® Wi-Q™ Wireless Access Management System. In doing so, all of the crucial components are linked in a secure wireless format providing efficient communication. The following is a list of the Portal Gateway features. For information on how to order, please refer to STANLEY Wireless Access Management catalog.



C) WQX-PG Portal Gateway

Wireless Portal Gateway Features

- Communicates at 2.4GHz spread spectrum to wireless readers or wireless access controllers
- Uses 802.15.4 protocol with clear channels above 802.11 to allow Wi-Fi inter-operability
- 10/100 Base-T bit Ethernet
- Provides redundant communication (locks attache to the strongest signal)
- Non-dedicated portal can communicate with 1 to 128 readers (Does not imply that 128 readers/locks will be within distance of RF range to connect. Total number of portal gateways required is based on individual system survey and requirements.)
- Ceiling mounted omnidirectional antenna included standard when WQX-PG-C is ordered
- Does not require typical controller hardwiring. Simply plug the Portal Gateway into an existing TCP/IP network and provide local power

D) STANLEY® Wi-Q™ Technology Software

The wireless access management software incorporates the functional intelligence for the entire application solution. The net result is a coordinated system with software intelligence found at the control station and remotely as well. Facility personnel can benefit from utilizing the advantages of an integrated software solution found in all aspects of the security and monitoring hardware. For more information or how to order, please refer to STANLEY's Wireless Access Management catalog.

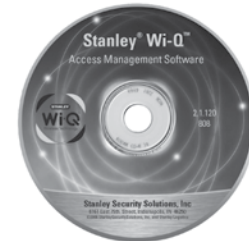

D) STANLEY® Wi-Q™ Technology Software

Wireless Access Management System continued on pages 30 & 31

ELECTRICAL POWER TRANSFER

EPT-5

EPT-5 Power Transfer with stainless steel housing and flexible tube. Secure and inconspicuous channel to bring power from the frame to the door. Narrow, shallow channel easily mortises into frame edges. Accepts up to 5/16" diameter wire bundle. Accommodates doors that swing open 120 degrees. Unit is concealed when the door is closed. Suitable for wood, aluminum or steel application

- Bright Chrome.
- Holds up to (10) 22 gauge Teflon coated wires.



To Order: specify EPT-5.

EPT-12C

The EPT-12C provides a pre-installed twelve wire harness for transfer of electric power in a discrete and effective manner. The harness is equipped with 10 wires @ 24 gauge and 2 @ 18 gauge.

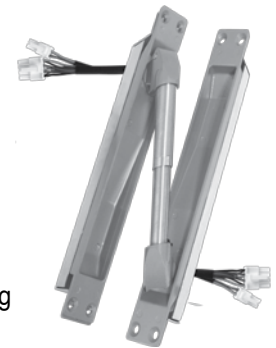

- Non-Handed
- Accommodates 180 degree swing
- UL Listed, UL10C
- Stainless Steel Housing & Spring Conduit
- 12 Wire Termination
- Pre-Installed Quick Connect Plugs

To Order: specify EPT-12C.



EPT-2 Armored flex conduit. Accepts up to 1/4 diameter wire bundle. Eighteen inches long.

To Order: specify EPT-2.

FIRE LABEL RATING

Type and Application	Door Opening	Exit Device Series	UL Fire Door Rating					20 min. Door
			(A) 3 Hour	(B) 1-1/2 Hour	(C) 3/4 Hour	(D) 1-1/2 Hour	(E) 3/4 Hour	
SINGLE DOOR								
Rim Device	4'-0"W x 10'-0"H	FL2100, FL21	•	•	•	•	•	•
Narrow Rim Devices	4'-0"W x 10'-0"H	FL2400	•	•	•	•	•	•
Mortise Device	4'-0"W x 10'-0"H	FL2300	•	•	•	•	•	•
PAIR OF DOORS								
Two Rim Devices with Mullion	8'-0"W x 8'-0"H	FL2100, FL21 x FL822, FLKR822	•	•	•	•	•	•
Two Narrow Rim Devices with Mullion	8'-0"W x 8'-0"H	FL2400 x FL822, FLKR822	•	•	•	•	•	•
Two Surface Vertical Rod Devices Swinging in the Same or Opposite Direction	8'-0"W x 10'-0"H	FL2200, FL2200LBR, FL22, FL22LBR	•	•	•	•	•	•
Mortise Lock Device x Surface Vertical Rod Device	8'-0"W x 10'-0"H	FL2300 x FL2200, FL2200LBR, FL22, FL22LBR	•	•	•	•	•	•
Mortise Lock Device x Concealed Vertical Rod Device	8'-0"W x 10'-0"H	FL2300 x FL2800, FL2800LBR	•	•	•	•	•	•
Two Narrow Concealed Vertical Rod Devices Swinging in the Same or Opposite Direction	8'-0"W x 10'-0"H	FL2600, FL2600LBR	•	•	•	•	•	•
Two Concealed Vertical Rod Devices Swinging in the Same or Opposite Direction	8'-0"W x 10'-0"H	FL2800, FL2800LBR	•	•	•	•	•	•
Wood Doors Swinging in the Same Direction								
Mortise Lock Device Wood Door Concealed Vertical Rod Device	8'-0"W x 8'-0"H	FL2300 x FL2700	•	•	•	•	•	•
Mortise Lock Device Wood Door Concealed Vertical Less Bottom Rod Device	8'-0"W x 8'-0"H	FL2300 x FL2700LBR	•	•	•	•	•	•
Wood Doors Swinging in the Same or Opposite Direction								
Two Wood Door Concealed Vertical Rod Devices	8'-0"W x 8'-0"H	FL2700	•	•	•	•	•	•
Two Wood Door Concealed Vertical Less Bottom Rod Devices	8'-0"W x 8'-0"H	FL2700LBR	•	•	•	•	•	•

All Fire Exit Hardware conforms to UL10C and UBC 7-2.
 Consult with Door Manufacturer for specific limitations on Fire Door Assemblies.

STRIKES

Rim Exit Devices

For Minimum Stile Widths see pages 36 and 37.

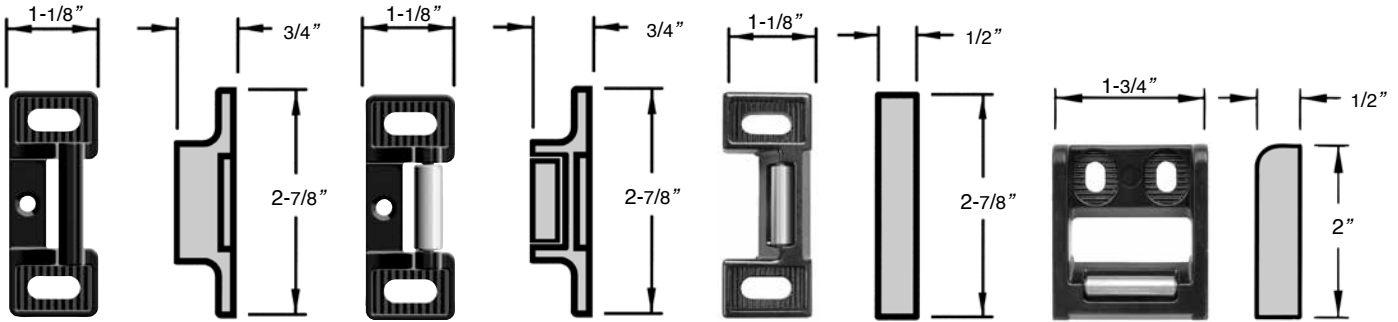

S300 Standard

For Rim and Top Strike for SVR Devices. Specify for FL2400 Devices on Pair of Doors with Mullion. Black Powder Coated Investment Cast Stainless Steel.

S301 Optional

For Rim and Top Strike for SVR Devices. Black Powder Coated Investment Cast, Stainless Steel Base and Roller.

S458 Optional

For Rim Devices. Black Powder Coated Investment Cast, Stainless Steel Base and Roller.

S988 Standard

For Narrow Stile Rim Devices. Black Powder Coated Investment Cast, Stainless Steel Base and Roller. Includes Rub Strip.

Vertical Rod Exit Devices

Top Strike - For Surface Vertical Rod Devices, S301 standard and S301 optional, see above.

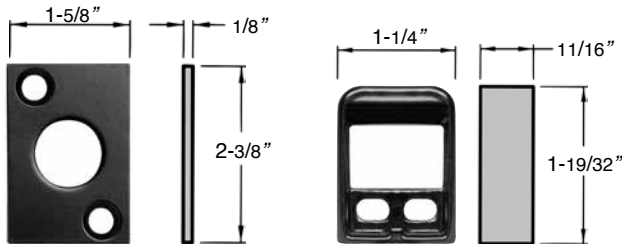

S460 Bottom Strike

For Vertical Rod Devices, Surface or Concealed. Black Powder Coated Steel.

S519 Top Strike

For Concealed Vertical Rod Devices. Black Powder Coated Investment Cast Stainless Steel.

2100 Rim x Vertical Rod Exit Device

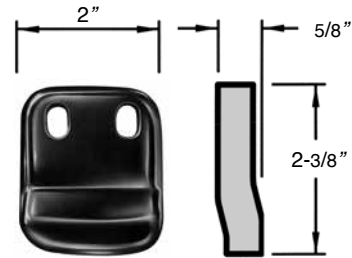

S459 Optional Rim Strike

For Non Fire Rated 2100 Rim x Vertical Rod Device on a Pair of Doors without a Mullion. Black Powder Coated Investment Cast Stainless Steel.

Mortise Exit Devices

Open Back Strikes allow a pair of doors to open and close independently. Strikes are handed. Specify Hand same as Mortise Lock (e.g. RHRB).

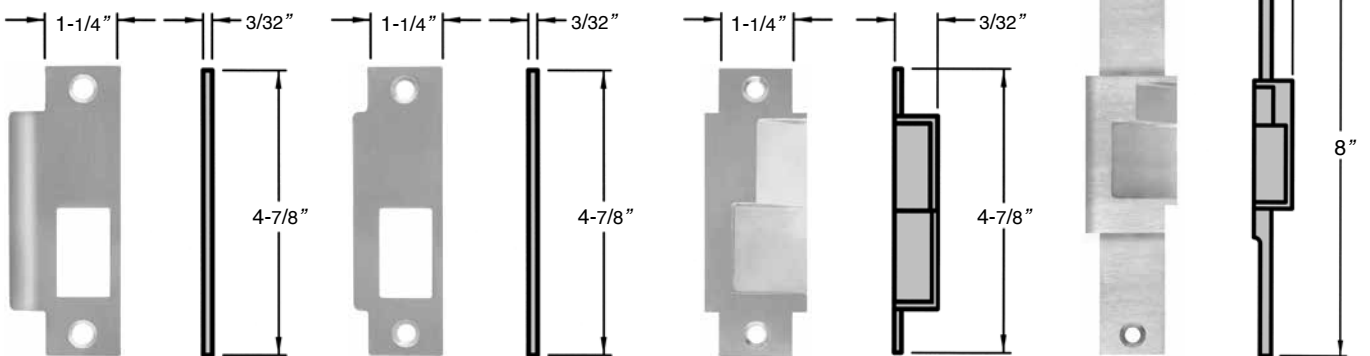

S982 Standard

Curved lip.

S983 Optional

7/8" Flat Lip to center.

For overlapping astragal.

S984 Optional

Open Back Strike For 4-7/8" x 1-1/4" door edge cutout.

S985 Optional

Open Back Strike For 8" x 1-1/4" door edge cutout.

MISCELLANEOUS COMPONENTS

Dummy Touchbar



Rigid Dummy Touchbar - Touchbar is rigid. For push/pull operation specify Dummy Trim (02 function), see page 5 for Wide Stile and page 11 for Narrow Stile Trims.

	3-0 Door	4-0 Door
Wide Stile:	671DR-3	671DR-4
Narrow Stile:	N673DR-3	N673DR-4

Active Dummy Touchbar with Microswitch - Has an internally mounted switch that is used to signal electromagnetic locks, horns, monitoring stations or other electronic components. For push/pull operation specify Dummy Trim (02 function), see page 5 for Wide Stile and page 11 for Narrow Stile Trims. Available with CD, ALK, ALW, TDS, DS and NDS options.

	3-0 Door	4-0 Door
Wide Stile:	TS672DA-3	TS672DA-4
Narrow Stile:	TSN674DA-3	TSN674DA-4

To Order: specify Device No. x finish (e.g. 672DA-3 x 630)

Shim Kit - for Narrow Stile Devices



NSMK995 used to accommodate doors with raised glass moldings. The kit consists of one 1/8" thick shim for the Chassis and one 1/8" thick shim for the End Cap Bracket Assembly.

To Order: Specify NSMK995 (e.g. 2400 NSMK995)

Wide Stile Devices are designed with a 1/4" gap (see page 2) between the back of the touchbar and the door and do not require shims. If more than 1/4" space is needed behind the device specify Shim Kit SMK994.

Braille Touchbar



Embossed Touchbar with the message "CAUTION STAIRWELL" in raised letters and Braille provides assistance to persons with impaired vision. Letters are 5/8" high and Braille is Grade 2, ADA compliant.

To Order: specify suffix "BRL" (e.g. 2103BRL)

Miscellaneous



Dogging Key
DK220 - 7/32 standard hex.



Rod Guide
RG124 - For Surface Vertical Rod Devices. Specify finish.



End Cap
EC992 - Wide Stile
NEC993 - Narrow Stile
For Hinge Stile end of all devices. Specify finish.



Mounting Bracket
MB305 - Wide Stile
NMB591 - Narrow Stile
To mount the device to the door on the Hinge Stile side.



Top Rod - 2200 and FL2200 Series.
Three stock lengths available for 7'-0", 8'-0", and 10'-0" high doors.

- TR1854** - For 7'-0" doors, rod is 36" long.
 - TR1855** - For 8'-0" doors, rod is 48" long.
 - TR1857** - For 10'-0" doors, rod is 72" long.
 - TR5197** - For 12'-0" doors, rod is 96" long.
- Note:** 12'-0" top rod is Not available in "FL" fire rated option.

For doors of lesser height rods must be field cut. Specify finish (see page 3 for Finish Descriptions).



Bottom Rod - 2200 and FL2200 Series.
Extended Bottom Rods - For exit device mounting heights greater than 39 15/16" extended bottom rods are available.
To Order: B5247-09 x finish.

BR1859 - For Touchbar location at 39-15/16" from finished floor, rod is 32-5/16" long. Specify finish (see page 3 for finish Descriptions).

FB277 - Fire bolt assembly. (See below)



Strike Plug

FB277-
Fire Bolt Assembly

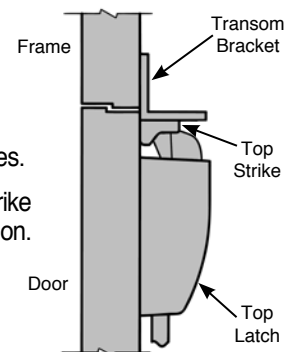

Transom Bracket - 2200 Series.

TMB453 - To mount the top strike in the flush transom application. Prepped for S300 Strike.

MINIMUM STILE WIDTH

Single Doors

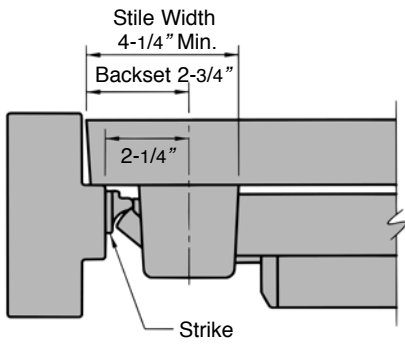

Rim Device with S300 or S301 Strikes

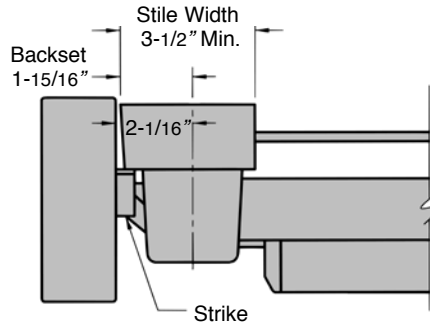

Rim Device with S988 Strikes
For 3-1/2" medium stile Aluminum doors and frames. Consult factory.

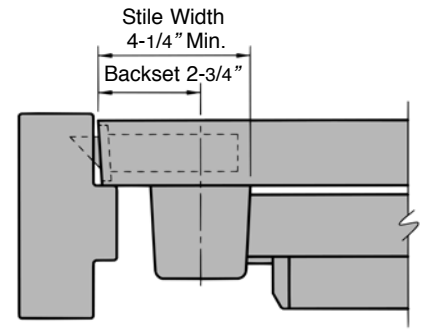

Mortise Device

Pair of Doors

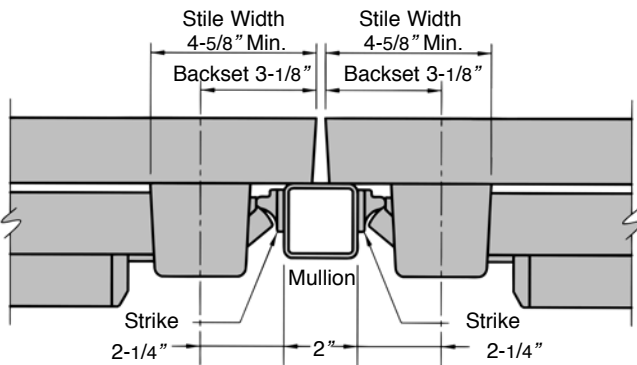

Rim Devices with S300 or S301 Strikes and Mullion

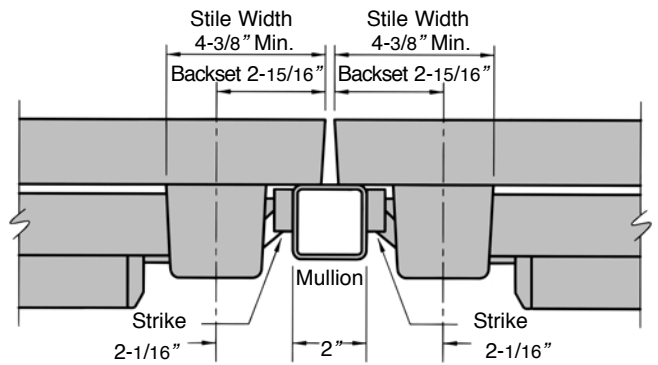

Rim Devices with S458 Strikes and Mullion

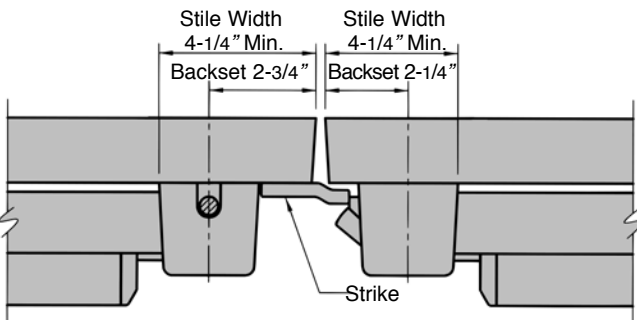

Rim Device and Vertical Rod Device with S459 Strike

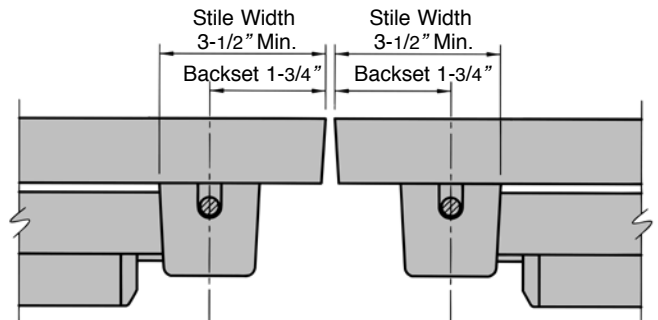

Two Vertical Rod Devices Surface or Concealed
For 3-1/2" medium stile doors consult factory.

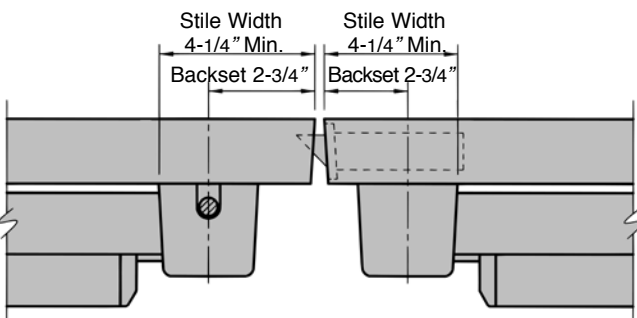

Mortise and Vertical Rod Device Surface or Concealed

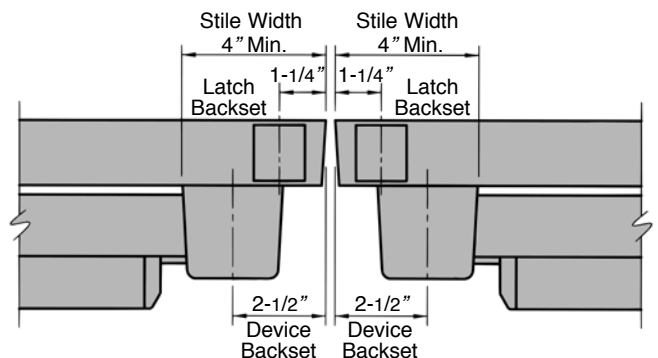

Wood Door Concealed Vertical Rod Devices

MINIMUM STILE WIDTH Single Doors – Rim Devices

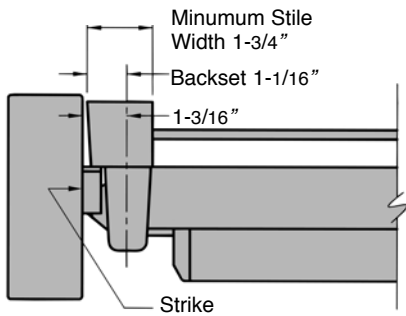

Rim Device with S988 Strike

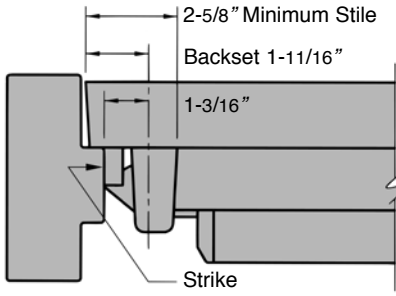

Rim Device with S458 Strike.

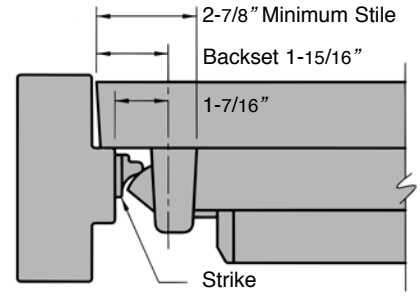

Rim Device with S300
or S301 Strikes

Pair of Doors, Rim Devices

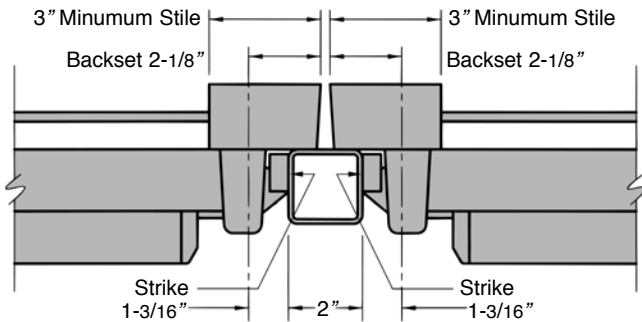

Rim Devices with S458
Strikes and Mullion

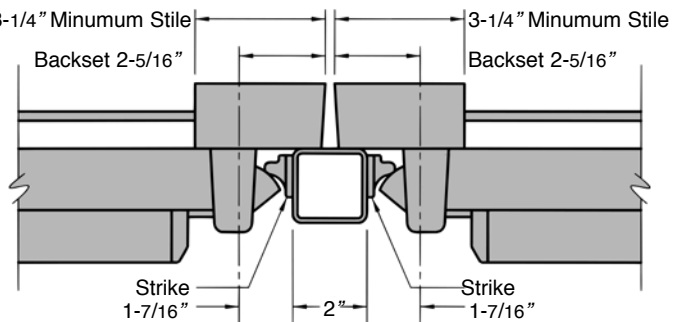

Rim Devices with S300 or S301
Strikes and Mullion

Concealed Vertical Rod Devices

Single Door

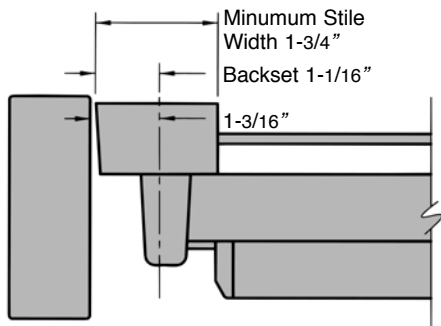

Pair of Doors

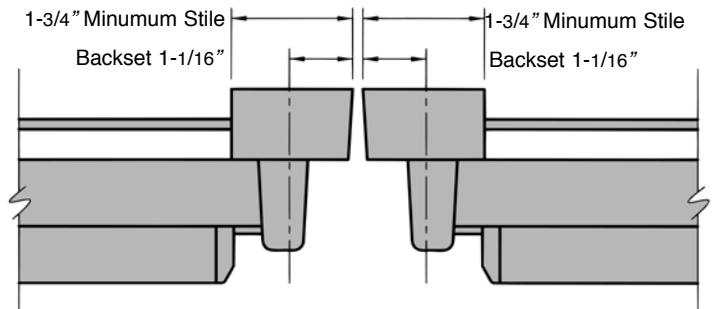

Two Concealed Vertical
Rod Devices

Device Dimensions

Wide Stile Devices

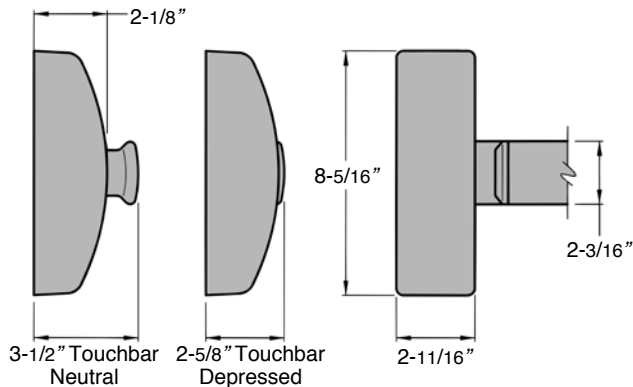

Narrow Stile Devices

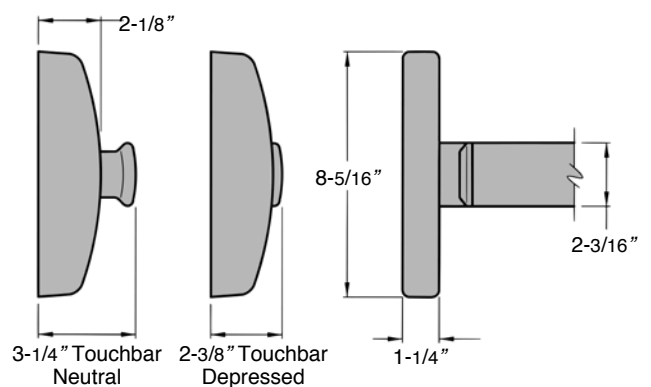

TRIM DIMENSIONS

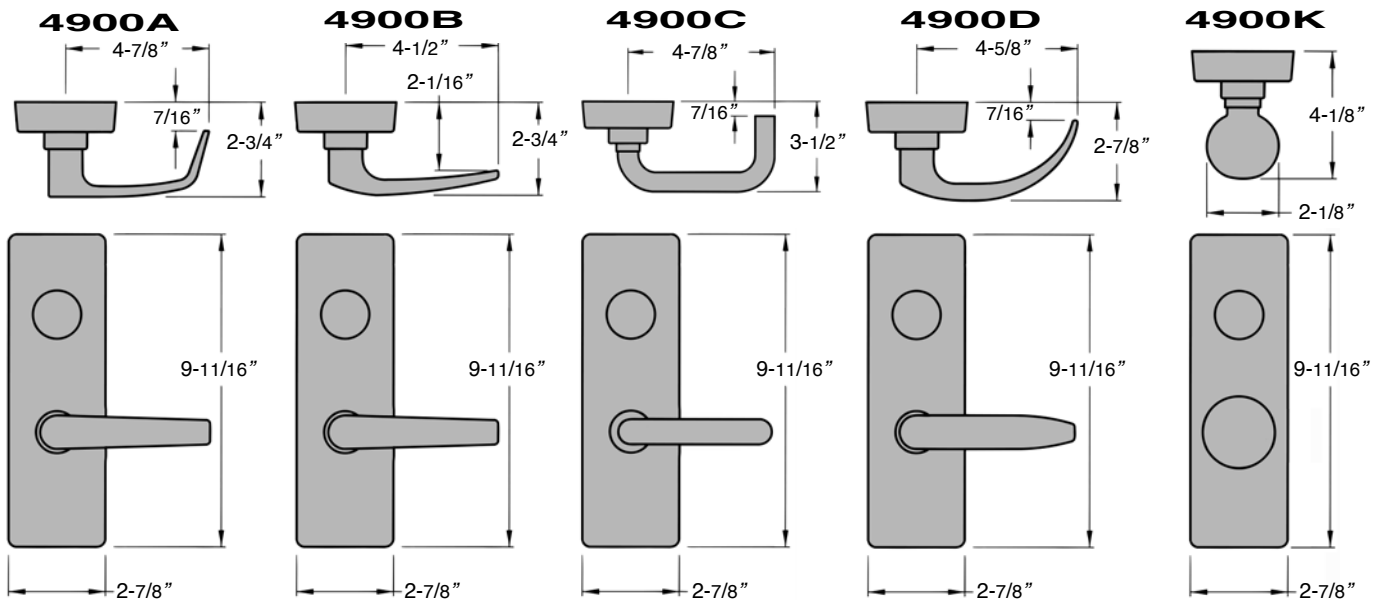
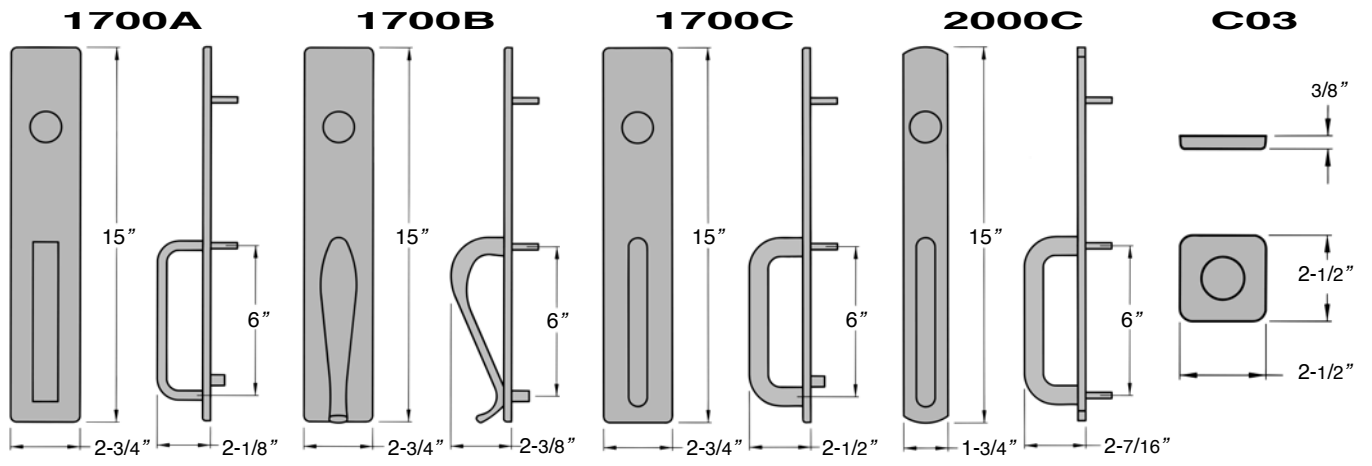

Lever Centerline 38-3/16" from Finish Floor when Device Centerline is 39-15/16".

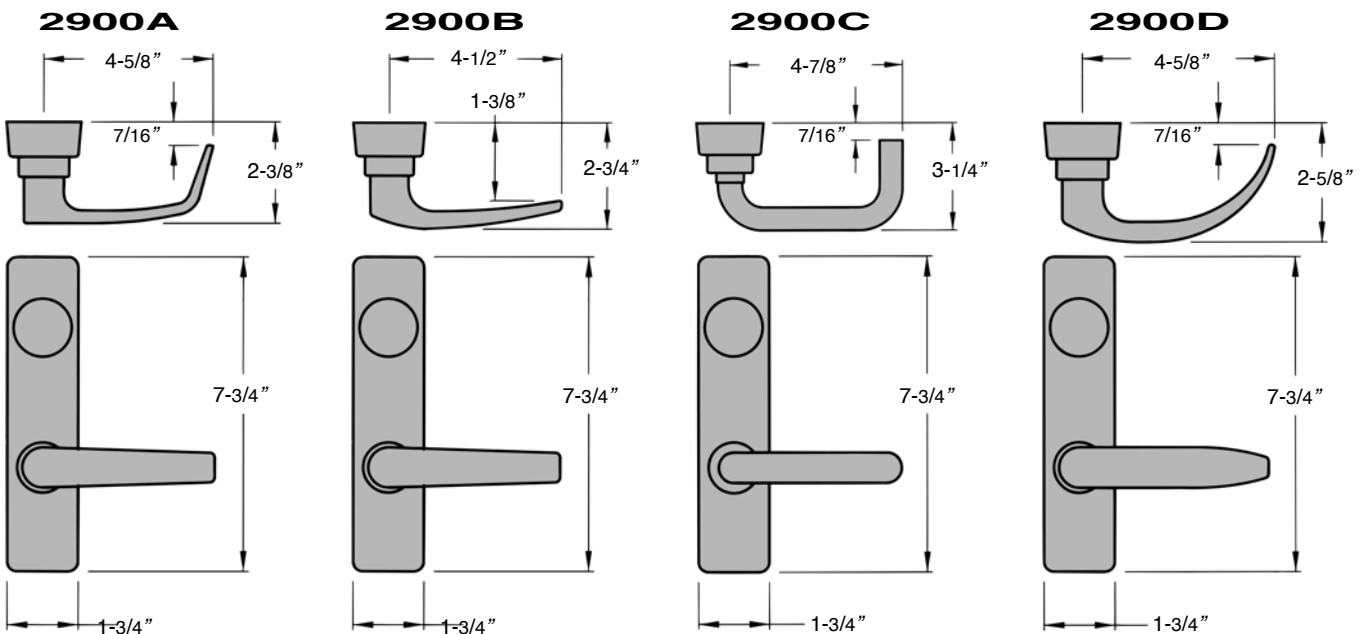

Lever Centerline 38-3/16" from Finish Floor when Device Centerline is 39-15/16".



Pre-wired Plug-in Connector:

The pre-wired plug-in connectors allow for easy installation to the respective electrical products ordered. When the plug-in connects are ordered, the Precision Hardware Electrified Exit Device ships pre-assembled with the quick connect plugs.

See illustration below for more details on how the STANLEY Quick Connect system works. For additional details please refer to the STANLEY Security website at STANLEYsecurity.com, under the Precision Hardware web page.



STANLEY Quick Connect System

STANLEY Quick Connect plug-in connectors must be used with the following components to work as a complete plug-and-play system:

1. Specify appropriate PRECISION or BEST electrified products
2. Specify correct wire harness length from door hardware to electric power transfer device or electrified hinge
3. Specify either the NEW electric power transfer (EPT-12C) or the NEW electrified hinge (CECB179-12C)
4. Specify correct wire harness length from power transfer or electrified hinge to wire extension (WH-6E)
5. Choose wire harness extension to connect to power source

How To Order

To order the STANLEY Quick Connect pre-wired plug-in connectors, include the "C" prefix for the Precision Exit Device. See example below.

PRECISION Exit Device
CELRTS 2108 XV4908A 630

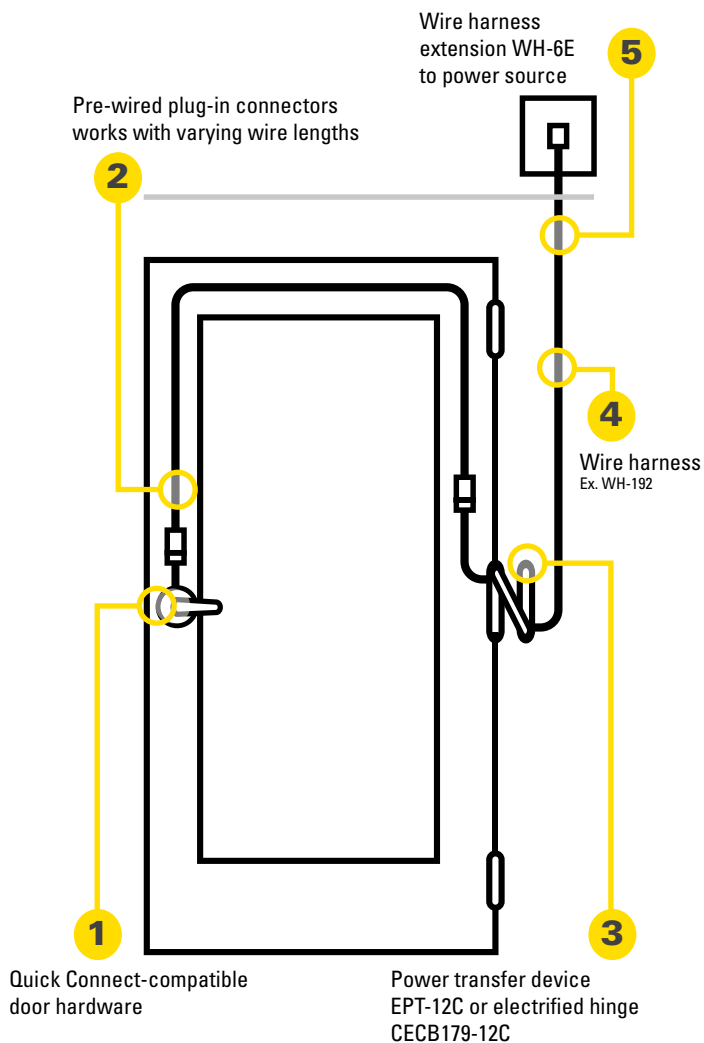

MOTORIZED LATCH RETRACTION

PRECISION Motorized Latch Retraction (MLR) exit devices feature the top-quality materials and robust engineering you expect from PRECISION, while **reducing noise, lowering current requirements, and allowing for longer wire runs** compared to power hungry solenoid-driven products. Perfect for use in applications that require more flexibility and quieter performance, PRECISION MLR engineering integrates easily with existing security frameworks.

PRECISION MLR Exit Device Specifications	
Certifications	UL-listed panic and fire UL 305 UL10C Certified ANSI/BHMA 156.3 Grade 1 FVSU/FVSU7
Power Requirements	24 Volts DC @ 1 Amp Holding current 250mA Note: Although PRECISION Power Supplies are not required, RPSMLR2 & RPSMLR2BB Power Supplies are available.
Wire Count	Two brown/white non-polarized power wires Two blue/yellow non-polarized sensor wires Note: Termination of the sensor wires is optional, but provides positive confirmation of latch retraction when used with the RPSMLR2 or RPSMLR2BB Power Supplies.
Opening Width Range	2'6" Applications: no field cutting; 2'6" openings ONLY 3'0" Applications: no field cutting; 3'0" openings ONLY 4'0" Applications: field cutting permitted down to 3'4" openings
Retrofit Kit	The MLR option can be ordered as a field retrofit kit to accommodate existing APEX 2000 Series exit devices MLR can be retrofitted to existing ELR exit devices To order the retrofit kit, specify MLR-K Note: MLR is not compatible with certain product options. For example, MLR is not compatible with mechanical dogging. Please consult the factory for additional details.
Wire Run	Maximum wire runs between the power supply and device are as follows: 200 feet with 18 gauge wire 320 feet with 16 gauge wire 500 feet with 14 gauge wire 800 feet with 12 gauge wire



MOTORIZED LATCH RETRACTION Power Supplies

The PRECISION RPSMLR2 Series is the recommended power source for PRECISION Motorized Latch Retraction (MLR) exit devices. The RPSMLR2 Series provides a code compliant source of filtered and regulated 24 Volt DC power. The RPSMLR2 Series is available in two enclosure sizes and they can each power up to (2) MLR exit devices.

PRECISION RPSMLR2 Series Power Supplies Standard Specifications	
Certifications	UL 294 ULC S-319
Input Power	120 VAC
Input	Fire alarm termination
Output Power	2 filtered & regulated 24 Volts DC outputs @ 2 Amps Holding current 200mA 1 filtered & regulated 24 Volts DC auxiliary output @ 0.8 Amps
Output	2 normal open relay outputs Outputs can be wired for 2 different modes: - 1 second delay prior to relay output - Positive confirmation of latch retraction prior to signaling the operator when used in conjunction with MLR exit device sensor wires
Battery Backup (RPSMLR2BB only)	Built in charger for sealed lead acid or gel batteries Automatically switches to stand-by if AC fails Charging current 650mA max Batteries are not included
Visual Indicators	AC power, green LED – Indicates presence of AC power Triggered input, 2 red LEDs – Indicates input activation Fire alarm interface, green LED – Indicates fire alarm activation Battery status, red LED – Indicates low battery during AC power failure
Enclosure Dimensions	RPSMLR2: 12.5"x7.5"x3.25" RPSMLR2BB: 13.5"x13"x3.25"
Security	Keyed enclosure



RPSMLR2



RPSMLR2BB





Stanley Security Solutions, a business division of Stanley Black & Decker, is a provider of integrated access control and security solutions for institutional, commercial and industrial businesses and organizations. Stanley Security Solutions delivers a comprehensive suite of security products, software and integrated systems with a strong emphasis on service. Stanley Security Solutions is committed to extending its position as a leading comprehensive resource for a broad and extensive array of solutions that span the entire security spectrum.