



# 9K SERIES

## SERVICE MANUAL



## CREDITS/COPYRIGHT

Copyright © 2000–2004 Stanley Security Solutions, Inc. and Stanley Logistics, Inc. All rights reserved. Printed in the United States of America.

Information in this document is subject to change without notice and does not represent a commitment on the part of Stanley Security Solutions, Inc. The software described in this document are furnished under a license agreement or nondisclosure agreement.

This publication is intended to be an accurate description and set of instructions pertaining to its subject matter. However, as with any publication of this complexity, errors or omissions are possible. Please call your BEST® distributor or Stanley Security Solutions, Inc., Best Access Systems at (317) 849-2250 if you see any errors or have any questions. No part of this manual and/or databases may be reproduced or transmitted in any form or by any means, electronic or mechanical, including photocopying, recording, or information storage and retrieval systems, for any purpose, without the express written permission of Stanley Security Solutions, Inc.

This document is distributed as is, without warranty of any kind, either express or implied, respecting the contents of this book, including but not limited to implied warranties for the publication's quality, performance, merchantability, or fitness for any particular purpose. Neither Stanley Security Solutions, Inc., nor its dealers or distributors shall be liable to the user or any other person or entity with respect to any liability, loss, or damage caused or alleged to be caused directly or indirectly by this publication.

Written and designed by Stanley Security Solutions, Inc. and Avalon Group, Inc., Indianapolis, Indiana.

T56082 Rev C 1798144 ER-7991-6 November 2004

---

---

# CONTENTS

## FIGURES VII

## GETTING STARTED 1-1

- Introduction 1-1
- Certifications and standards 1-2
  - 9K Series Locks 1-2
  - Electrified Locks 1-2
  - Accessories 1-2
- Documentation package 1-3
- Technical support 1-4
  - Support services 1-4
  - Telephone technical support 1-4
  - Training seminars 1-4

## FUNCTIONS AND PARTS LISTS 2-1

- Function descriptions 2-2
  - Single-keyed functions 2-3
  - Double-keyed functions 2-5
  - Non-keyed functions 2-7
  - Special functions 2-8
  - Electrified cylindrical functions 2-11
  - Functions by ANSI designation 2-11
- Standard functions 2-12
  - AB function chassis—entrance lock (ANSI F109) 2-12
  - C function chassis—corridor lock (ANSI F88) 2-13
  - D function chassis—storeroom lock (ANSI F86) 2-14
  - E function chassis—service station lock (ANSI F92) 2-15
  - G function chassis—storeroom lock (ANSI F91) 2-16

H function chassis—hotel guest room lock with indicator (ANSI F93)	2-17
HJ function chassis—hotel guest room lock without indicator	2-17
L function chassis—privacy lock (ANSI F76)	2-18
N function chassis—passage lock (ANSI F75)	2-19
NX function chassis—exit lock (ANSI F89)	2-20
P function chassis—patio lock (ANSI F77)	2-21
R function chassis—classroom lock (ANSI F84)	2-22
S function chassis—communicating lock (ANSI F80)	2-23
T function chassis—dormitory lock (ANSI F90)	2-24
W function chassis—utility or institutional lock (ANSI F87)	2-25
Y function chassis—exit lock	2-26
Non-standard functions	2-27
A function chassis—entrance lock (ANSI F81)	2-27
B function chassis—office lock (ANSI F82)	2-28
DR function chassis—special lock	2-29
DZ function chassis—closet or storeroom lock	2-30
EA function chassis—entrance or office lock	2-31
IN function chassis—intruder lock	2-32
LL function chassis—hospital privacy lock	2-33
M function chassis—communicating lock (ANSI F78)	2-34
Q function chassis—exit lock (ANSI F83)	2-35
RD function chassis—special lock	2-36
RZ function chassis—closet or storeroom lock	2-37
XD function chassis—special lock	2-38
XR function chassis—special lock	2-39
YD function chassis—exit lock	2-40
YR function chassis—special lock	2-41
Z function chassis—closet lock	2-42
Electrified functions	2-43
DEL function chassis—electrically locked fail safe	2-43
DEU function chassis—electrically unlocked fail safe	2-45
Function conversion	2-47
Trim parts	2-50
Standard strikes and strike boxes	2-50
Non-standard strikes	2-50
Lead-lined parts	2-51
Roses, rose liners, and rose spacers	2-52
Standard levers and components	2-54
Dummy trim	2-57
Latches	2-58
Installation tools	2-59

**SERVICE AND MAINTENANCE 3-1**

- Maintenance tools 3-2
- Replacing Parts 3-3
  - Replacing the lever 3-3
  - Replacing the inside rose and rose liner 3-4
  - Replacing the outside rose and liner assembly 3-6
  - Replacing the RQE rose liner for electrified locks 3-7
  - Replacing the button assembly 3-8
  - Replacing the lever keeper spring 3-10
  - Replacing the lever return spring 3-11
  - Replacing the key release cam assembly 3-15
  - Replacing the spring drive plate 3-16
  - Replacing the sleeve assembly 3-17
  - Replacing the solenoid for electrified locks 3-19
- Adding the RQE switch to electrified locks 3-19
- Reversing the solenoid when changing the function 3-20
- Lubricating the cores 3-20
- Aligning the chassis and trim 3-21
- Cam positioning instructions 3-22
  - Positioning the cam for C function locks 3-22
  - Positioning the cam for G and IN function locks 3-23
- Emergency key instructions for H and HJ function locks 3-24
- Troubleshooting 3-25

**INSTALLATION INSTRUCTIONS A-1****INDEX B-1**



---

---

# FIGURES

## FUNCTIONS AND PARTS LISTS

- Understanding function drawings 2-2
- Standard strikes and strike boxes 2-50
- Understanding strike lip measurement 2-50
- Cross-section of 9K locks showing lead-lined parts 2-51
- Standard lever components 2-55
- Lever components for use with non-interchangeable cores 2-56
- Dummy trim parts 2-57
- Latches 2-58
- Installation tools 2-59

## SERVICE AND MAINTENANCE

- Maintenance tools 3-2
- Removing the keyed lever 3-3
- Removing the plain lever or button lever 3-3
- Replacing the lever (keyed lever shown) 3-4
- Removing the inside rose with the spanner wrench 3-4
- Removing the two through-bolts 3-5
- Replacing the inside rose and rose liner 3-5
- Removing the outside rose and liner assembly 3-6
- Replacing the outside rose and liner assembly 3-7
- Removing the button assembly 3-8
- Inserting the button assembly into the sleeve 3-9
- Bending the button assembly tab 3-9
- Removing the lever keeper spring 3-10

Positioning the lever keeper spring	3-10
Lever keeper spring in position	3-11
Separating the hub and sleeve assembly from the chassis	3-12
Removing the thrust plate	3-12
Removing the lever return spring	3-12
Positioning the lever return spring	3-13
Inserting the lever return spring	3-13
Installing the thrust plate	3-14
Positioning the retractor assembly	3-14
Installing the retractor assembly	3-15
Removing the key release cam assembly	3-15
Installing the key release cam assembly	3-16
Removing the spring drive plate	3-16
Positioning the sleeve	3-17
Installing the spring drive plate	3-17
Removing the sleeve assembly from the hub	3-18
Replacing the sleeve assembly	3-18
Positioning the sleeve	3-19
Engaging the retractor in the latch	3-21
Correct position of the C function inside locking cam	3-22
Correct position of the G and IN function locking cam	3-23
Intermediate position of the G and IN function locking cam	3-23
Inserting the emergency key	3-24



# 1

---

---

## GETTING STARTED

### INTRODUCTION

The *9K Series Service Manual* contains essential information to help you maintain your 9K Series Lock. This manual addresses standard and electrified 9K Series Locks. Throughout this manual, the term electrified is used to refer to 93KW-95KW DEL, DEU function locks.

## CERTIFICATIONS AND STANDARDS

- 9K Series Locks**
- The locks comply with ANSI A156.2, Series 4000 Grade 1 standards.
  - The locks are listed by Underwriter's Laboratories for use on 3 Hr., A label single swinging doors (4' x 10'), or pairs of doors 8' wide and 10' high.
  - When used with the 3/4" throw latch, the locks comply with Miami-Dade County standards with a design pressure rating of ±90 PSF for single doors and ±50 PSF for double door openings.
  - The AB, C, D, EA, G, IN, NX, Q, R, and YD function locks comply with ANSI A250.13 Windstorm standards with a design load rating of 1750 pounds.
  - The chassis conforms to ANSI A115.2.
  - The 8KS3 strike fits the standard door frame cutout as specified in ANSI A115.2.
  - The #14 and #15 lever handles conform to California Administrative Code Title 19 and Title 24.
  - The #14, #15, and #16 lever handles conform to the Illinois Accessibility Standard.
- Electrified Locks**
- The 9KW Locks are UL listed for GYQS electrically controlled single point locks or latches.
  - The 9KW Locks are approved by the California State Fire Marshal (CSFM) pursuant to section 13144.1 of the California Health and Safety Code.
  - The 9KW Locks are approved by the city of New York Board of Standards and Appeals under calendar number 730-89-SA. See CSFM listing number 4136-1175:103.
- Accessories**
- The 8W599 transformer is UL listed.
  - The 8WCON AC to DC converter full wave bridge rectifier is UL recognized.

## DOCUMENTATION PACKAGE

The following documentation is available to help you with the installation, start-up, and maintenance of your 9K Series Lock.

The installation and assembly instructions also can be ordered separately:

<b>Document Title</b>	<b>Doc. No.</b>
<i>Installation Instructions for 9K Cylindrical Locks<sup>a</sup></i>	T56075
<i>Single and Double Dummy Trim Assembly Instructions for 9K1DT/2DT</i>	T56076
<i>Wiring Instructions for 8K and 9K Series Electrified Cylindrical Locks with RQE<sup>a</sup></i>	T56090
<i>Door Wiring Instructions for Electrically-Operated Locks</i>	T61926

a. These installation instructions are included in this manual. See Installation Instructions on [page A-1](#).

The templates required for lock installations also can be ordered separately:

<b>Document Title</b>	<b>Doc. No.</b>
<i>K08 Template for Door and Frame Preparation for 63, 73, 83, 93K Locks</i>	T56052
<i>K09 Template for Door and Frame Preparation for 63, 73, 83, 93K Locks</i>	T56053
<i>K10 Template for Door and Frame Preparation for 64, 84, 94K Locks</i>	T56054
<i>K11 Template for Door and Frame Preparation for 64, 84, 94K</i>	T56055
<i>K12 Template for Door Frame Preparation for 65, 85, 95K</i>	T56056
<i>K13 Template for Door Frame Preparation for 65, 85, 95K</i>	T56057
<i>K18 Template for 8K/9K Dummy Trim</i>	T56059
<i>K21 Template for Strike Specification for Cylindrical Locks</i>	T56060
<i>W14 Template; Installation Specifications for 83KW/93KW-85KW/95KW IDH Max Cylindrical Locks</i>	T60777
<i>W16 Template; Installation Template for 83KW/93KW-85KW/95KW IDH Max Cylindrical Locks</i>	T60773

## TECHNICAL SUPPORT

**Support services** When you have a question about the 9K Series Lock, your first resource for help is the *9K Series Service Manual*. If you cannot find a satisfactory answer, contact your local BEST Representative.

**Telephone technical support** A factory-trained Certified Product Specialist (CPS) is available in your area whenever you need help. Before you call, however, please make sure you are where the 9K Series Lock is, and that you are prepared to give the following information:

- what happened and what you were doing when the question arose
- what you have done so far to answer the question.

Best Access Systems Representatives provide telephone technical support for all 9K Series products. You may locate the representative nearest you by calling (317) 849-2250 Monday through Friday, between 7:00 a.m. and 4:00 p.m. eastern standard time; or visit the web page, [www.BestAccess.com](http://www.BestAccess.com).

**Training seminars** BEST holds training sessions for its customers. The seminars are specifically designed for BEST end-users who have a registered BEST masterkeyed system and registered BEST security equipment. If you are interested, you may contact your local BEST representative for details.

# 2

---

---

## FUNCTIONS AND PARTS LISTS

The following pages contain function descriptions for all 9K Series Locks. This chapter also includes exploded diagrams that show all field serviceable mechanical parts, diagrams of trim and other miscellaneous parts, and function conversion information.

## FUNCTION DESCRIPTIONS

This section includes function descriptions grouped by the following function types:

- single-keyed ([page 2-3](#))
- double-keyed ([page 2-5](#))
- non-keyed ([page 2-7](#))
- special ([page 2-8](#))
- electrified ([page 2-11](#)).

For a list of the BEST designation for each ANSI-defined function, see [page 2-11](#).

**Note:** If the function is ANSI defined, the ANSI designation appears by the function name.

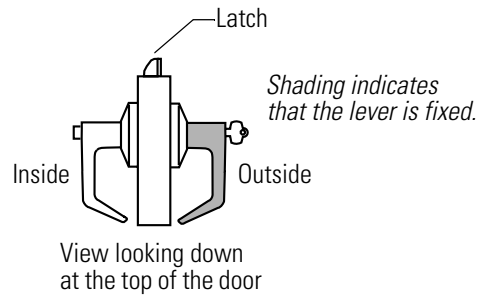

**Figure 2.1** Understanding function drawings

**Single-keyed functions** The following lists describe how the latchbolt, outside lever, and inside lever operate for each single-keyed 9K function.

**AB—Entrance (ANSI F109)**

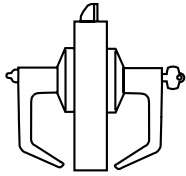

**Latchbolt operated by:**

- inside lever
- outside key
- outside lever when the inside button is in the unlocked position

**Outside lever locked by:**

- inside button when pushed in
- inside button when pushed in and rotated clockwise

**Outside lever unlocked by:**

- inside lever when the inside button is pushed in but not rotated
- outside key when the inside button is pushed in but not rotated
- closing the door when the inside button is pushed in but not rotated

**Inside lever is always unlocked**

**D—Storeroom (ANSI F86)**

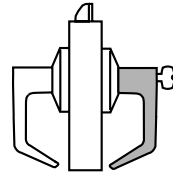

**Latchbolt operated by:**

- inside lever
- outside key

**Outside lever is always fixed  
Inside lever is always unlocked**

**E—Service station (ANSI F92)**

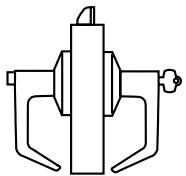

**Latchbolt operated by:**

- inside lever
- outside key
- outside lever when the inside button is in the unlocked position

**Outside lever locked by:**

- inside slotted button
- inside slotted button when pushed in and rotated clockwise

**Outside lever unlocked by:**

- inside lever
- inside slotted button when rotated counterclockwise
- outside key
- closing the door when the inside button is pushed in but not rotated

**Inside lever is always unlocked**

**H and HJ—Hotel guest room (ANSI F93 for H only)**

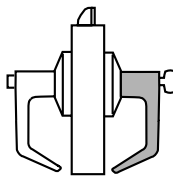

**Latchbolt operated by:**

- inside lever
- outside key when the inside button is in the unlocked position
- special emergency key after the core is removed with the control key

**Outside lever is always fixed  
Key block feature released by:**

- inside lever
- closing the door

**Inside lever is always unlocked**

**Note:** For the H function, pushing the inside button projects an “Occupied” indicator in the outside lever and blocks all operating keys. For the HJ function, pushing the inside button blocks all operating keys.

### R-Classroom (ANSI F84)

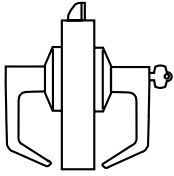

**Latchbolt operated by:**

- inside lever
- outside key
- outside lever when not locked

**Outside lever locked by:**

- outside key

**Outside lever unlocked by:**

- outside key

**Inside lever is always  
unlocked**

### T-Dormitory (ANSI F90)

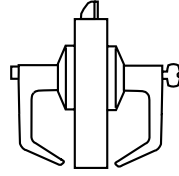

**Latchbolt operated by:**

- inside lever
- outside lever when not locked

**Outside lever locked by:**

- inside button
- outside key

**Outside lever unlocked by:**

- inside lever when the inside  
button is pushed in
- outside key
- closing the door when the  
inside button is pushed in

**Inside lever is always  
unlocked**



**Double-keyed functions**

The following lists describe how the latchbolt, outside lever, and inside lever operate for each double-keyed 9K function.

**Warning:**

**Locks that secure both sides of the door are controlled by building codes and the Life Safety Code®. In an emergency exit situation, failure to quickly unlock the door could be hazardous, or even fatal.**

**C–Corridor (ANSI F88)**

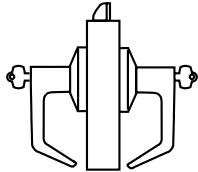

**Latchbolt operated by:**

- inside lever
- outside key
- outside lever when not locked

**Outside lever locked by:**

- inside key

**Outside lever unlocked by:**

- inside key

**Inside lever is always unlocked**

**G–Storeroom (ANSI F91)**

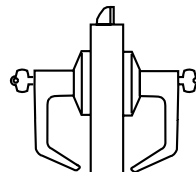

**Latchbolt operated by:**

- inside lever when not locked
- outside lever when not locked

**Outside lever locked by:**

- inside key
- outside key

**Outside lever unlocked by:**

- inside key
- outside key

**Inside lever locked by:**

- inside key
- outside key

**Inside lever unlocked by:**

- inside key
- outside key

**Note:** Turning the key in either the inside or outside lever locks or unlocks both sides.

**IN–Intruder**

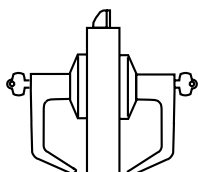

**Latchbolt operated by:**

- inside lever
- outside lever when not locked

**Outside lever locked by:**

- inside key
- outside key

**Outside lever unlocked by:**

- inside key
- outside key

**Inside lever is always unlocked**

**S–Communicating (ANSI F80)**

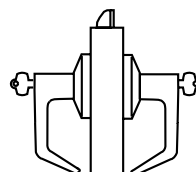

**Latchbolt operated by:**

- inside key
- inside lever when not locked
- outside key
- outside lever when not locked

**Outside lever locked by:**

- outside key

**Outside lever unlocked by:**

- outside key

**Inside lever locked by:**

- inside key

**Inside lever unlocked by:**

- inside key

**Note:** Turning the key in either lever locks or unlocks that lever independently.

### W-Institutional (ANSI F87)

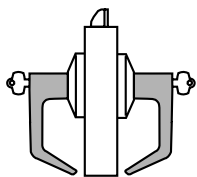

**Latchbolt operated by:**

- inside key
- outside key

**Outside lever is always fixed**

**Inside lever is always fixed**

---

**Non-keyed functions** The following lists describe how the latchbolt, outside lever, and inside lever operate for each non-keyed 9K function.

**L-Privacy (ANSI F76)**

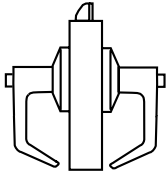

- Latchbolt operated by:**
- inside lever
  - outside lever when the inside button is in the unlocked position
- Outside lever locked by:**
- inside button
- Outside lever unlocked by:**
- inside lever
  - outside slotted button when pushed in and rotated counterclockwise
  - closing the door
- Inside lever is always unlocked**

**N-Passage (ANSI F75)**

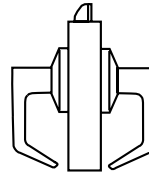

- Latchbolt operated by:**
- inside lever
  - outside lever
- Outside lever is always unlocked**
- Inside lever is always unlocked**

**NX-Exit (ANSI F89)**

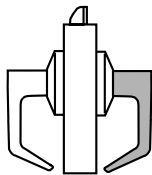

- Latchbolt operated by:**
- inside lever
- Outside lever is always fixed**
- Inside lever is always unlocked**

**P-Patio (ANSI F77)**

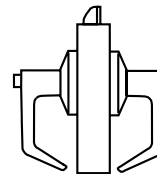

- Latchbolt operated by:**
- inside lever
  - outside lever when the inside button is in the unlocked position
- Outside lever locked by:**
- inside button
- Outside lever unlocked by:**
- inside lever
  - closing the door
- Inside lever is always unlocked**

**Y-Exit**

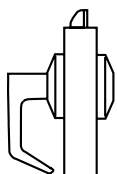

- Latchbolt operated by:**
- inside lever
- Inside lever is always unlocked**

**1DT-Single dummy trim**



This lock is a single, surface mounted lever for an inactive door or a non-latching door.

**2DT-Double dummy trim**

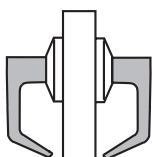

This lock is a through-bolt mounted pair of matching levers for an inactive door or a non-latching door.

**Special functions**

The following lists describe how the latchbolt, outside lever, and inside lever operate for each special 9K function.

**Warning:**

**Locks that secure both sides of the door are controlled by building codes and the Life Safety Code®. In an emergency exit situation, failure to quickly unlock the door could be hazardous, or even fatal.**

**A—Dormitory or storeroom lock (ANSI F81)**

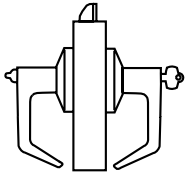

**Latchbolt operated by:**

- inside lever
- outside key
- outside lever when the inside button is in the unlocked position

**Outside lever locked by:**

- inside button

**Outside lever unlocked by:**

- inside button

**Inside lever is always unlocked**

**Note:** Inside button must be rotated counterclockwise to unlock the outside lever.

**B—Office (ANSI F82)**

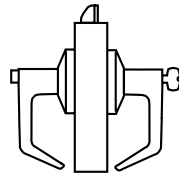

**Latchbolt operated by:**

- inside lever
- outside key
- outside lever when the inside button is in the unlocked position

**Outside lever locked by:**

- inside button

**Outside lever unlocked by:**

- inside lever

- outside key

**Inside lever is always unlocked**

**Note:** Inside button is released by turning the key in the outside lever or rotating the inside lever. Closing the door does not release the inside button.

**DZ—Closet or storeroom**

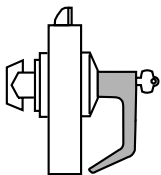

**Latchbolt operated by:**

- inside turn knob
- outside key

**Outside lever is always fixed**

**Inside turn knob is always unlocked**

**EA—Entrance or Office**

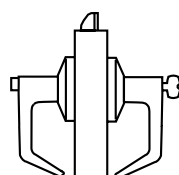

**Latchbolt operated by:**

- inside lever
- outside key
- outside lever when the inside button is in the unlocked position

**Outside lever locked by:**

- inside button

- inside button when pushed in and rotated clockwise

**Outside lever unlocked by:**

- inside lever

- inside button when rotated counterclockwise

- outside key

**Inside lever is always unlocked**

**Note:** Turning the slotted button keeps the outside lever locked until the button is turned back.

**RZ—Closet or storeroom**

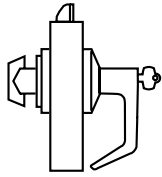

- Latchbolt operated by:**
- inside turn knob
  - outside key
  - outside lever when not locked
- Outside lever locked by:**
- outside key
- Outside lever unlocked by:**
- outside key
- Inside turn knob is always unlocked**

**XD—Special**

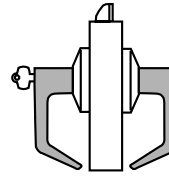

- Latchbolt operated by:**
- inside key
- Outside lever is always fixed**
- Inside lever is always fixed**

**XR—Special**

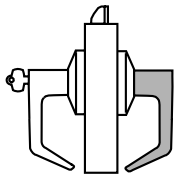

- Latchbolt operated by:**
- inside key
  - inside lever when not locked
- Outside lever is always fixed**
- Inside lever locked by:**
- inside key
- Inside lever unlocked by:**
- inside key

**YD—Exit**

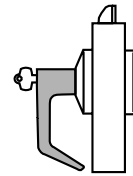

- Latchbolt operated by:**
- inside key
- Inside lever is always fixed**

**YR—Special**

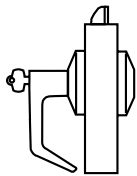

- Latchbolt operated by:**
- inside key
  - inside lever when not locked
- Inside lever locked by:**
- inside key
- Inside lever unlocked by:**
- inside key

**DR—Special**

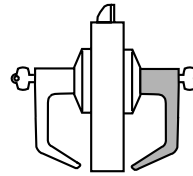

- Latchbolt operated by:**
- inside key
  - inside lever when not locked
  - outside key
- Outside lever is always fixed**
- Inside lever locked by:**
- inside key
- Inside lever unlocked by:**
- inside key

**RD—Special**

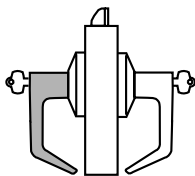

- Latchbolt operated by:**
- inside key
  - outside key
  - outside lever when not locked
- Outside lever locked by:**
- outside key
- Outside lever unlocked by:**
- outside key
- Inside lever is always fixed**

**LL—Hospital privacy**

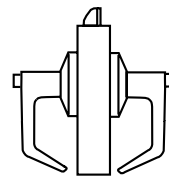

- Latchbolt operated by:**
- inside lever
  - outside lever when not locked
- Outside lever locked by:**
- inside button when pushed in
- Outside lever unlocked by:**
- inside lever
  - outside button when pushed in and rotated counterclockwise
  - closing the door
- Inside lever is always unlocked**

### M-Communicating (ANSI F78)

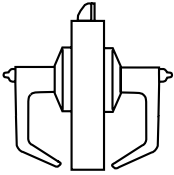

- Latchbolt operated by:**
- inside lever when not locked
  - outside lever when not locked
- Outside lever locked by:**
- inside button
- Outside lever unlocked by:**
- inside button
- Inside lever locked by:**
- outside button
- Inside lever unlocked by:**
- outside button

**Note:** Do not use this function for rooms that have no other entrance.

### Z-Closet latch

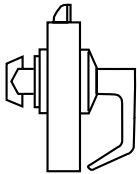

- Latchbolt operated by:**
- inside turn knob
  - outside lever
- Outside lever is always unlocked**
- Inside turn knob is always unlocked**

### Q-Exit (ANSI F83)

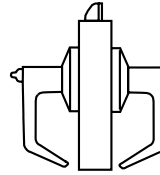

- Latchbolt operated by:**
- inside lever
  - outside lever when not locked
- Outside lever locked by:**
- inside button
- Outside lever unlocked by:**
- inside button
- Inside lever is always unlocked**

**Electrified cylindrical functions**

The following lists describe how the latchbolt, outside lever, and inside lever operate for each electrified 9K function.

**DEL—Electrically Locked—Fail Safe**

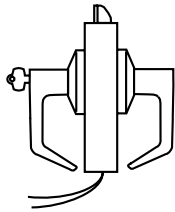

**Latchbolt operated by:**

- inside lever
- outside lever when electric power is removed from the solenoid
- outside key

**Outside lever locked by:**

- applying 24 VDC to the solenoid; remains locked only while power continues to be applied

**Outside lever unlocked by:**

- removing 24 VDC from the solenoid

**Inside lever is always unlocked**

**DEU—Electrically Unlocked—Fail Secure**

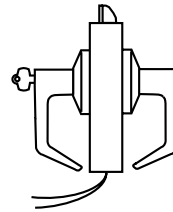

**Latchbolt operated by:**

- inside lever
- outside lever when electric power is applied to the solenoid
- outside key

**Outside lever locked by:**

- removing 24 VDC from the solenoid

**Outside lever unlocked by:**

- applying 24 VDC to the solenoid; remains unlocked only while power continues to be applied

**Inside lever is always unlocked**

Functions by ANSI designation	ANSI no.	Function
	F75	N
	F76	L
	F77	P
	F78	M
	F80	S
	F81	A
	F82	B
	F83	Q
	F84	R
	F86	D
	F87	W
	F88	C
	F89	NX
	F90	T
	F91	G
	F92	E
	F93	H
	F109	AB

# STANDARD FUNCTIONS AB FUNCTION CHASSIS—ENTRANCE LOCK (ANSI F109)

Item	Part No.	Qty.	Description
1	B55692	1	Turn button assembly <sup>a</sup>
2	A55685	1	Inside hub and locking pin assembly
3	B55610	1	Non-keyed sleeve and driver assembly
4	B55518	2	Lever return spring
5	B55504	2	Thrust plate
6	B54172	1	Chassis cover
7	B54886	1	Retractor assembly with long catchplate
8	A55673	1	Key release cam assembly
9	C55515	1	Spring drive plate
10	A55687	1	Keyed sleeve assembly <i>or</i>
not shown	A55725	1	Keyed sleeve assembly <sup>b</sup>
11	D55571	1	Outside hub <i>or</i>
not shown	D56003	1	Outside hub, lost motion
12	A55505	2	Chassis screw

a. Specify finish.

b. For use with non-interchangeable cores.

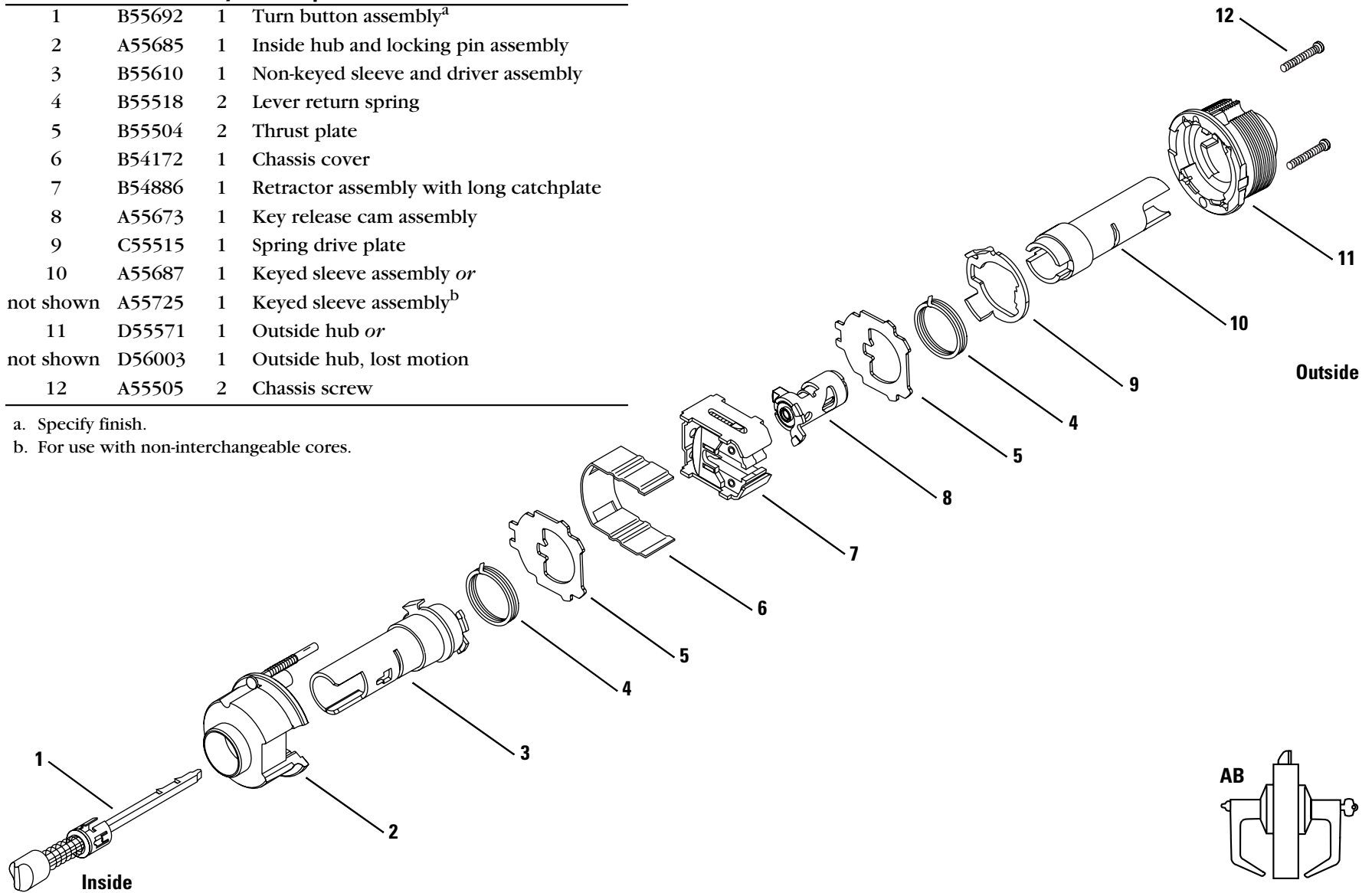

**Figure 2.2** AB function exploded diagram



## C FUNCTION CHASSIS—CORRIDOR LOCK (ANSI F88)

Item	Part No.	Qty.	Description
1	A55685	1	Inside hub and locking pin assembly <i>or</i>
not shown	A56008	1	Inside hub assembly, lost motion
2	B55700	1	Sleeve & key release cam assembly <i>or</i>
not shown	B56024	1	Sleeve & key release cam assembly <sup>a</sup>
3	C55515	2	Spring drive plate
4	B55518	2	Lever return spring
5	B55504	2	Thrust plate
6	B54172	1	Chassis cover
7	A54190	1	Locking bar
8	B54888	1	Retractor assembly without catchplate
9	A55673	1	Key release cam assembly
10	A55687	1	Keyed sleeve assembly <i>or</i>
not shown	A55725	1	Keyed sleeve assembly <sup>a</sup>
11	D55571	1	Outside hub <i>or</i>
not shown	D56003	1	Outside hub, lost motion
12	A55505	2	Chassis screw

a. For use with non-interchangeable cores.

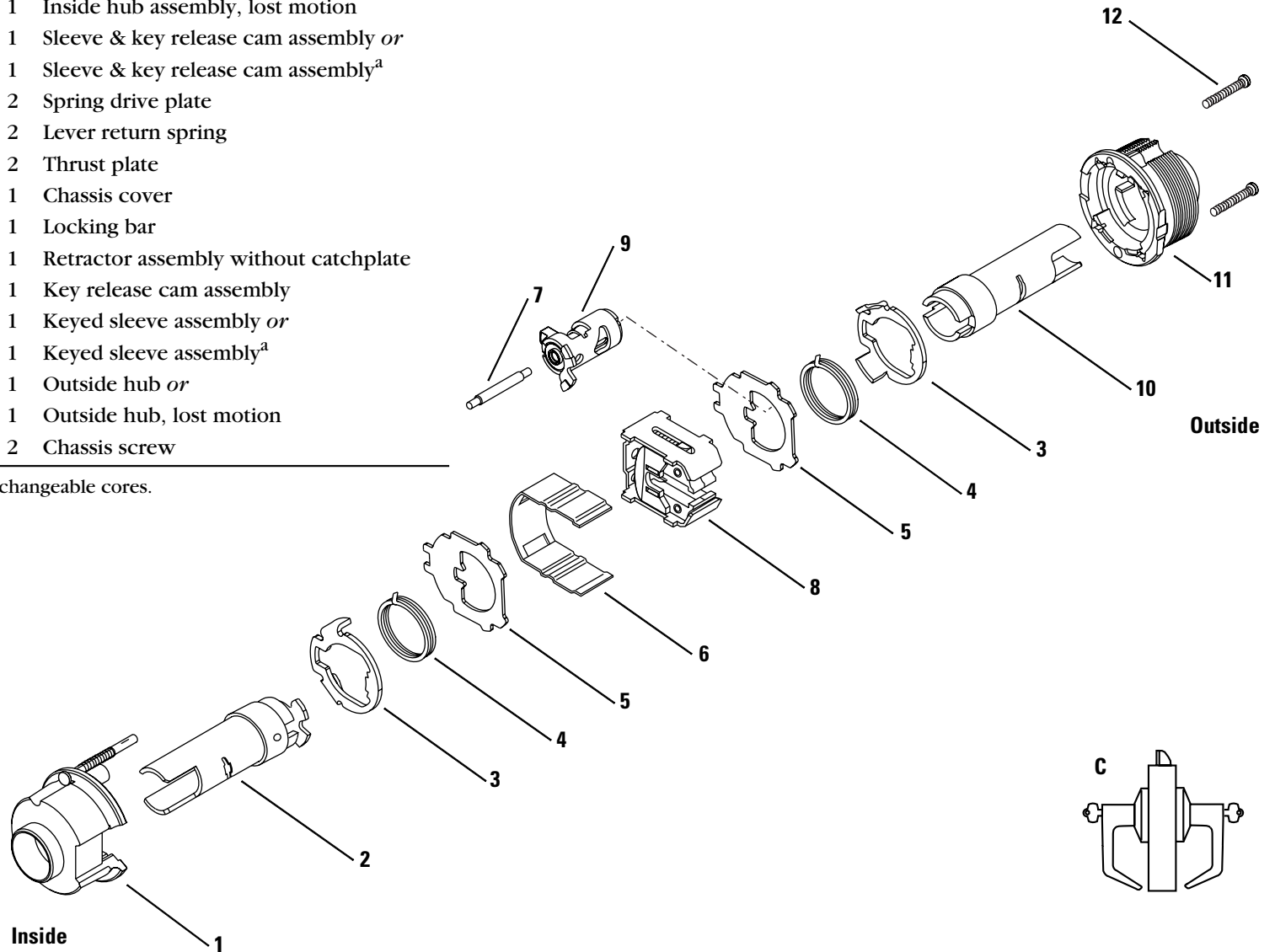
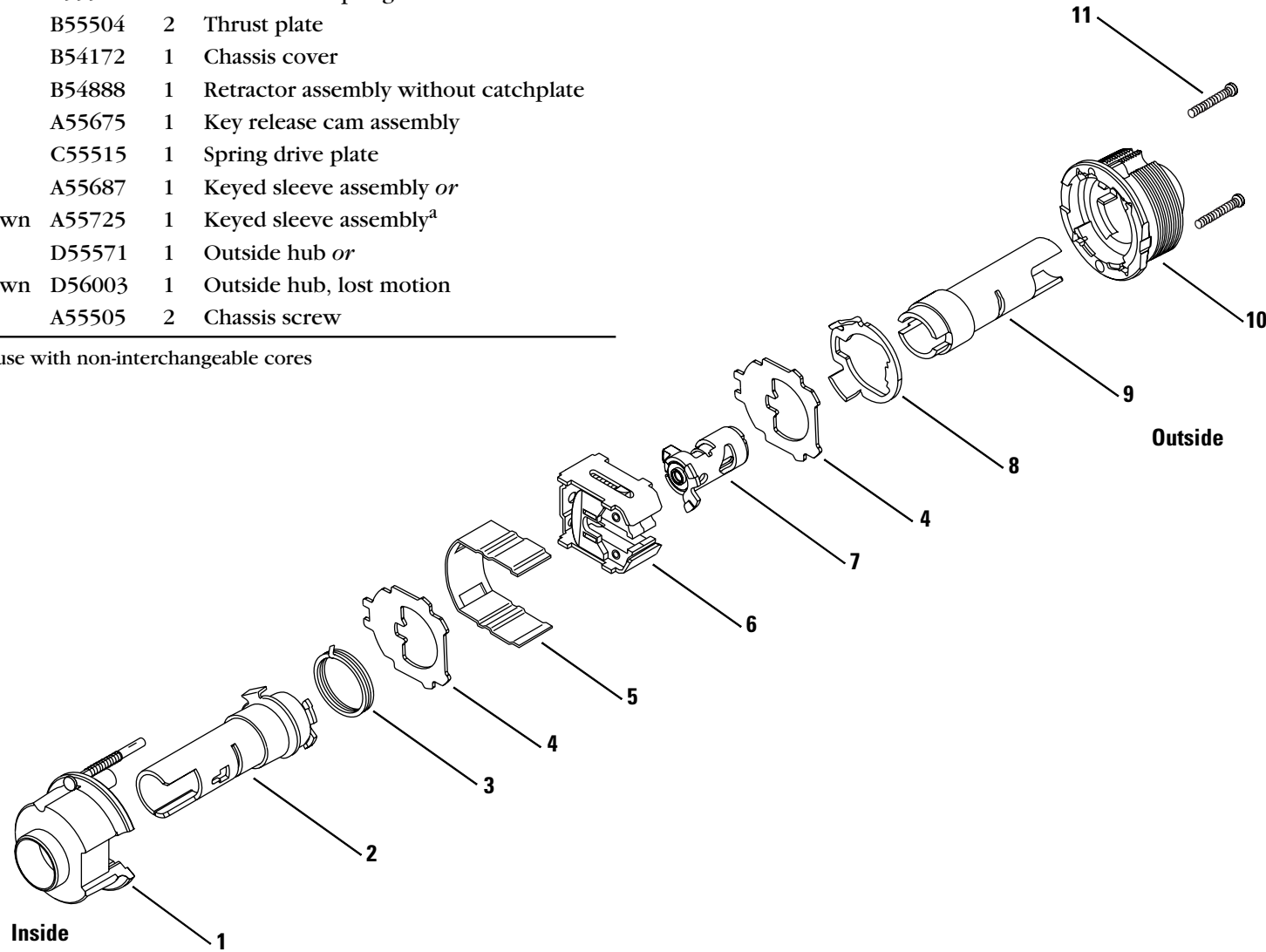

**Figure 2.3** C function exploded diagram

# D FUNCTION CHASSIS—STOREROOM LOCK (ANSI F86)

Item	Part No.	Qty.	Description
1	A55685	1	Inside hub and locking pin assembly
2	B55610	1	Non-keyed sleeve and driver assembly
3	B55518	1	Lever return spring
4	B55504	2	Thrust plate
5	B54172	1	Chassis cover
6	B54888	1	Retractor assembly without catchplate
7	A55675	1	Key release cam assembly
8	C55515	1	Spring drive plate
9	A55687	1	Keyed sleeve assembly <i>or</i>
not shown	A55725	1	Keyed sleeve assembly <sup>a</sup>
10	D55571	1	Outside hub <i>or</i>
not shown	D56003	1	Outside hub, lost motion
11	A55505	2	Chassis screw

a. For use with non-interchangeable cores



**Figure 2.4** D function exploded diagram

## E FUNCTION CHASSIS—SERVICE STATION LOCK (ANSI F92)

Item	Part No.	Qty.	Description
1	B55694	1	Slotted button assembly <sup>a</sup>
2	A55685	1	Inside hub and locking pin assembly
3	B55610	1	Non-keyed sleeve and driver assembly
4	B55518	2	Lever return spring
5	B55504	2	Thrust plate
6	B54172	1	Chassis cover
7	B54886	1	Retractor assembly with long catchplate
8	A55673	1	Key release cam assembly
9	C55515	1	Spring drive plate
10	A55687	1	Keyed sleeve assembly <i>or</i>
not shown	A55725	1	Keyed sleeve assembly <sup>b</sup>
11	D55571	1	Outside hub <i>or</i>
not shown	D56003	1	Outside hub, lost motion
12	A55505	2	Chassis screw

a. Specify finish.

b. For use with non-interchangeable cores.

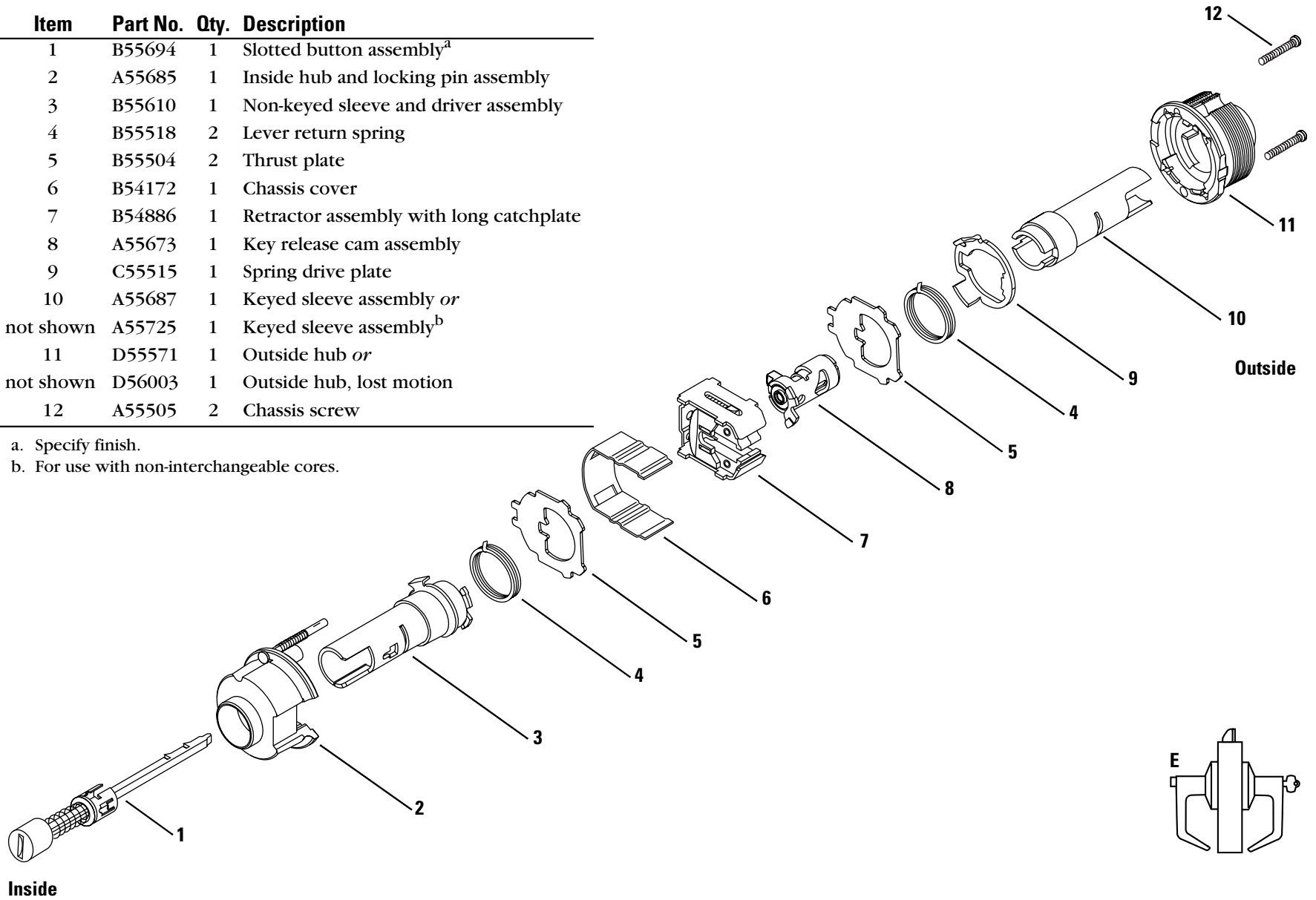

Figure 2.5 E function exploded diagram

# G FUNCTION CHASSIS—STOREROOM LOCK (ANSI F91)

Item	Part No.	Qty.	Description
1	A55685	1	Inside hub and locking pin assembly <i>or</i>
not shown	A56008	1	Inside hub assembly, lost motion
2	A55687	2	Keyed sleeve assembly <i>or</i>
not shown	A55725	2	Keyed sleeve assembly <sup>a</sup>
3	C55515	2	Spring drive plate
4	B55518	2	Lever return spring
5	B55504	2	Thrust plate
6	B54172	1	Chassis cover
7	A55676	2	Key release cam assembly
8	B54888	1	Retractor assembly without catchplate
9	A54195	1	Locking bar
10	D55571	1	Outside hub <i>or</i>
not shown	D56003	1	Outside hub, lost motion
11	A55505	2	Chassis screw

a. For use with non-interchangeable cores.

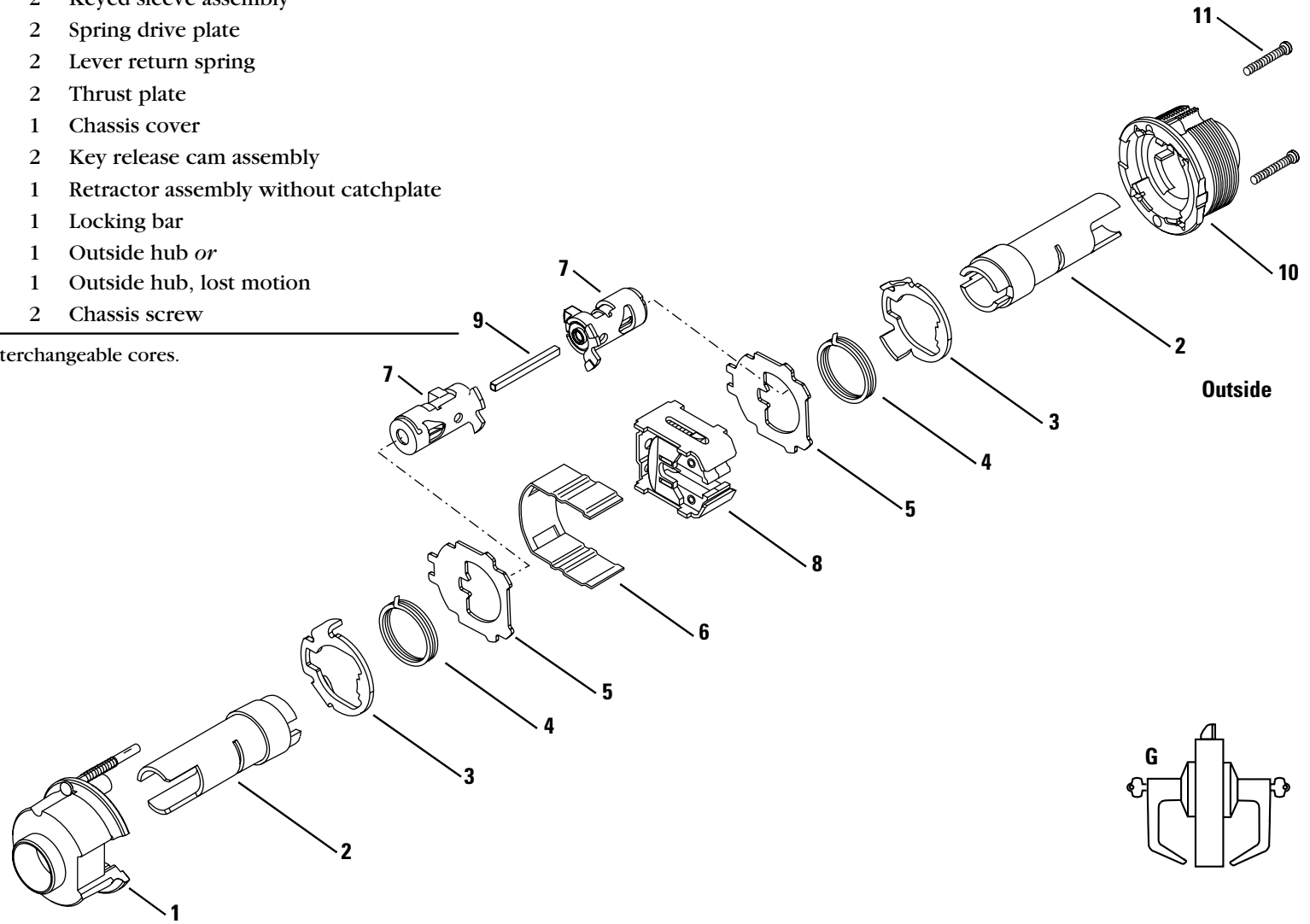
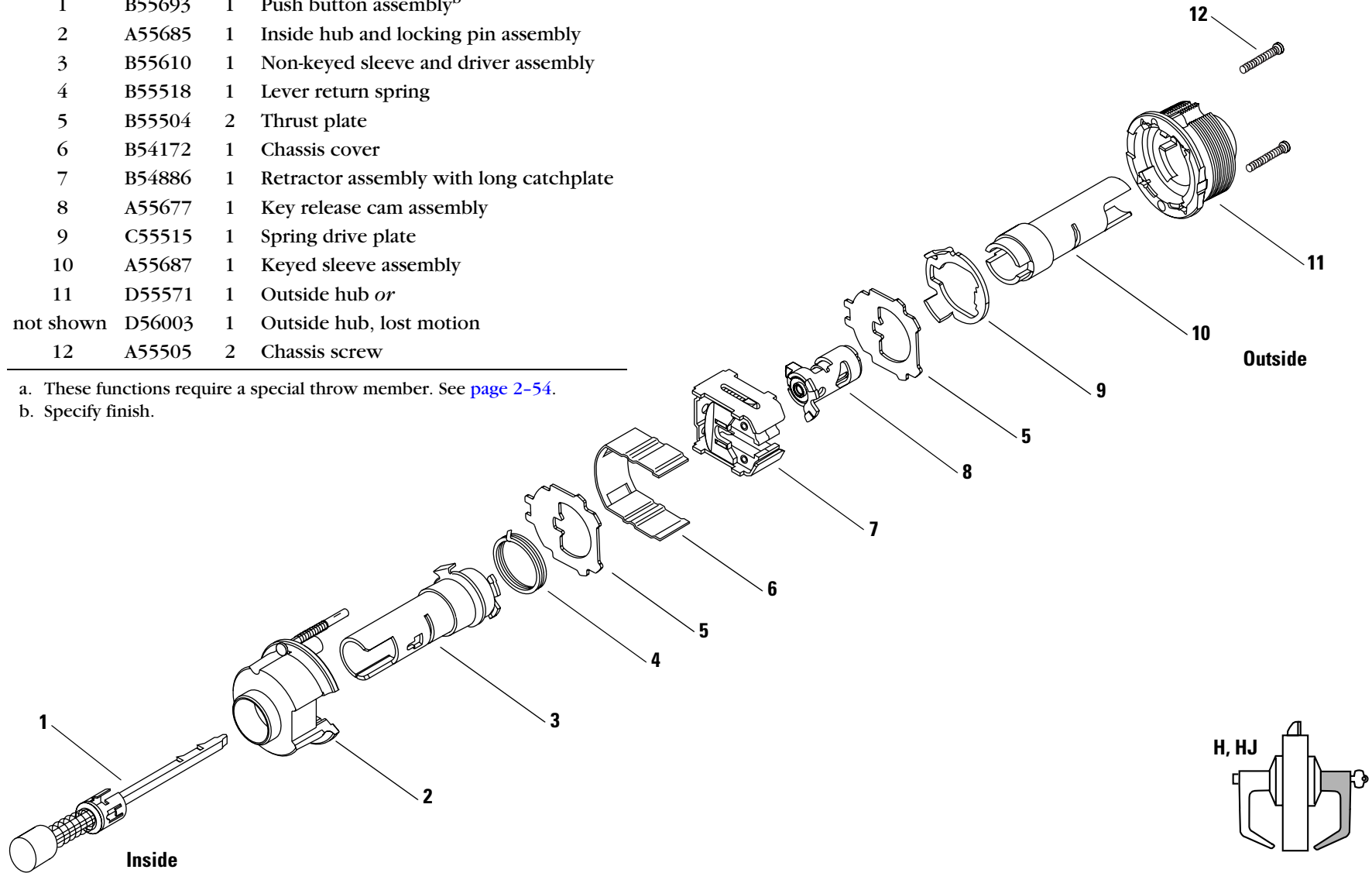

Figure 2.6 G function exploded diagram

## H FUNCTION CHASSIS—HOTEL GUEST ROOM LOCK WITH INDICATOR (ANSI F93) HJ FUNCTION CHASSIS—HOTEL GUEST ROOM LOCK WITHOUT INDICATOR

Item <sup>a</sup>	Part No.	Qty.	Description
1	B55693	1	Push button assembly <sup>b</sup>
2	A55685	1	Inside hub and locking pin assembly
3	B55610	1	Non-keyed sleeve and driver assembly
4	B55518	1	Lever return spring
5	B55504	2	Thrust plate
6	B54172	1	Chassis cover
7	B54886	1	Retractor assembly with long catchplate
8	A55677	1	Key release cam assembly
9	C55515	1	Spring drive plate
10	A55687	1	Keyed sleeve assembly
11	D55571	1	Outside hub <i>or</i>
not shown	D56003	1	Outside hub, lost motion
12	A55505	2	Chassis screw

- a. These functions require a special throw member. See [page 2-54](#).  
b. Specify finish.

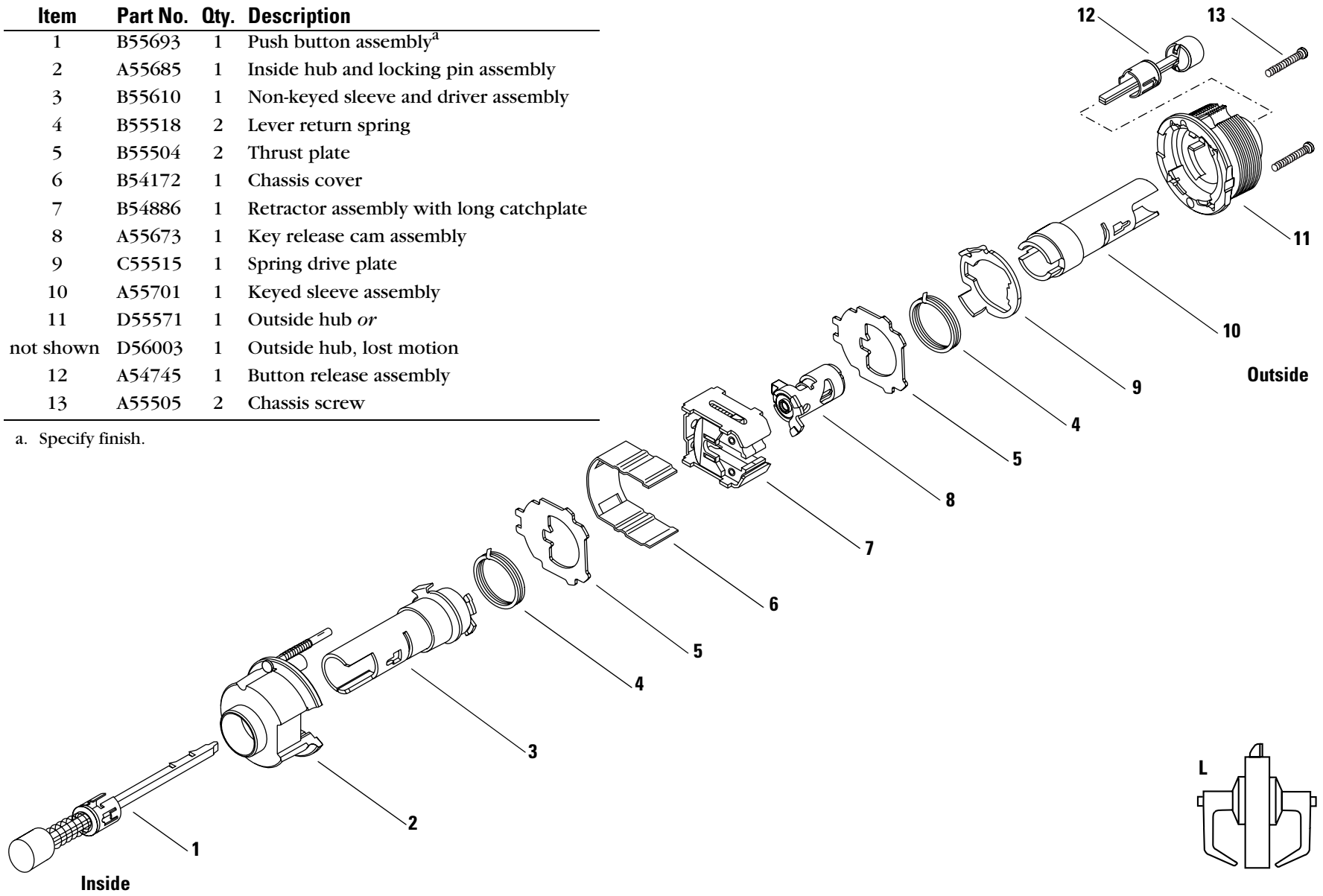

**Figure 2.7** H/HJ function exploded diagram

# L FUNCTION CHASSIS—PRIVACY LOCK (ANSI F76)

Item	Part No.	Qty.	Description
1	B55693	1	Push button assembly <sup>a</sup>
2	A55685	1	Inside hub and locking pin assembly
3	B55610	1	Non-keyed sleeve and driver assembly
4	B55518	2	Lever return spring
5	B55504	2	Thrust plate
6	B54172	1	Chassis cover
7	B54886	1	Retractor assembly with long catchplate
8	A55673	1	Key release cam assembly
9	C55515	1	Spring drive plate
10	A55701	1	Keyed sleeve assembly
11	D55571	1	Outside hub <i>or</i>
not shown	D56003	1	Outside hub, lost motion
12	A54745	1	Button release assembly
13	A55505	2	Chassis screw

a. Specify finish.



**Figure 2.8** L function exploded diagram

## N FUNCTION CHASSIS—PASSAGE LOCK (ANSI F75)

Item	Part No.	Qty.	Description
1	A55685	1	Inside hub and locking pin assembly
2	B55610	2	Non-keyed sleeve and driver assembly
3	B55518	2	Lever return spring
4	B55504	2	Thrust plate
5	B54172	1	Chassis cover
6	B54888	1	Retractor assembly without catchplate
7	D55571	1	Outside hub
8	A55505	2	Chassis screw

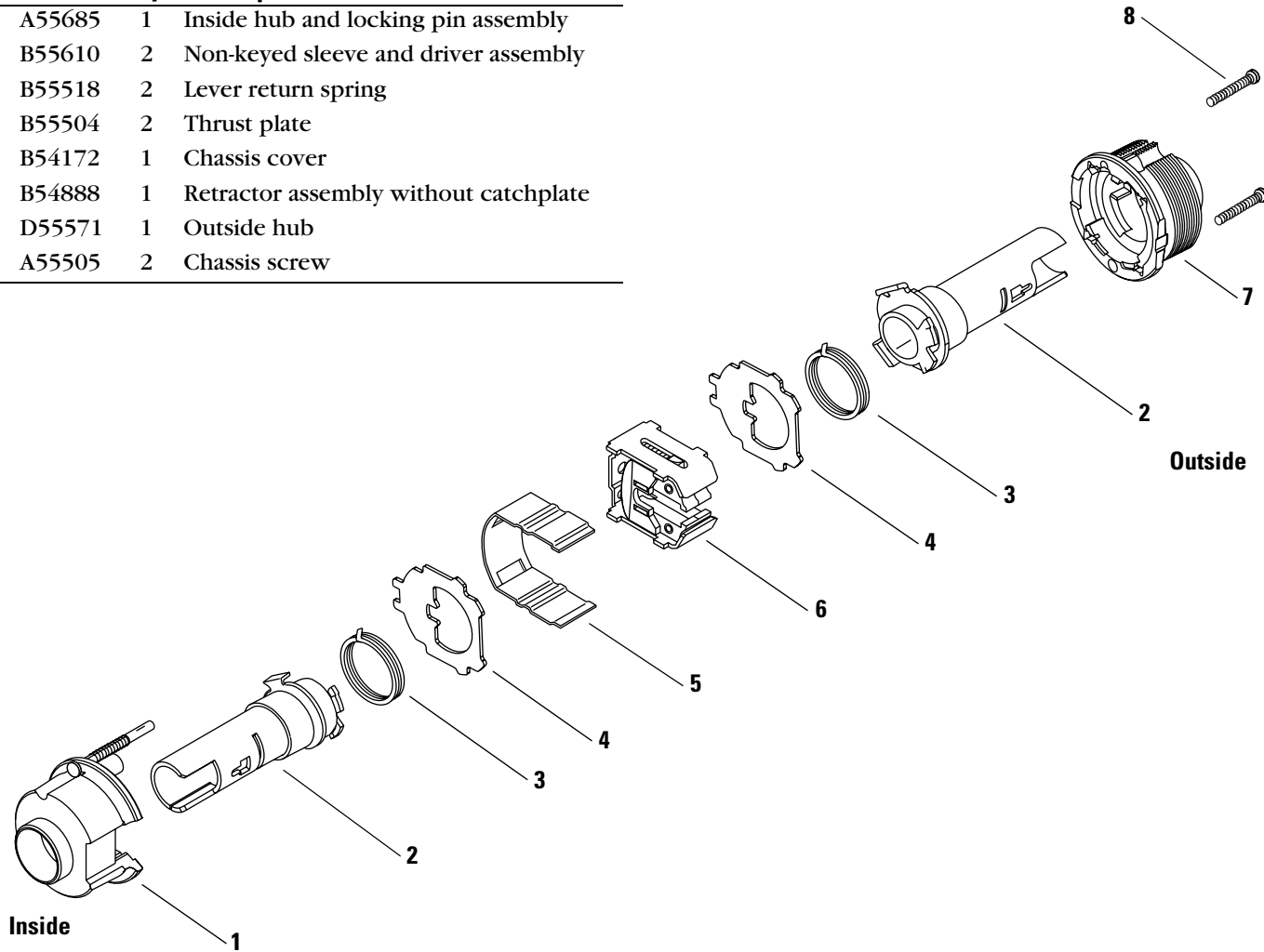
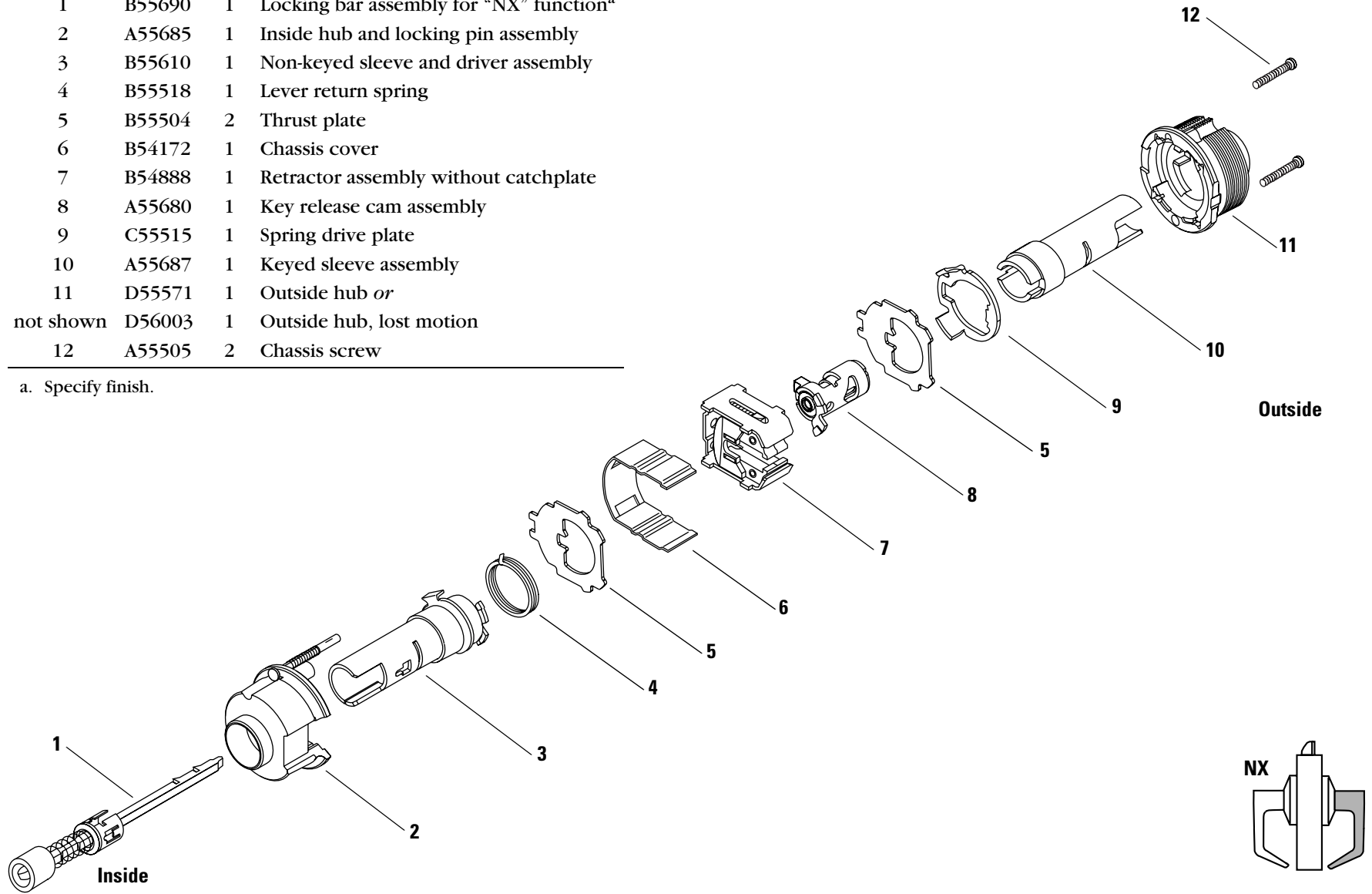

Figure 2.9 N function exploded diagram

# NX FUNCTION CHASSIS—EXIT LOCK (ANSI F89)

Item	Part No.	Qty.	Description
1	B55690	1	Locking bar assembly for “NX” function <sup>a</sup>
2	A55685	1	Inside hub and locking pin assembly
3	B55610	1	Non-keyed sleeve and driver assembly
4	B55518	1	Lever return spring
5	B55504	2	Thrust plate
6	B54172	1	Chassis cover
7	B54888	1	Retractor assembly without catchplate
8	A55680	1	Key release cam assembly
9	C55515	1	Spring drive plate
10	A55687	1	Keyed sleeve assembly
11	D55571	1	Outside hub <i>or</i>
not shown	D56003	1	Outside hub, lost motion
12	A55505	2	Chassis screw

a. Specify finish.



**Figure 2.10** NX function exploded diagram



## P FUNCTION CHASSIS—PATIO LOCK (ANSI F77)

Item	Part No.	Qty.	Description
1	B55693	1	Push button assembly <sup>a</sup>
2	A55685	1	Inside hub and locking pin assembly
3	B55610	1	Non-keyed sleeve and driver assembly
4	B55518	2	Lever return spring
5	B55504	2	Thrust plate
6	B54172	1	Chassis cover
7	B54886	1	Retractor assembly with long catchplate
8	A55680	1	Key release cam assembly
9	C55515	1	Spring drive plate
10	A55687	1	Keyed sleeve assembly
11	D55571	1	Outside hub <i>or</i>
not shown	D56003	1	Outside hub, lost motion
12	A55505	2	Chassis screw

a. Specify finish.

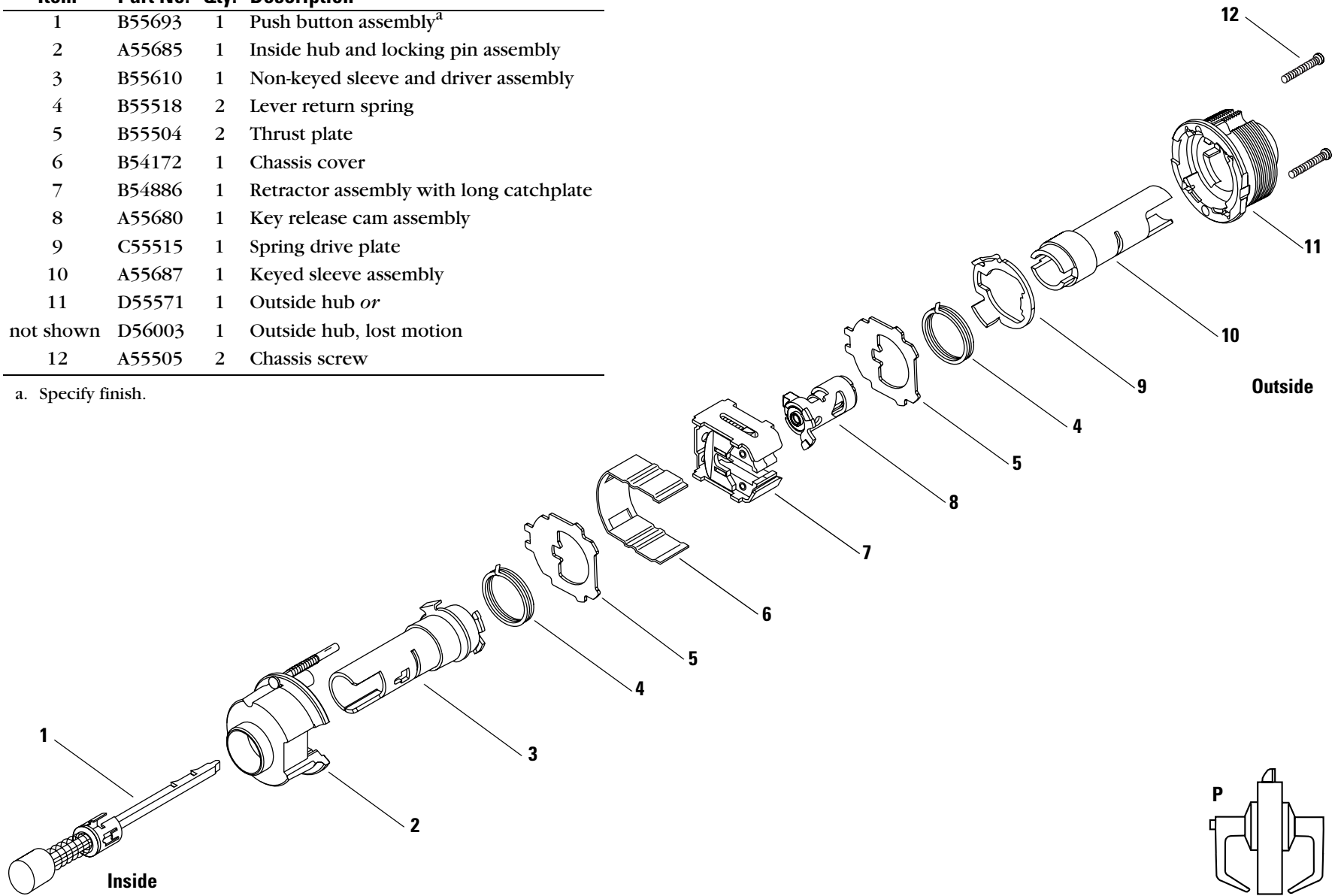

**Figure 2.11** P function exploded diagram

# R FUNCTION CHASSIS—CLASSROOM LOCK (ANSI F84)

Item	Part No.	Qty.	Description
1	A55685	1	Inside hub and locking pin assembly
2	B55610	1	Non-keyed sleeve and driver assembly
3	B55518	2	Lever return spring
4	B55504	2	Thrust plate
5	B54172	1	Chassis cover
6	B54888	1	Retractor assembly without catchplate
7	A55681	1	Key release cam assembly
8	C55515	1	Spring drive plate
9	A55687	1	Keyed sleeve assembly <i>or</i>
not shown	A55725	1	Keyed sleeve assembly <sup>a</sup>
10	D55571	1	Outside hub <i>or</i>
not shown	D56003	1	Outside hub, lost motion
11	A55505	2	Chassis screw

a. For use with non-interchangeable cores.

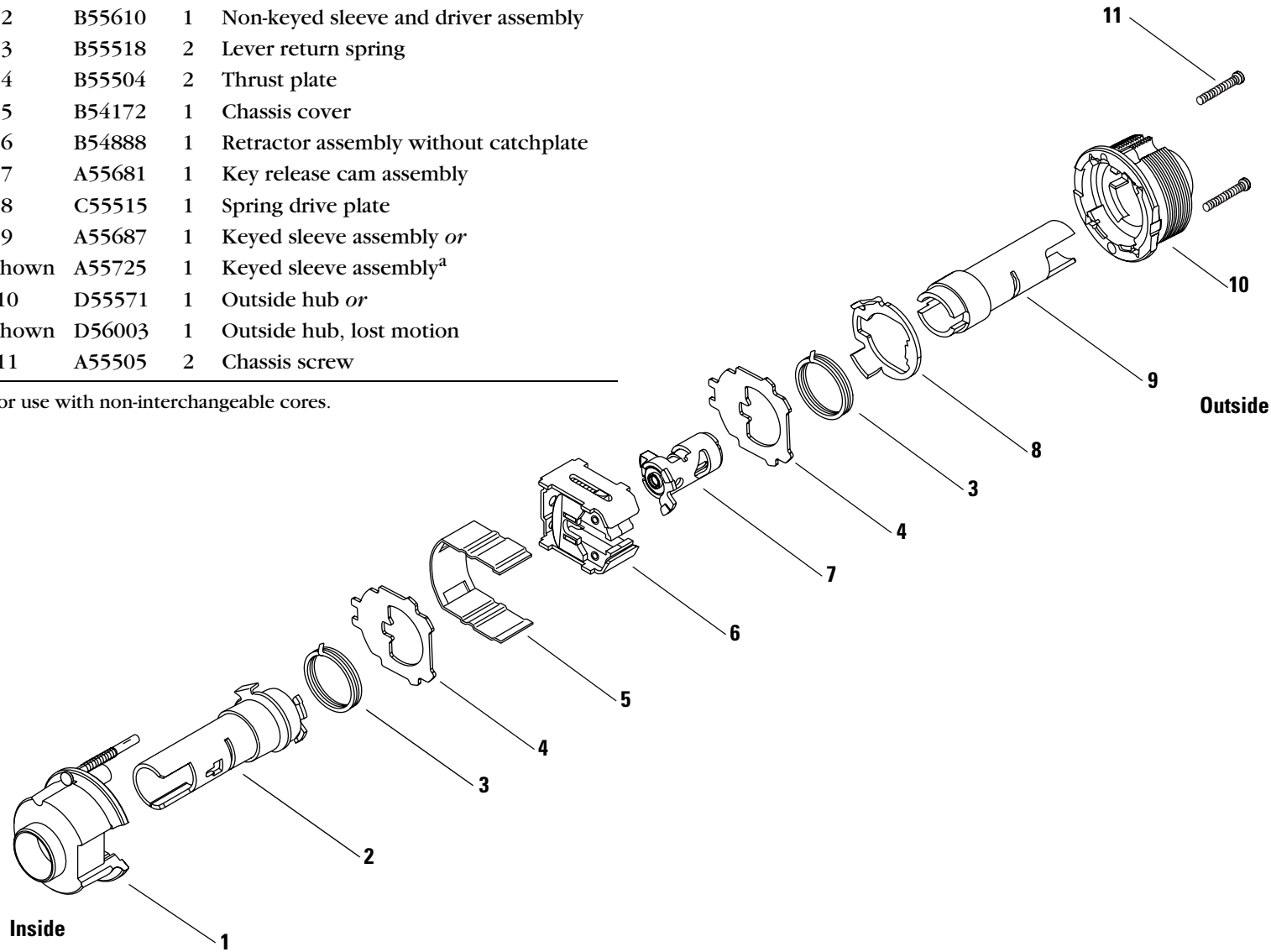

Figure 2.12 R function exploded diagram

# S FUNCTION CHASSIS—COMMUNICATING LOCK (ANSI F80)

Item	Part No.	Qty.	Description
1	A55685	1	Inside hub and locking pin assembly <i>or</i>
not shown	A56008	1	Inside hub assembly, lost motion
2	A55687	2	Keyed sleeve assembly <i>or</i>
not shown	A55725	2	Keyed sleeve assembly <sup>a</sup>
3	C55515	2	Spring drive plate
4	B55518	2	Lever return spring
5	B55504	2	Thrust plate
6	A55681	2	Key release cam assembly
7	B54172	1	Chassis cover
8	B54888	1	Retractor assembly without catchplate
9	D55571	1	Outside hub <i>or</i>
not shown	D56003	1	Outside hub, lost motion
10	A55505	2	Chassis screw

a. For use with non-interchangeable cores.

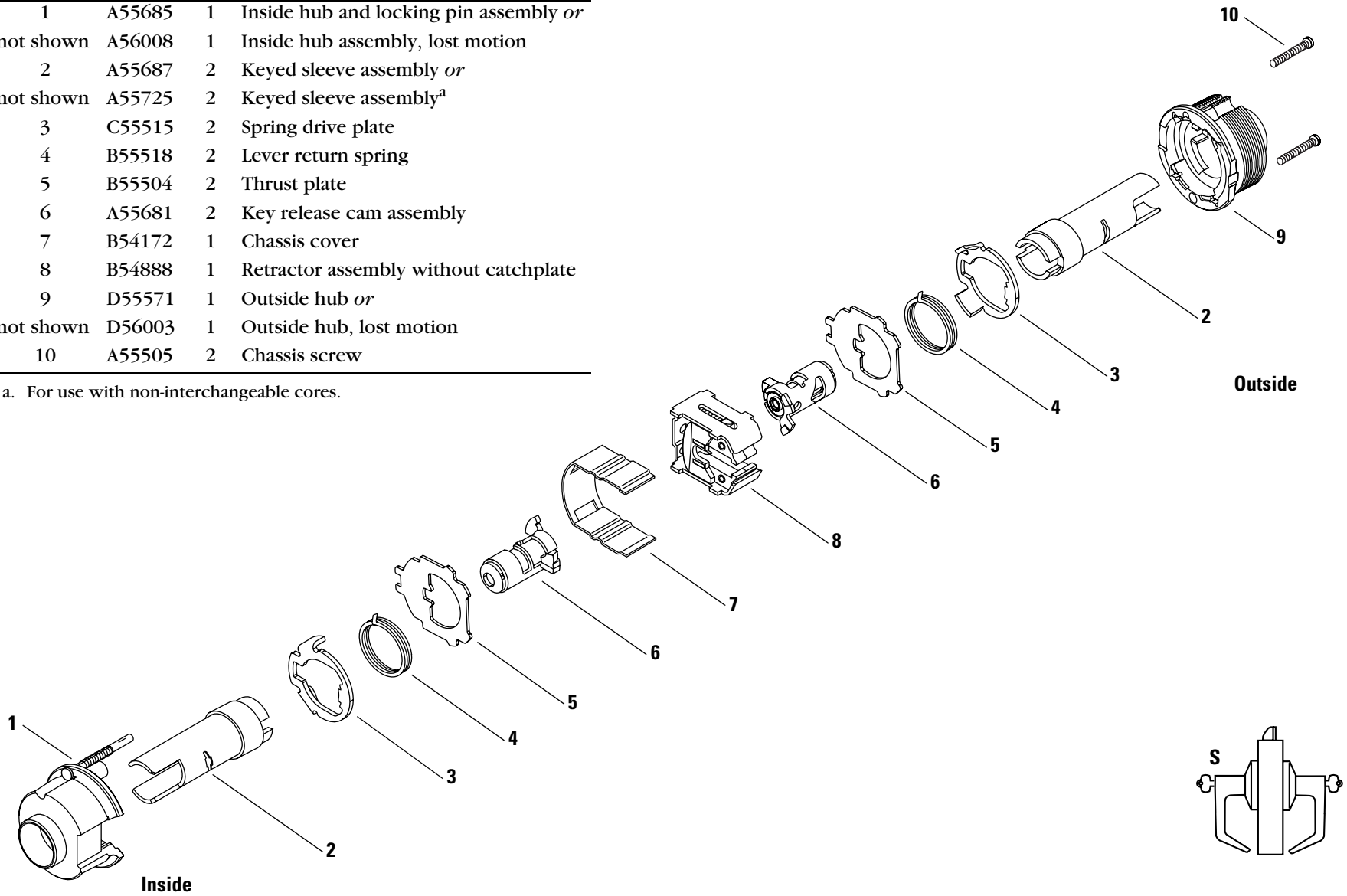

Figure 2.13 S function exploded diagram

# T FUNCTION CHASSIS—DORMITORY LOCK (ANSI F90)

Item	Part No.	Qty.	Description
1	B55693	1	Push button assembly <sup>a</sup>
2	A55685	1	Inside hub and locking pin assembly
3	B55610	1	Non-keyed sleeve and driver assembly
4	B55518	2	Lever return spring
5	B55504	2	Thrust plate
6	B54172	1	Chassis cover
7	B54886	1	Retractor assembly with long catchplate
8	A55681	1	Key release cam assembly
9	C55515	1	Spring drive plate
10	A55687	1	Keyed sleeve assembly <i>or</i>
not shown	A55725	1	Keyed sleeve assembly <sup>b</sup>
11	D55571	1	Outside hub <i>or</i>
not shown	D56003	1	Outside hub, lost motion
12	A55505	2	Chassis screw

a. Specify finish.

b. For use with non-interchangeable cores.

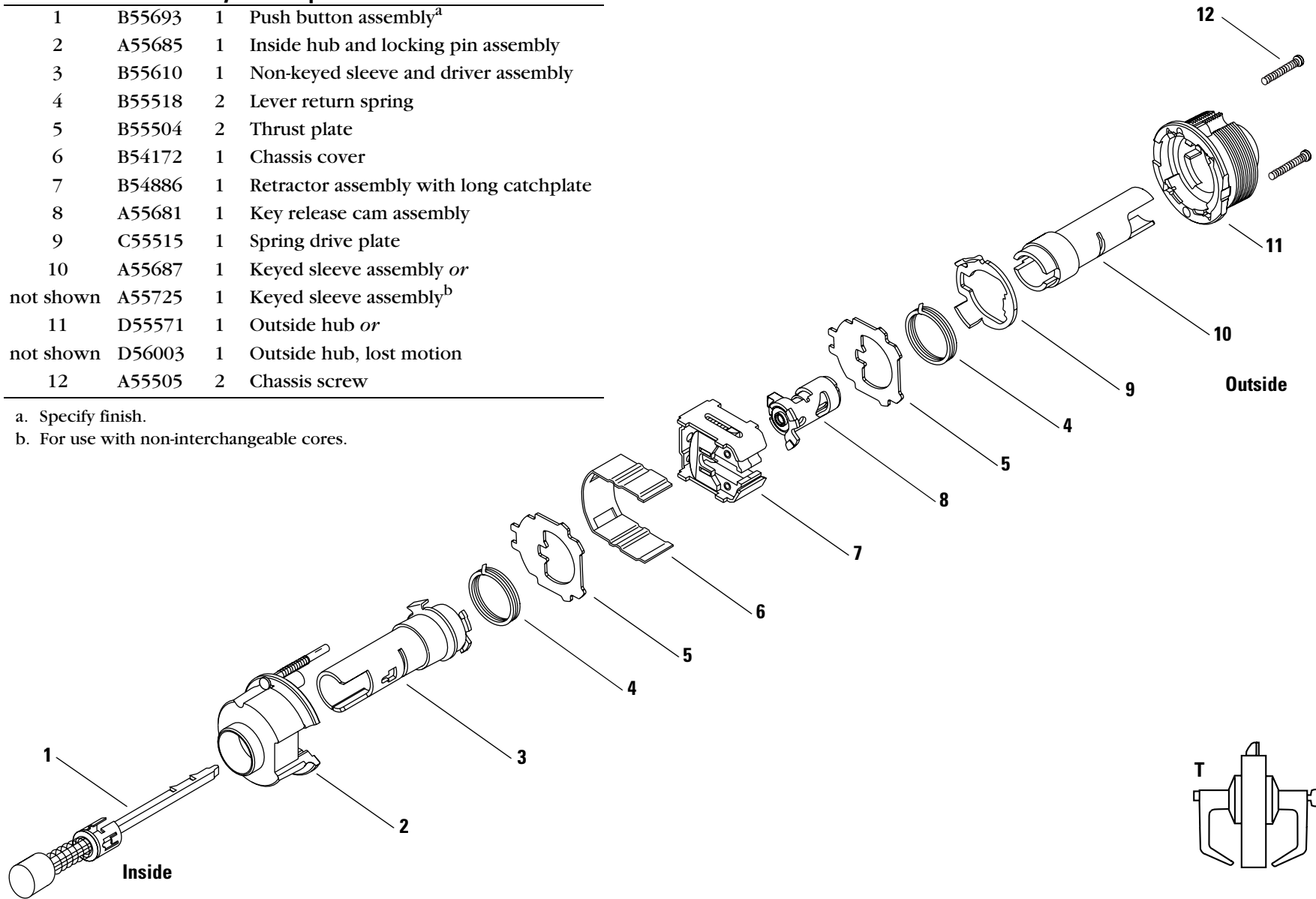
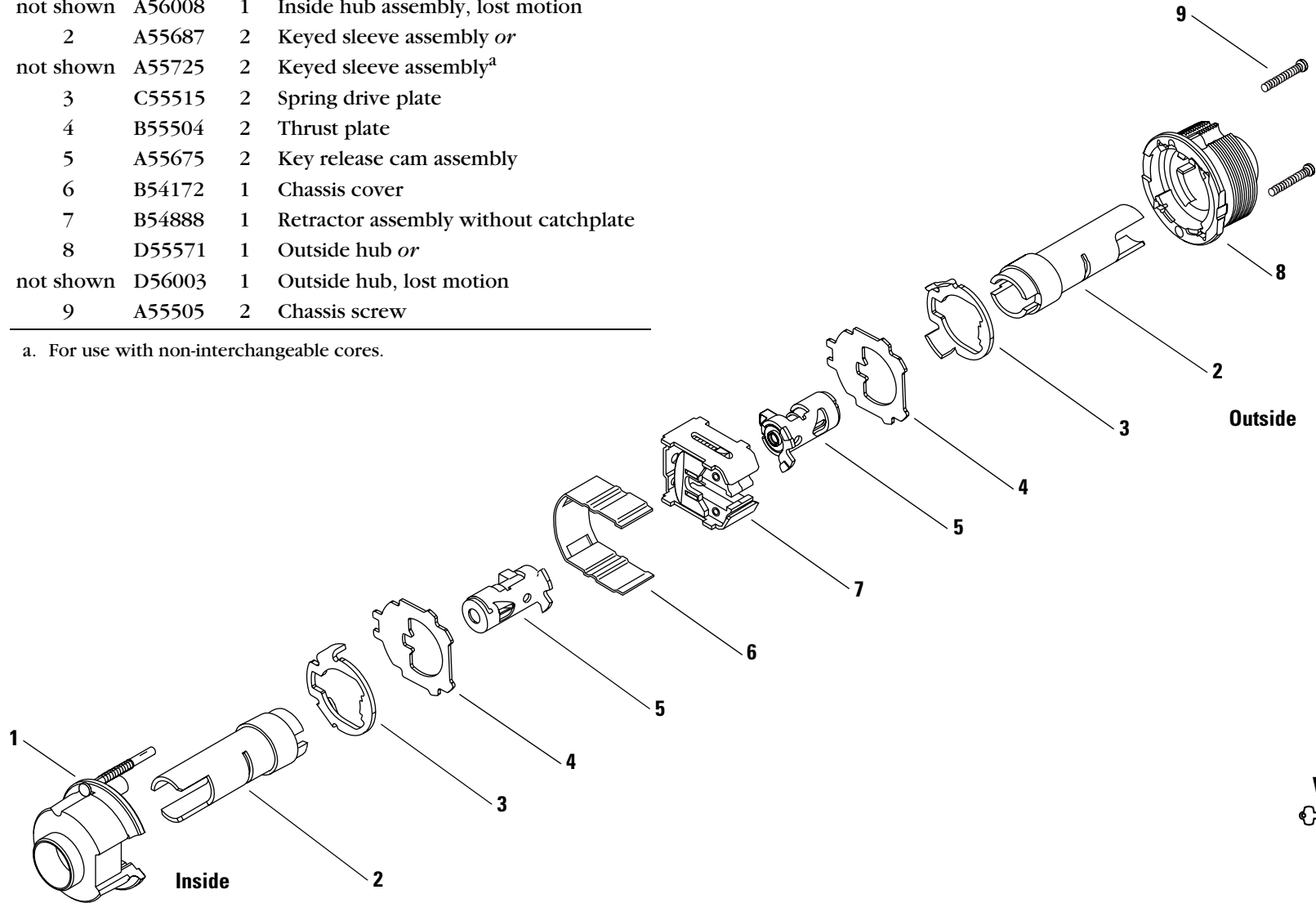

**Figure 2.14** T function exploded diagram

## W FUNCTION CHASSIS—UTILITY OR INSTITUTIONAL LOCK (ANSI F87)

Item	Part No.	Qty.	Description
1	A55685	1	Inside hub and locking pin assembly <i>or</i>
not shown	A56008	1	Inside hub assembly, lost motion
2	A55687	2	Keyed sleeve assembly <i>or</i>
not shown	A55725	2	Keyed sleeve assembly <sup>a</sup>
3	C55515	2	Spring drive plate
4	B55504	2	Thrust plate
5	A55675	2	Key release cam assembly
6	B54172	1	Chassis cover
7	B54888	1	Retractor assembly without catchplate
8	D55571	1	Outside hub <i>or</i>
not shown	D56003	1	Outside hub, lost motion
9	A55505	2	Chassis screw

a. For use with non-interchangeable cores.



**Figure 2.15** W function exploded diagram

# Y FUNCTION CHASSIS—EXIT LOCK

Item	Part No.	Qty.	Description
1	A55685	1	Inside hub and locking pin assembly
2	B55610	1	Non-keyed sleeve and driver assembly
3	B55518	1	Lever return spring
4	B55504	1	Thrust plate
5	B54172	1	Chassis cover
6	B54888	1	Retractor assembly without catchplate
7	B54809	1	Outside hub and plate assembly
8	A55511	2	Chassis screw

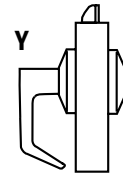
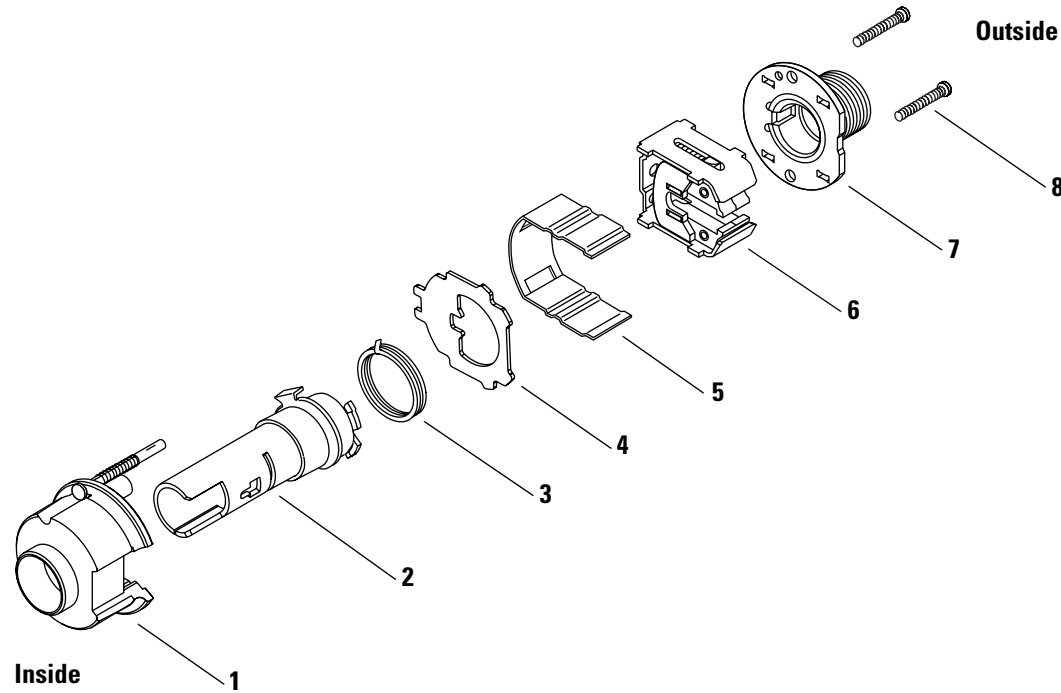

**Figure 2.16** Y function exploded diagram

## NON-STANDARD FUNCTIONS

### A FUNCTION CHASSIS—ENTRANCE LOCK (ANSI F81)

Item	Part No.	Qty.	Description
1	B55692	1	Turn button assembly <sup>a</sup>
2	A55685	1	Inside hub and locking pin assembly
3	B55610	1	Non-keyed sleeve and driver assembly
4	B55518	2	Lever return spring
5	B55504	2	Thrust plate
6	B54172	1	Chassis cover
7	B54888	1	Retractor assembly without catchplate
8	A55673	1	Key release cam assembly
9	C55515	1	Spring drive plate
10	A55687	1	Keyed sleeve assembly <i>or</i>
not shown	A55725	1	Keyed sleeve assembly <sup>b</sup>
11	D55571	1	Outside hub <i>or</i>
not shown	D56003	1	Outside hub, lost motion
12	A55505	2	Chassis screw

a. Specify finish.

b. For use with non-interchangeable cores.

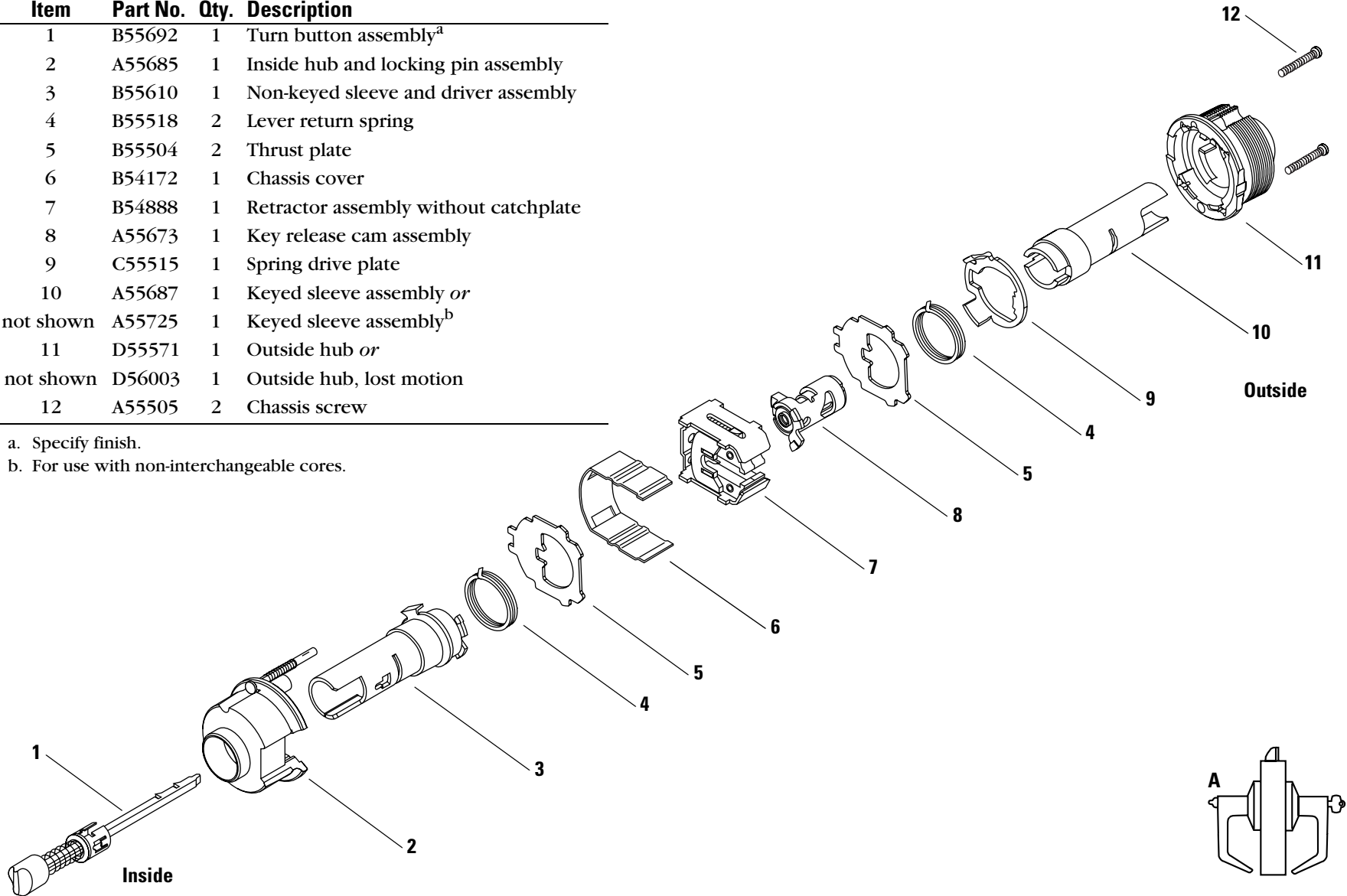

**Figure 2.17** A function exploded diagram

# B FUNCTION CHASSIS—OFFICE LOCK (ANSI F82)

Item	Part No.	Qty.	Description
1	B55693	1	Push button assembly <sup>a</sup>
2	A55685	1	Inside hub and locking pin assembly
3	B55610	1	Non-keyed sleeve and driver assembly
4	B55518	2	Lever return spring
5	B55504	2	Thrust plate
6	B54172	1	Chassis cover
7	B54887	1	Retractor assembly with short catchplate
8	A55673	1	Key release cam assembly
9	C55515	1	Spring drive plate
10	A55687	1	Keyed sleeve assembly <i>or</i>
not shown	A55725	1	Keyed sleeve assembly <sup>b</sup>
11	D55571	1	Outside hub <i>or</i>
not shown	D56003	1	Outside hub, lost motion
12	A55505	2	Chassis screw

a. Specify finish.

b. For use with non-interchangeable cores.

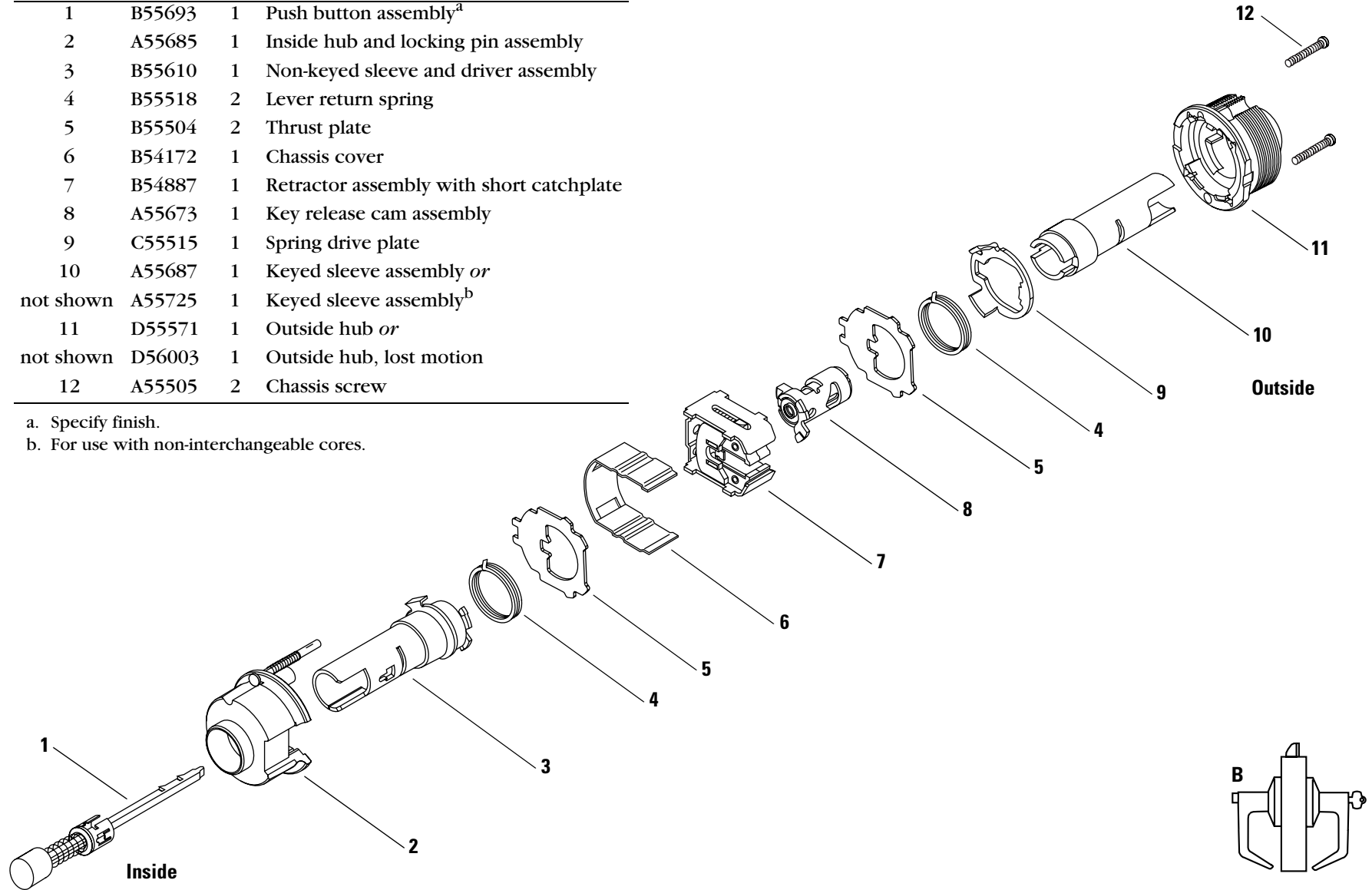

**Figure 2.18** B function exploded diagram



# DR FUNCTION CHASSIS—SPECIAL LOCK

Item	Part No.	Qty.	Description
1	A55685	1	Inside hub, and locking pin assembly <i>or</i>
not shown	A56008	1	Inside hub assembly, lost motion
2	A55687	2	Keyed sleeve assembly <i>or</i>
not shown	A55725	2	Keyed sleeve assembly <sup>a</sup>
3	C55515	2	Spring drive plate
4	B55518	1	Lever return spring
5	B55504	2	Thrust plate
6	A55681	1	Key release cam assembly
7	B54172	1	Chassis cover
8	B54888	1	Retractor assembly without catchplate
9	A55675	1	Key release cam assembly
10	D55571	1	Outside hub <i>or</i>
not shown	D56003	1	Outside hub, lost motion
11	A55505	2	Chassis screw

a. For use with non-interchangeable cores.

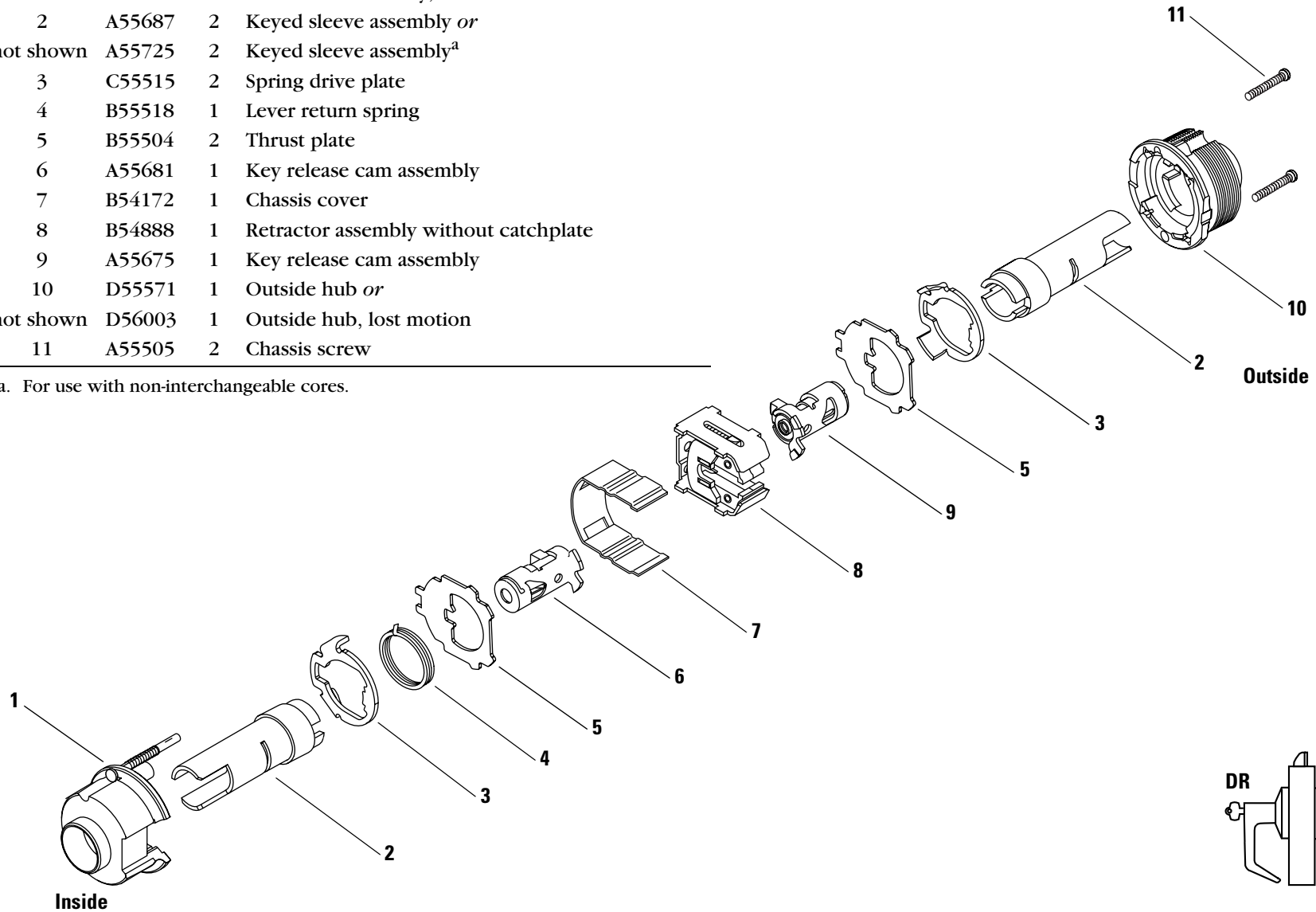

Figure 2.19 DR function exploded diagram

# DZ FUNCTION CHASSIS—CLOSET OR STOREROOM LOCK

Item	Part No.	Qty.	Description
1	A54736	1	Turn blade assembly for Z function <sup>a</sup>
2	B54810	1	Inside hub and side plate assembly
3	A54835	1	Non-keyed sleeve and driver assembly
4	B54172	1	Chassis cover
5	B54888	1	Retractor assembly without catchplate
6	A55675	1	Key release cam assembly
7	B55504	1	Thrust plate
8	C55515	1	Spring drive plate
9	A55687	1	Keyed sleeve assembly <i>or</i>
not shown	A55725	1	Keyed sleeve assembly <sup>b</sup>
10	D55571	1	Outside hub <i>or</i>
not shown	D56003	1	Outside hub, lost motion
11	A55511	2	Chassis screw

a. Specify finish.

b. For use with non-interchangeable cores.

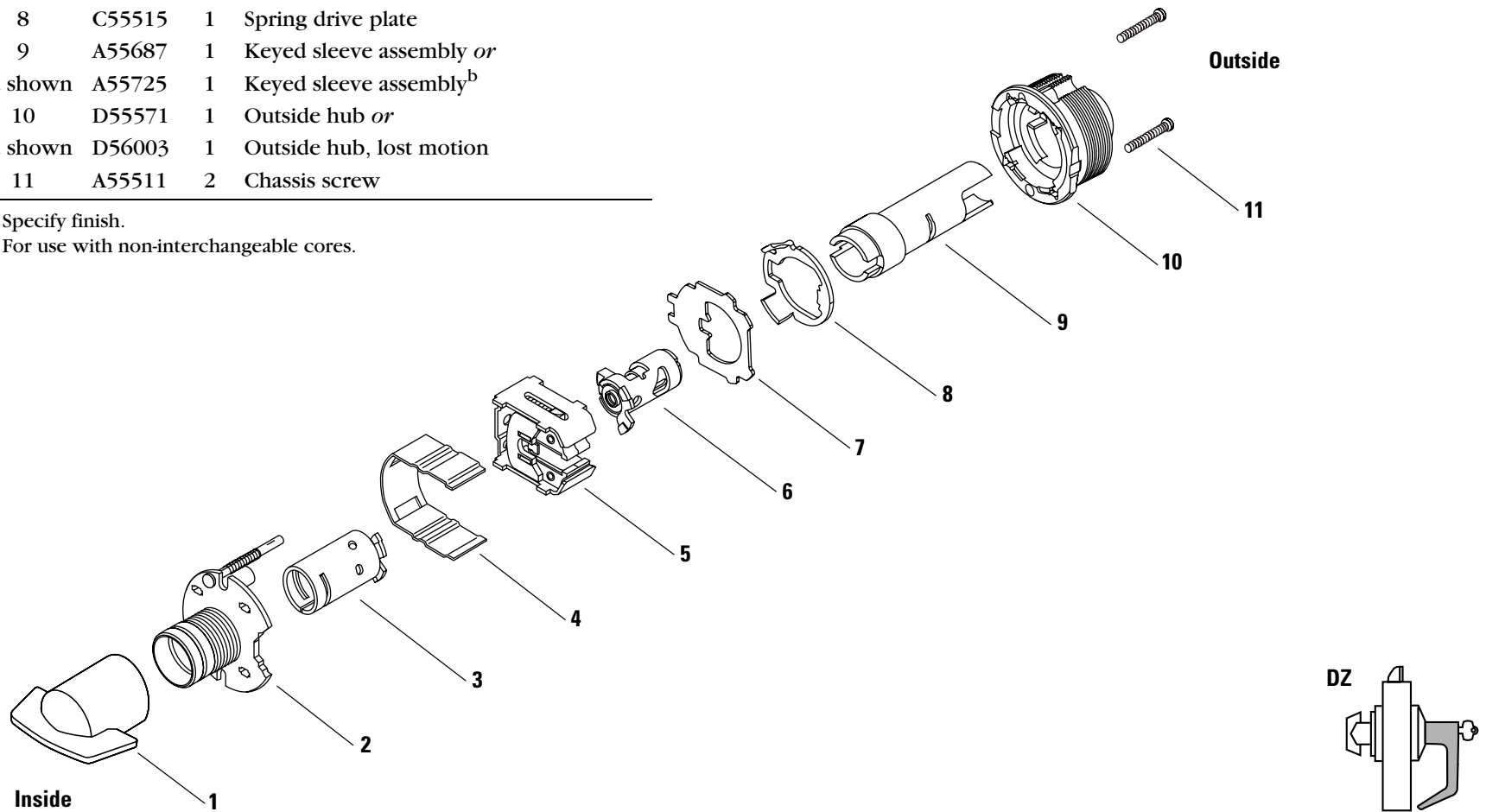

**Figure 2.20** DZ function exploded diagram

# EA FUNCTION CHASSIS—ENTRANCE OR OFFICE LOCK

Item	Part No.	Qty.	Description
1	B55694	1	Slotted button assembly <sup>a</sup>
2	A55685	1	Inside hub and locking pin assembly
3	B55610	1	Non-keyed sleeve and driver assembly
4	B55518	2	Lever return spring
5	B55504	2	Thrust plate
6	B54172	1	Chassis cover
7	B54887	1	Retractor assembly with short catchplate
8	A55673	1	Key release cam assembly
9	C55515	1	Spring drive plate
10	A55687	1	Keyed sleeve assembly <i>or</i>
not shown	A55725	1	Keyed sleeve assembly <sup>b</sup>
11	D55571	1	Outside hub <i>or</i>
not shown	D56003	1	Outside hub, lost motion
12	A55505	2	Chassis screw

a. Specify finish.

b. For use with non-interchangeable cores.

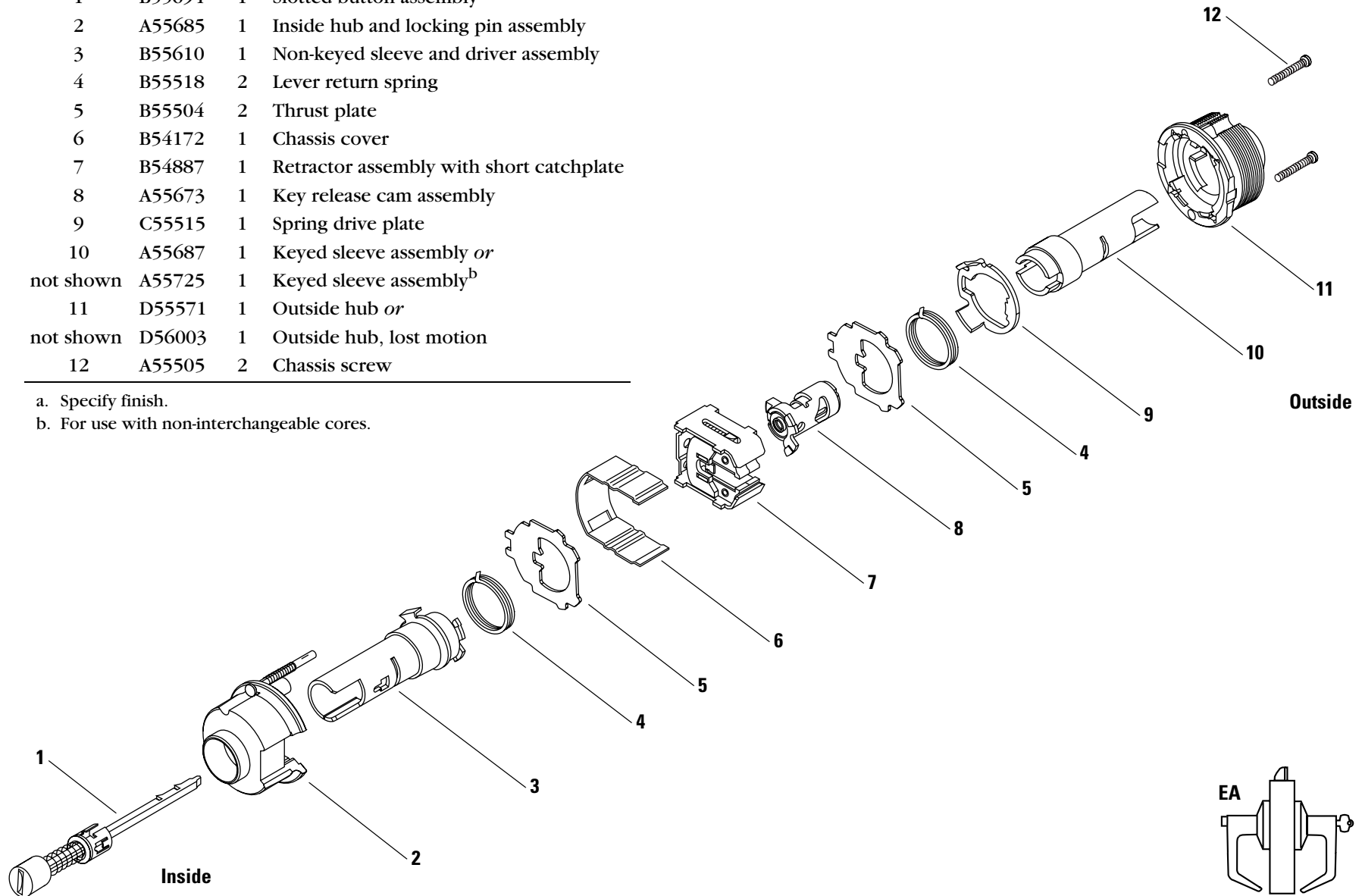

**Figure 2.21** EA function exploded diagram

# IN FUNCTION CHASSIS—INTRUDER LOCK

Item	Part No.	Qty.	Description
1	A55685	1	Inside hub and locking pin assembly <i>or</i>
not shown	A56008	1	Inside hub and locking pin assembly, lost motion
2	A55687	2	Keyed sleeve assembly <i>or</i>
not shown	A55725	2	Keyed sleeve assembly <sup>a</sup>
3	C55515	2	Spring drive plate
4	B55518	2	Lever return spring
5	B55504	2	Thrust plate
6	A56038	1	Key release cam assembly
7	B54172	1	Chassis cover
8	A54195	1	Locking bar
9	B54888	1	Retractor assembly without catchplate
10	A55676	1	Key release cam assembly
11	D55571	1	Outside hub <i>or</i>
not shown	D56003	1	Outside hub, lost motion
12	A55505	2	Chassis screw

a. For use with non-interchangeable cores.

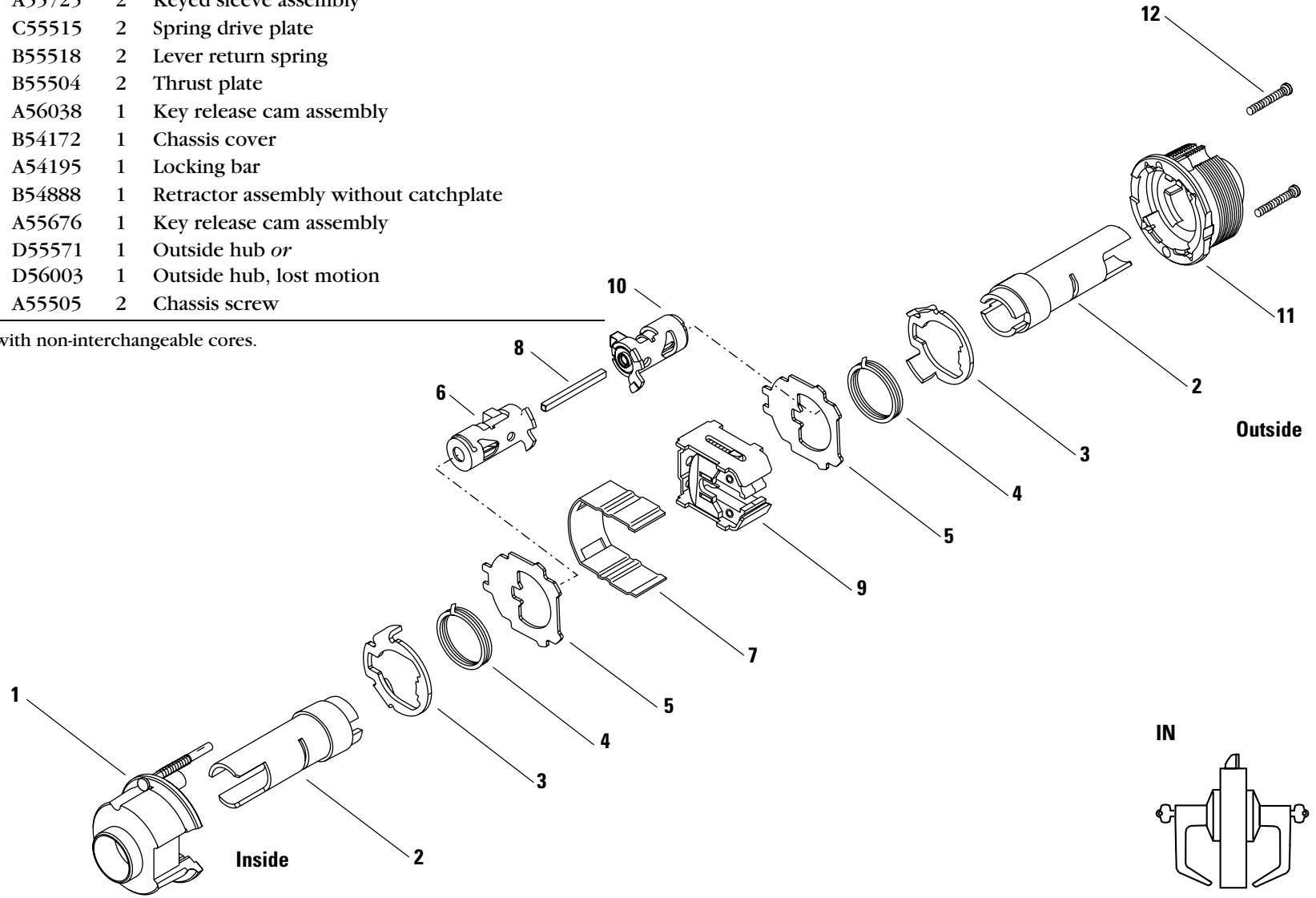

Figure 2.22 IN function exploded diagram

# LL FUNCTION CHASSIS—HOSPITAL PRIVACY LOCK

Item	Part No.	Qty.	Description
1	B55693	1	Push button assembly <sup>a</sup>
2	A55685	1	Inside hub and locking pin assembly
3	B55610	1	Non-keyed sleeve and driver assembly
4	B55518	2	Lever return spring
5	B55504	2	Thrust plate
6	B54172	1	Chassis cover
7	B54886	1	Retractor assembly with long catchplate
8	A55673	1	Key release cam assembly
9	C55515	1	Spring drive plate
10	A55701	1	Keyed sleeve assembly for "M" function
11	D55571	1	Outside hub <i>or</i>
not shown	D56003	1	Outside hub, lost motion
12	B54210	1	6 Pin throw member
13	A55699	1	Outside button assembly for "LL" function <sup>b</sup>
14	A55505	2	Chassis screw

a. Specify finish.

b. Fits into the button lever, not shown. See [page 2-54](#) for button levers.

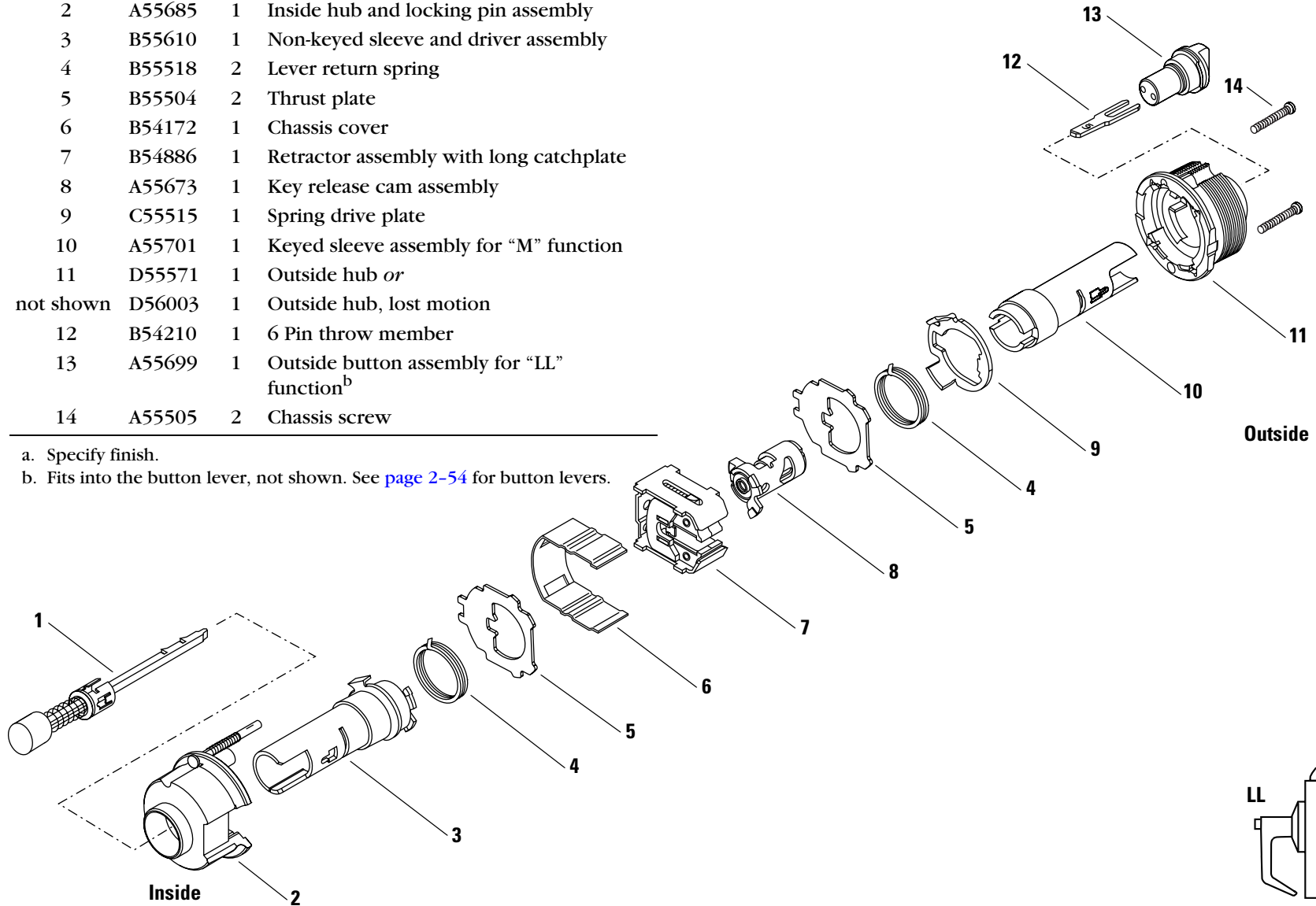
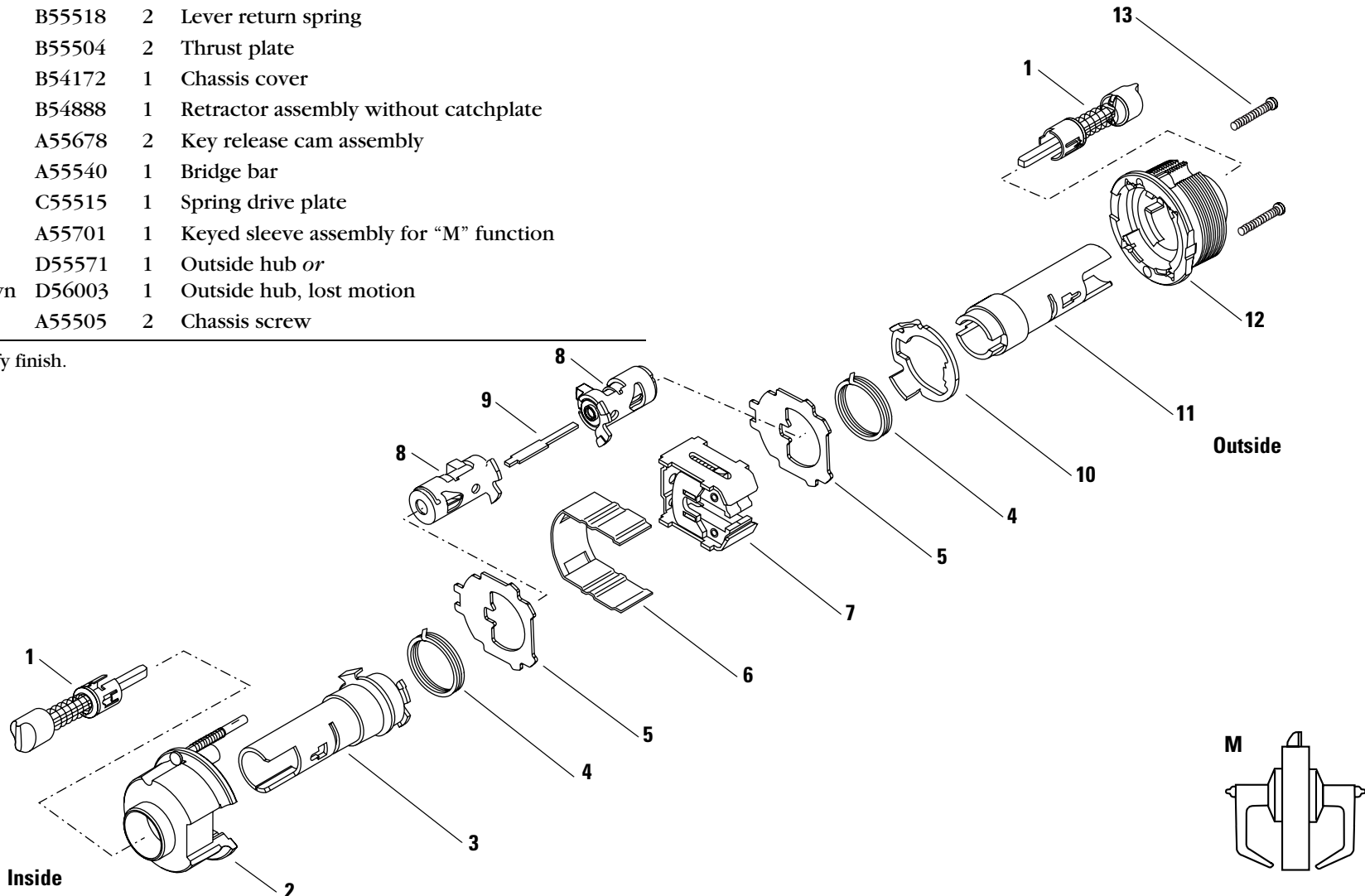

Figure 2.23 LL function exploded diagram

# M FUNCTION CHASSIS—COMMUNICATING LOCK (ANSI F78)

Item	Part No.	Qty.	Description
1	A55695	2	Turn button assembly <sup>a</sup>
2	A55685	1	Inside hub and locking pin assembly
not shown	A56008	1	Inside hub and locking pin assembly, lost motion
3	B55610	1	Non-keyed sleeve and driver assembly
4	B55518	2	Lever return spring
5	B55504	2	Thrust plate
6	B54172	1	Chassis cover
7	B54888	1	Retractor assembly without catchplate
8	A55678	2	Key release cam assembly
9	A55540	1	Bridge bar
10	C55515	1	Spring drive plate
11	A55701	1	Keyed sleeve assembly for "M" function
12	D55571	1	Outside hub <i>or</i>
not shown	D56003	1	Outside hub, lost motion
13	A55505	2	Chassis screw

a. Specify finish.

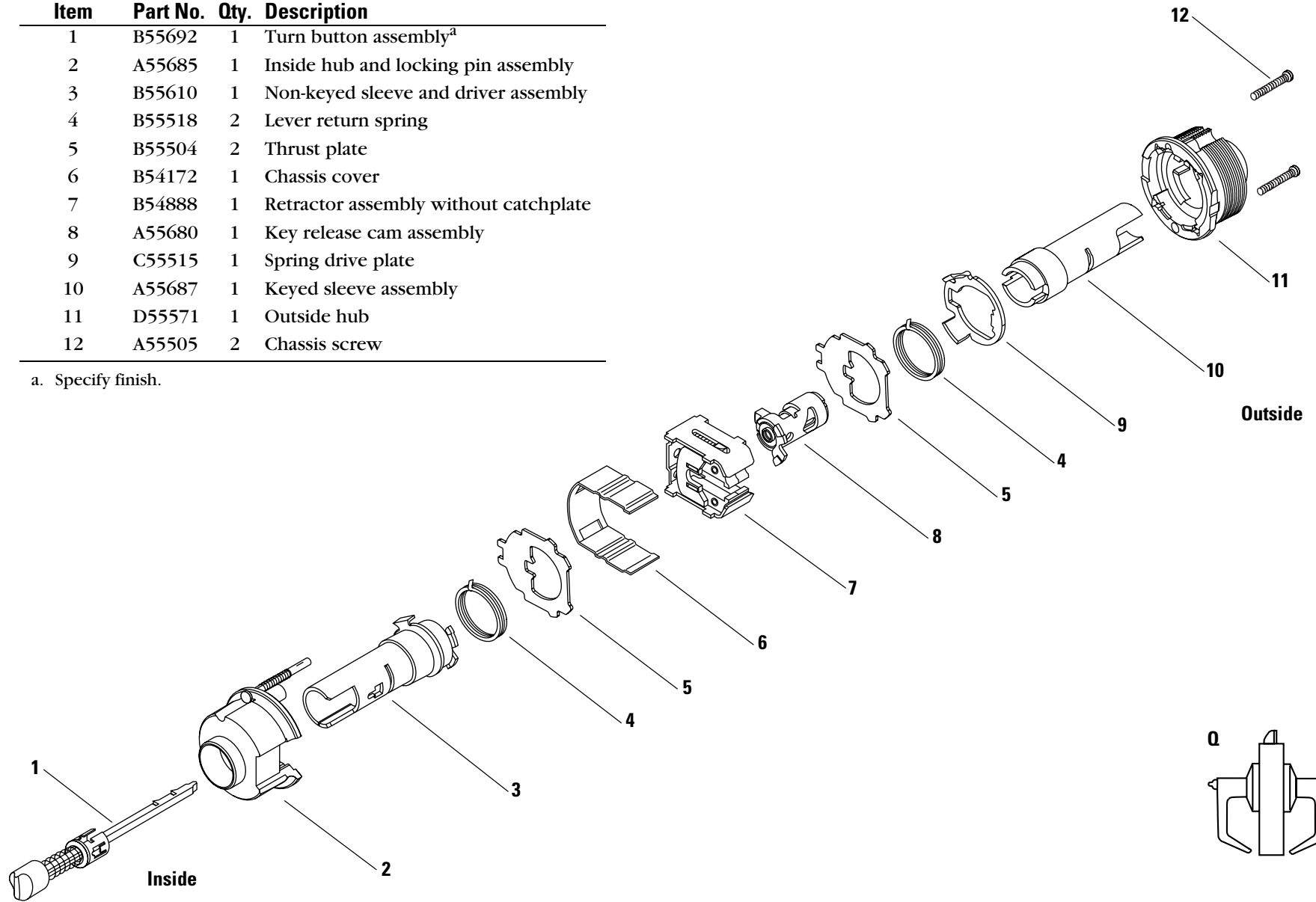

**Figure 2.24** M function exploded diagram

## Q FUNCTION CHASSIS—EXIT LOCK (ANSI F83)

Item	Part No.	Qty.	Description
1	B55692	1	Turn button assembly <sup>a</sup>
2	A55685	1	Inside hub and locking pin assembly
3	B55610	1	Non-keyed sleeve and driver assembly
4	B55518	2	Lever return spring
5	B55504	2	Thrust plate
6	B54172	1	Chassis cover
7	B54888	1	Retractor assembly without catchplate
8	A55680	1	Key release cam assembly
9	C55515	1	Spring drive plate
10	A55687	1	Keyed sleeve assembly
11	D55571	1	Outside hub
12	A55505	2	Chassis screw

a. Specify finish.



**Figure 2.25** Q function exploded diagram

# RD FUNCTION CHASSIS—SPECIAL LOCK

Item	Part No.	Qty.	Description
1	A55685	1	Inside hub and locking pin assembly <i>or</i>
not shown	A56008	1	Inside hub assembly, lost motion
2	A55687	2	Keyed sleeve assembly <i>or</i>
not shown	A55725	2	Keyed sleeve assembly <sup>a</sup>
3	C55515	2	Spring drive plate
4	B55504	2	Thrust plate
5	A55675	1	Key release cam assembly
6	B54172	1	Chassis cover
7	B54888	1	Retractor assembly without catchplate
8	B55681	1	Key release cam assembly
9	B55518	1	Lever return spring
10	D55571	1	Outside hub <i>or</i>
not shown	D56003	1	Outside hub, lost motion
11	A55505	2	Chassis screw

a. For use with non-interchangeable cores.

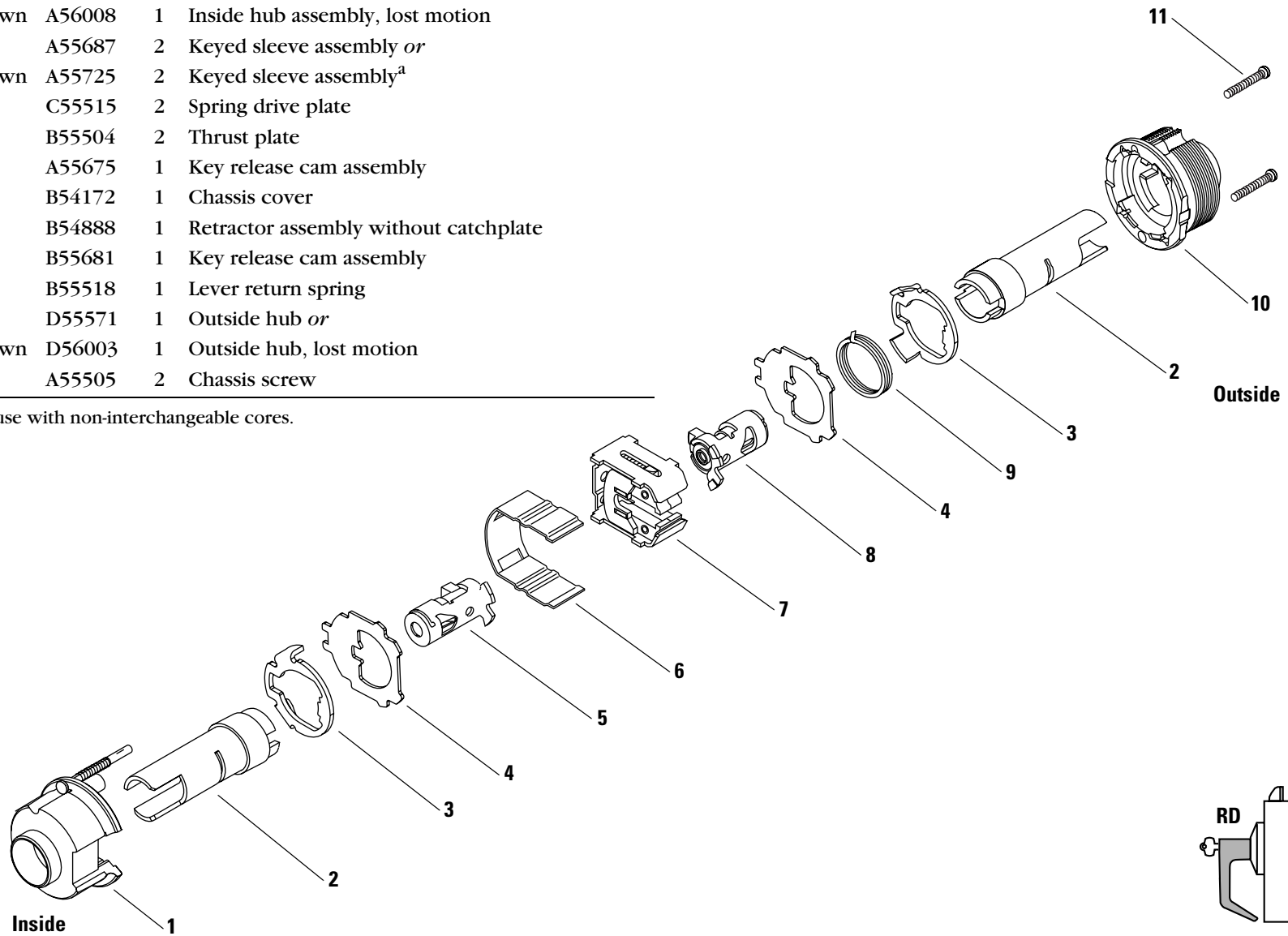

Figure 2.26 RD function exploded diagram



## RZ FUNCTION CHASSIS—CLOSET OR STOREROOM LOCK

Item	Part No.	Qty.	Description
1	A54736	1	Turn blade assembly for Z function <sup>a</sup>
2	A54810	1	Inside hub and side plate assembly
3	A54835	1	Non-keyed sleeve and driver assembly
4	B54172	1	Chassis cover
5	B54888	1	Retractor assembly without catchplate
6	B55681	1	Key release cam assembly
7	B55504	1	Thrust plate
8	B55518	1	Lever return spring
9	C55515	1	Spring drive plate
10	A55687	1	Keyed sleeve assembly <i>or</i>
not shown	A55725	1	Keyed sleeve assembly <sup>b</sup>
11	D55571	1	Outside hub <i>or</i>
not shown	D56003	1	Outside hub, lost motion
12	A55511	2	Chassis screw

a. Specify finish.

b. For use with non-interchangeable cores.

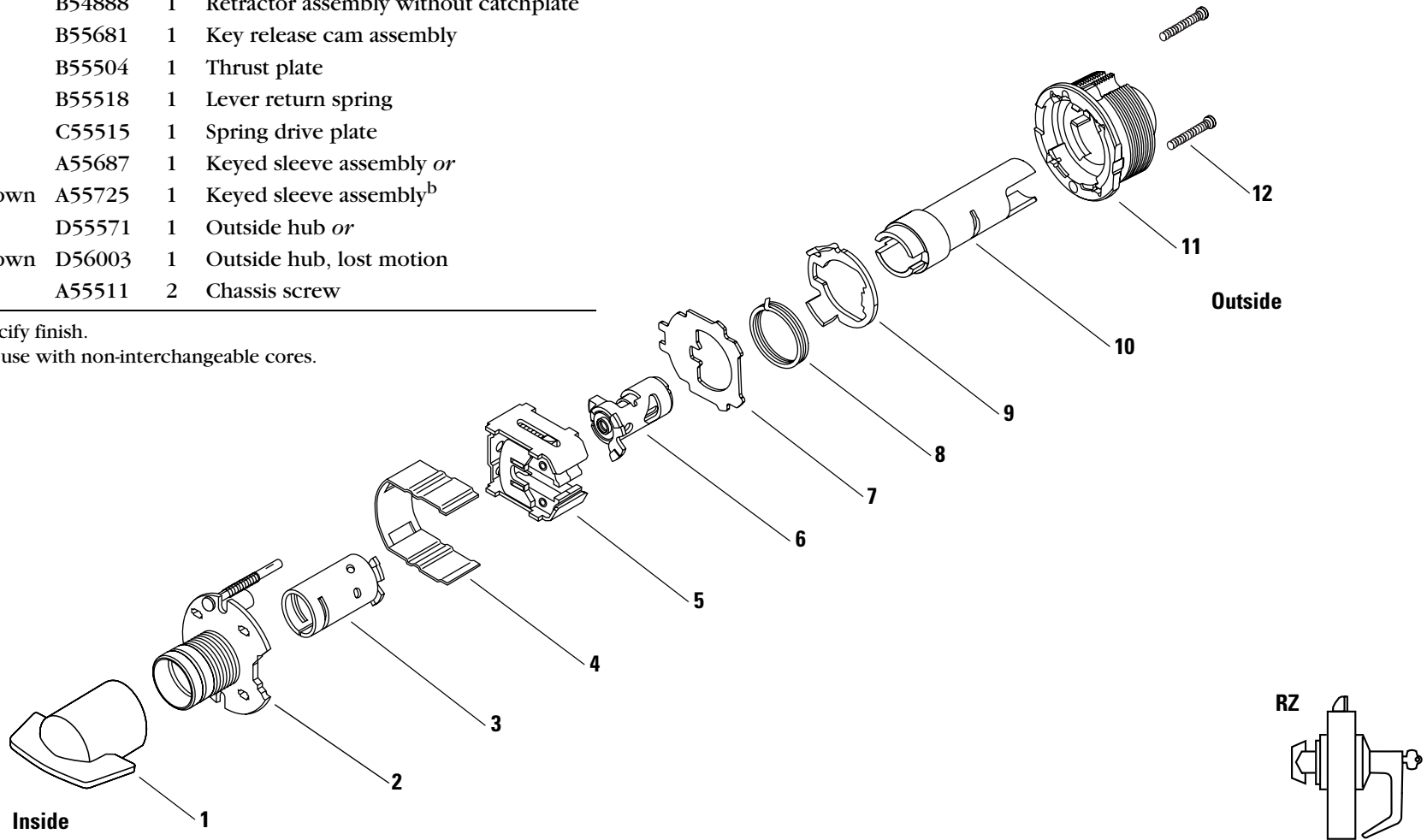

**Figure 2.27** RZ function exploded diagram

# XD FUNCTION CHASSIS—SPECIAL LOCK

Item	Part No.	Qty.	Description
1	A55685	1	Inside hub and locking pin assembly <i>or</i>
not shown	A56008	1	Inside hub assembly, lost motion
2	A55687	2	Keyed sleeve assembly <i>or</i>
not shown	A55725	1	Keyed sleeve assembly <sup>a</sup>
3	C55515	2	Spring drive plate
4	B55504	2	Thrust plate
5	A55675	1	Key release cam assembly
6	B54172	1	Chassis cover
7	B54888	1	Retractor assembly without catchplate
8	B55682	1	Key release cam assembly
9	D55571	1	Outside hub <i>or</i>
not shown	D56003	1	Outside hub, lost motion
10	A55505	2	Chassis screw

a. For use with non-interchangeable cores.

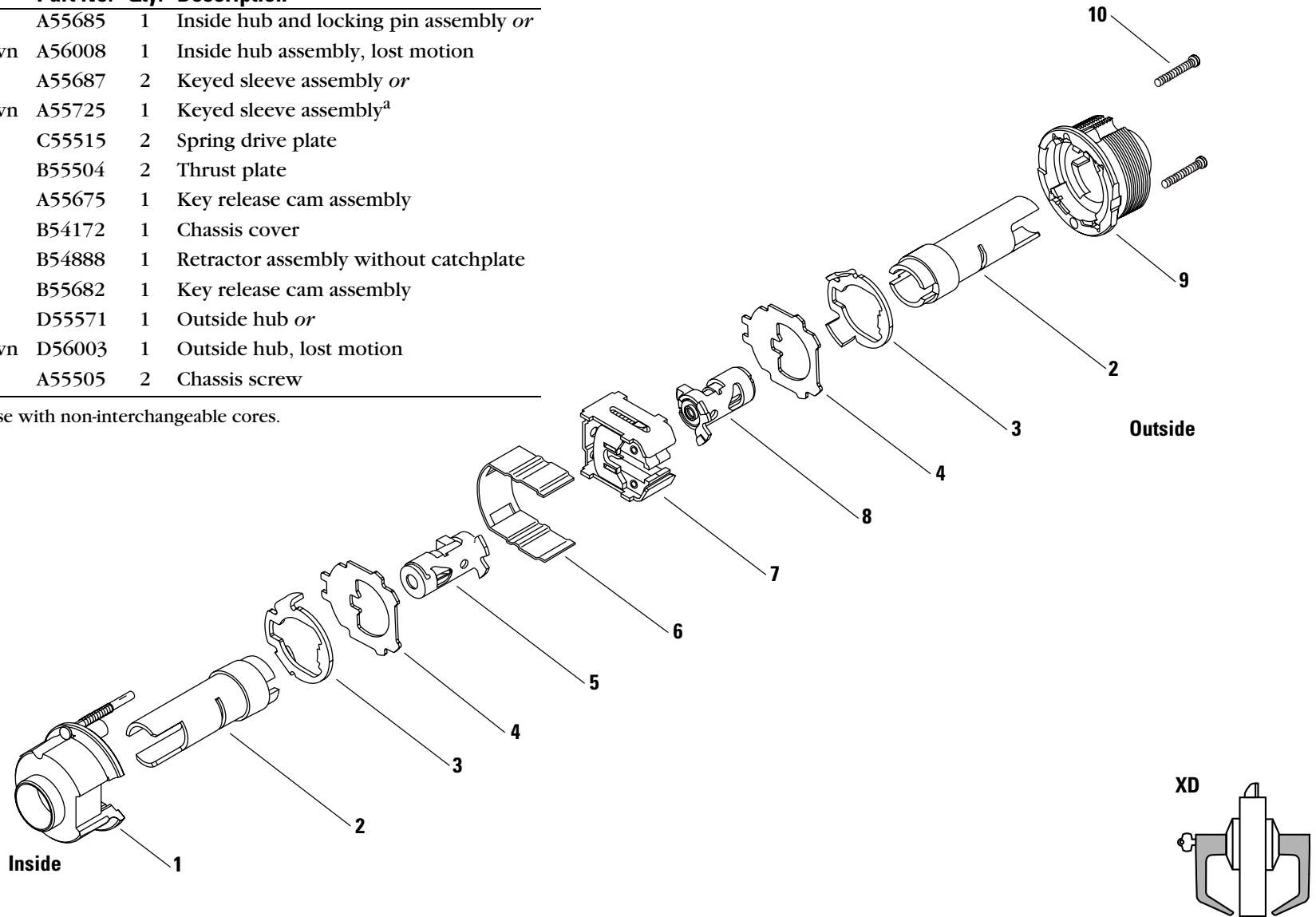

Figure 2.28 XD function exploded diagram

# XR FUNCTION CHASSIS—SPECIAL LOCK

Item	Part No.	Qty.	Description
1	A55685	1	Inside hub and locking pin assembly <i>or</i>
not shown	A56008	1	Inside hub assembly, lost motion
2	A55687	2	Keyed sleeve assembly <i>or</i>
not shown	A55725	2	Keyed sleeve assembly <sup>a</sup>
3	C55515	2	Spring drive plate
4	B55518	1	Lever return spring
5	B55504	2	Thrust plate
6	A55681	1	Key release cam assembly
7	B54172	1	Chassis cover
8	B54888	1	Retractor assembly without catchplate
9	B55682	1	Key release cam assembly
10	D55571	1	Outside hub <i>or</i>
not shown	D56003	1	Outside hub, lost motion
11	A55505	2	Chassis screw

a. For use with non-interchangeable cores.

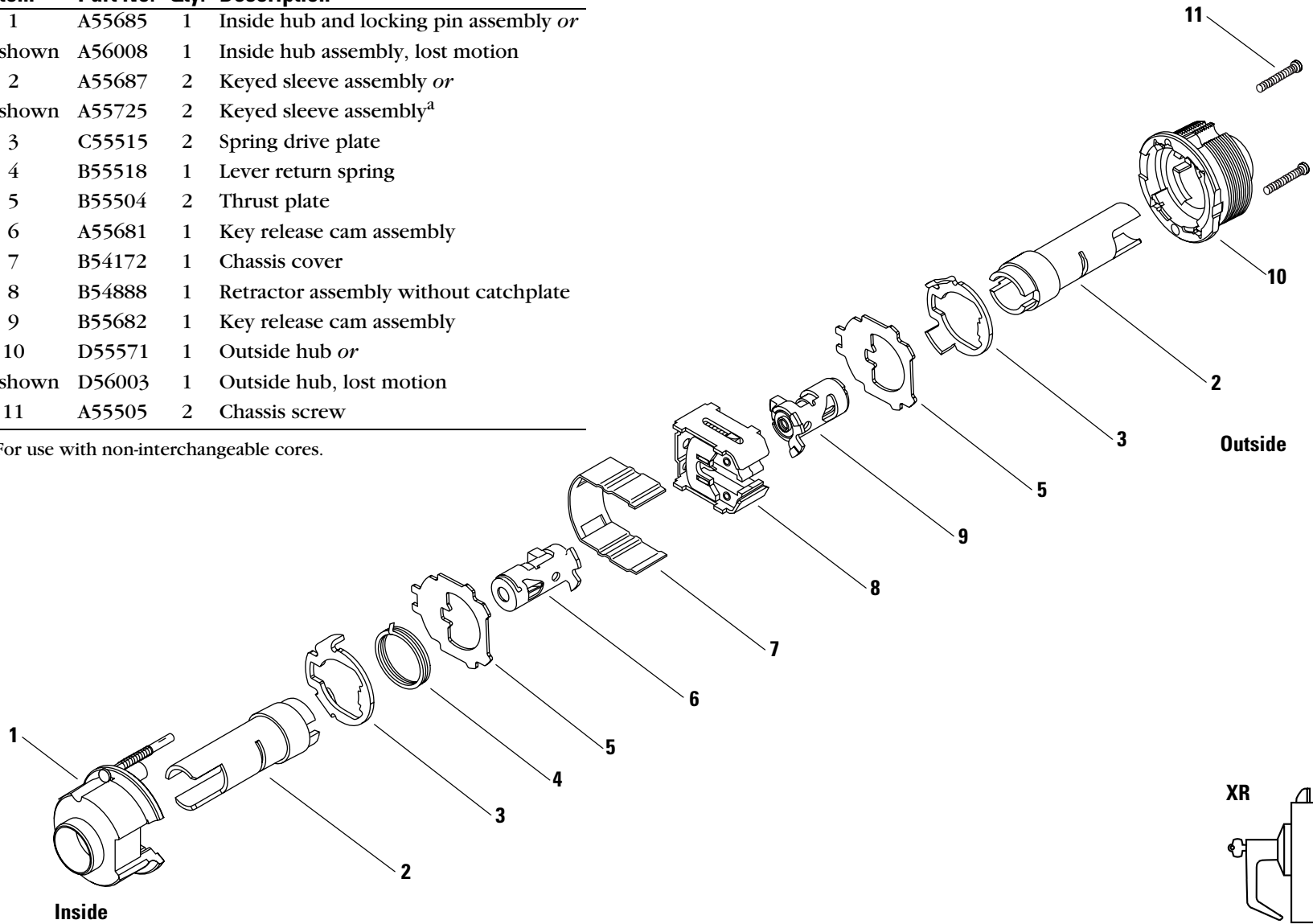
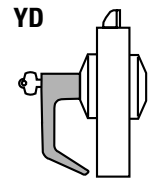
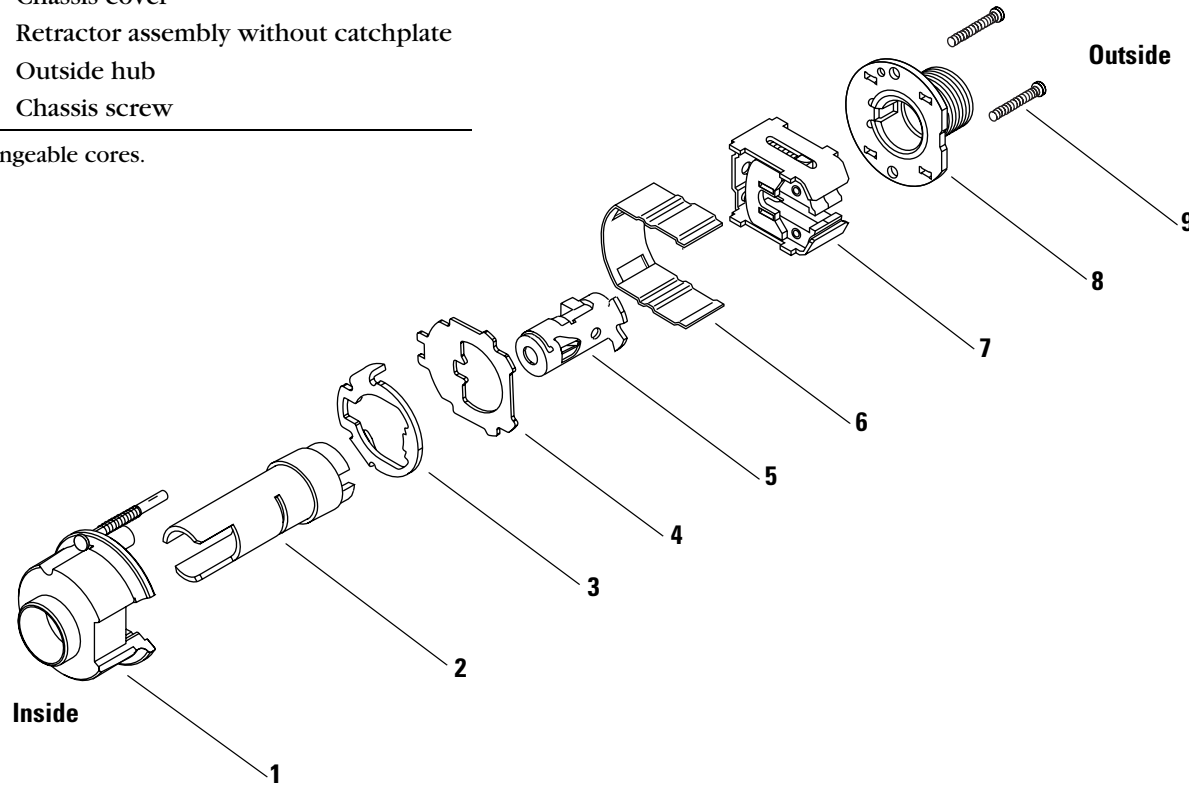

Figure 2.29 XR function exploded diagram

# YD FUNCTION CHASSIS—EXIT LOCK

Item	Part No.	Qty.	Description
1	A55685	1	Inside hub and locking pin assembly <i>or</i>
not shown	A56008	1	Inside hub assembly, lost motion
2	A55687	1	Keyed sleeve assembly <i>or</i>
not shown	A55725	1	Keyed sleeve assembly <sup>a</sup>
3	C55515	1	Spring drive plate
4	B55504	1	Thrust plate
5	A55675	1	Key release cam assembly
6	B54172	1	Chassis cover
7	B54888	1	Retractor assembly without catchplate
8	B54809	1	Outside hub
9	A55511	2	Chassis screw

a. For use with non-interchangeable cores.

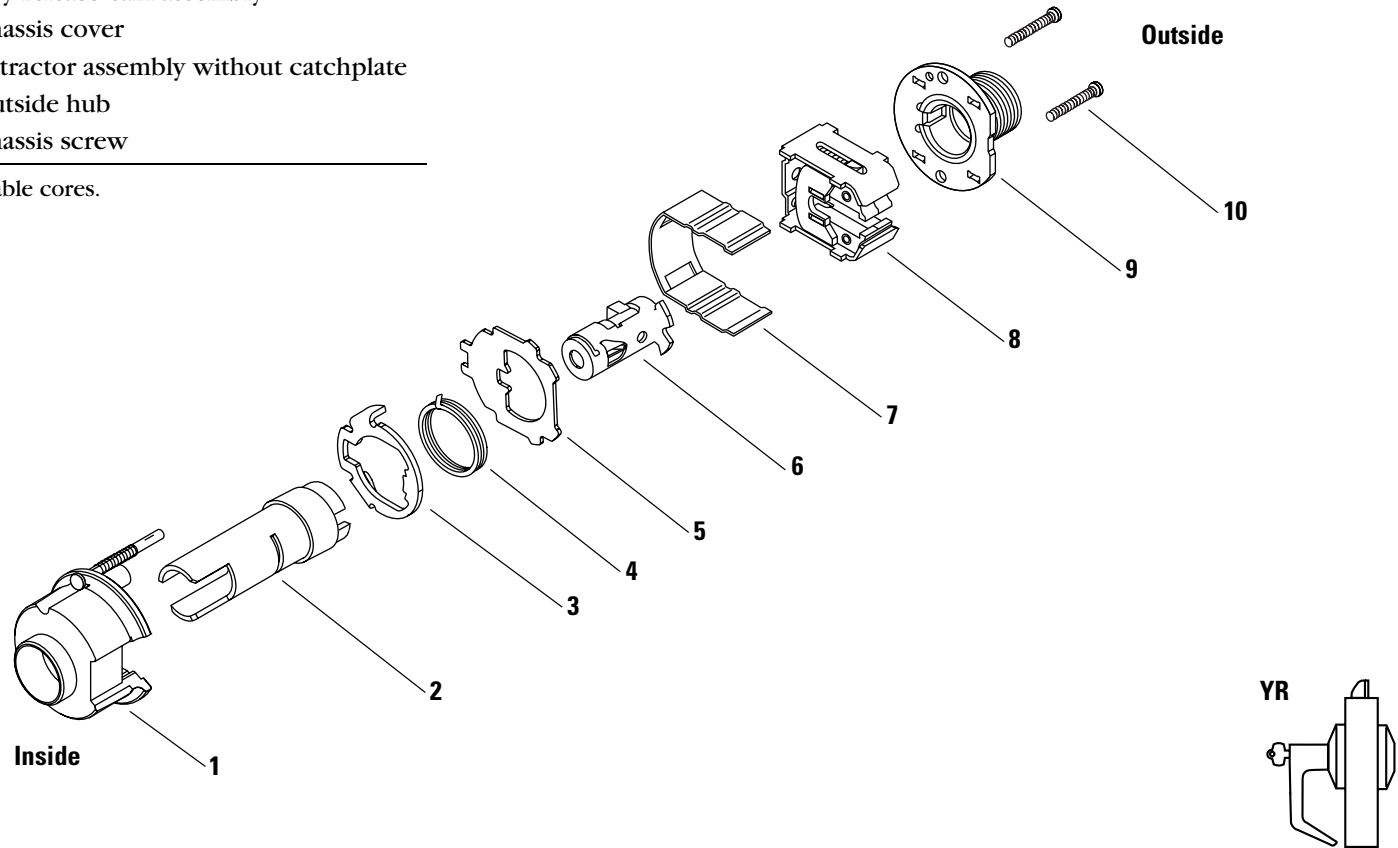

**Figure 2.30** YD function exploded diagram

## YR FUNCTION CHASSIS—SPECIAL LOCK

Item	Part No.	Qty.	Description
1	A55685	1	Inside hub and locking pin assembly <i>or</i>
not shown	A56008	1	Inside hub assembly, lost motion
2	A55687	1	Keyed sleeve assembly <i>or</i>
not shown	A55725	1	Keyed sleeve assembly <sup>a</sup>
3	C55515	1	Spring drive plate
4	B55518	1	Lever return spring
5	B55504	1	Thrust plate
6	A55681	1	Key release cam assembly
7	B54172	1	Chassis cover
8	B54888	1	Retractor assembly without catchplate
9	B54809	1	Outside hub
10	A55511	2	Chassis screw

a. For use with non-interchangeable cores.

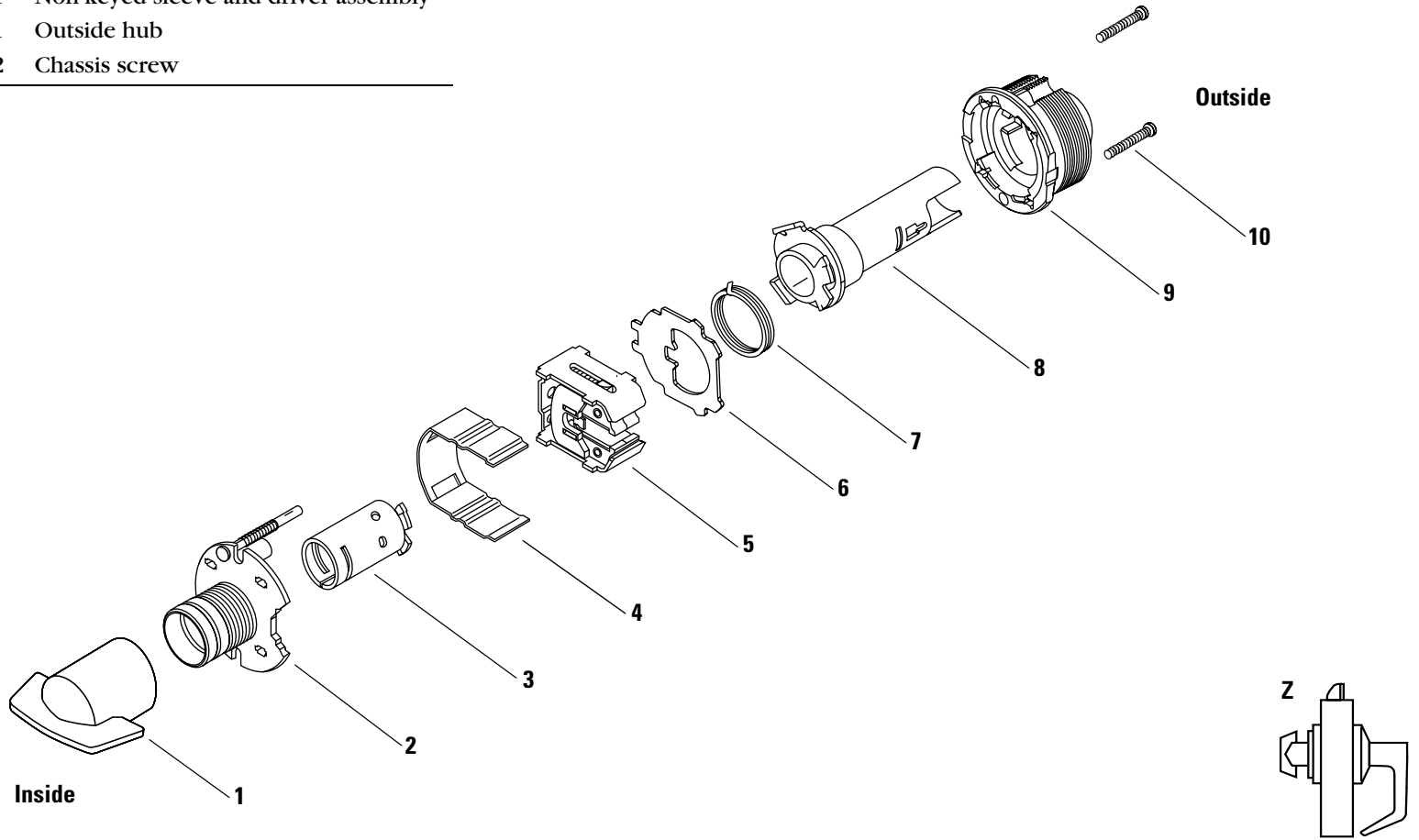

**Figure 2.31** YR function exploded diagram

# Z FUNCTION CHASSIS—CLOSET LOCK

Item	Part No.	Qty.	Description
1	A54736	1	Turn blade assembly for Z function <sup>a</sup>
2	A54810	1	Inside hub and side plate assembly
3	A54835	1	Non-keyed sleeve and driver assembly
4	B54172	1	Chassis cover
5	B54888	1	Retractor assembly without catchplate
6	B55504	1	Thrust plate
7	B55518	1	Lever return spring
8	A55610	1	Non-keyed sleeve and driver assembly
9	D55571	1	Outside hub
10	A55511	2	Chassis screw

a. Specify finish.



**Figure 2.32** Z function exploded diagram

# ELECTRIFIED FUNCTIONS DEL FUNCTION CHASSIS—ELECTRICALLY LOCKED FAIL SAFE

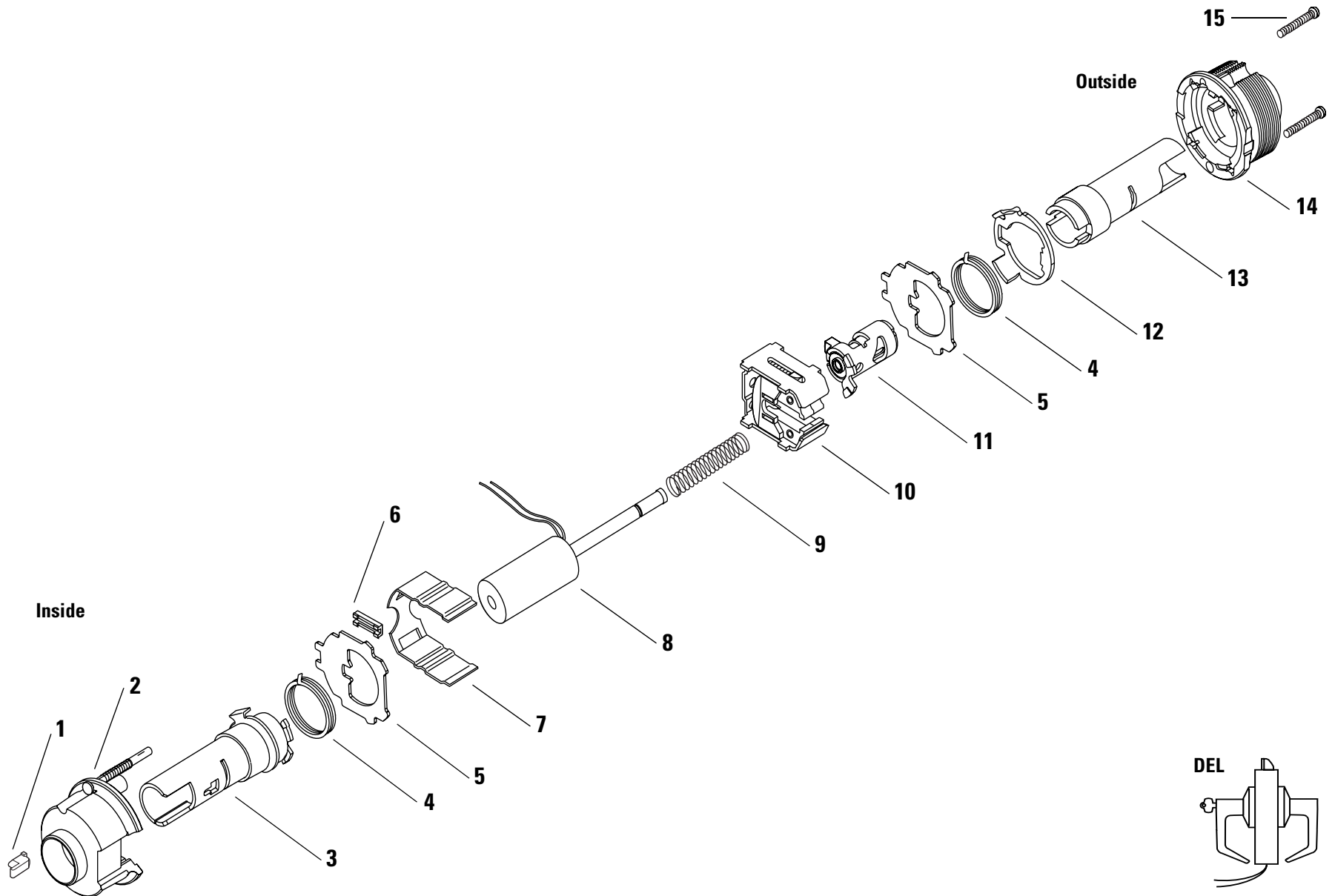

Figure 2.33 DEL function exploded diagram

**DEL function parts list**

Refer to [Figure 2.33](#) and the table below to find the part you need or to convert the function of the lock.

Item	Part no.	Qty.	Description
1	B60207	1	Switch plunger
2	A55685	1	Inside hub assembly <i>or</i>
not shown	C60206	1	Inside hub assembly for RQE
3	B60217	1	Modified drive collar & non-keyed sleeve assembly <i>or</i>
4	B55518	2	Lever return spring
5	B55504	2	Thrust plate
6	B60470	1	Wire protector cap
7	B54172	1	Chassis cover
not shown	A60227	1	ID label (affixed to the chassis cover)
8	C60232	1	Solenoid
9	A60224	1	Solenoid spring
10	B60463	1	Chassis frame and retractor assembly
11	A60541	1	Key release cam assembly
12	C55515	1	Spring drive plate
13	A55687	1	Keyed sleeve assembly <i>or</i>
not shown	A55725	1	Keyed sleeve assembly <sup>a</sup>
14	D55571	1	Outside hub <i>or</i>
not shown	D56003	1	Outside hub, lost motion
15	A55505	2	Chassis screw

a. For use with non-interchangeable cores.



# DEU FUNCTION CHASSIS—ELECTRICALLY UNLOCKED FAIL SAFE

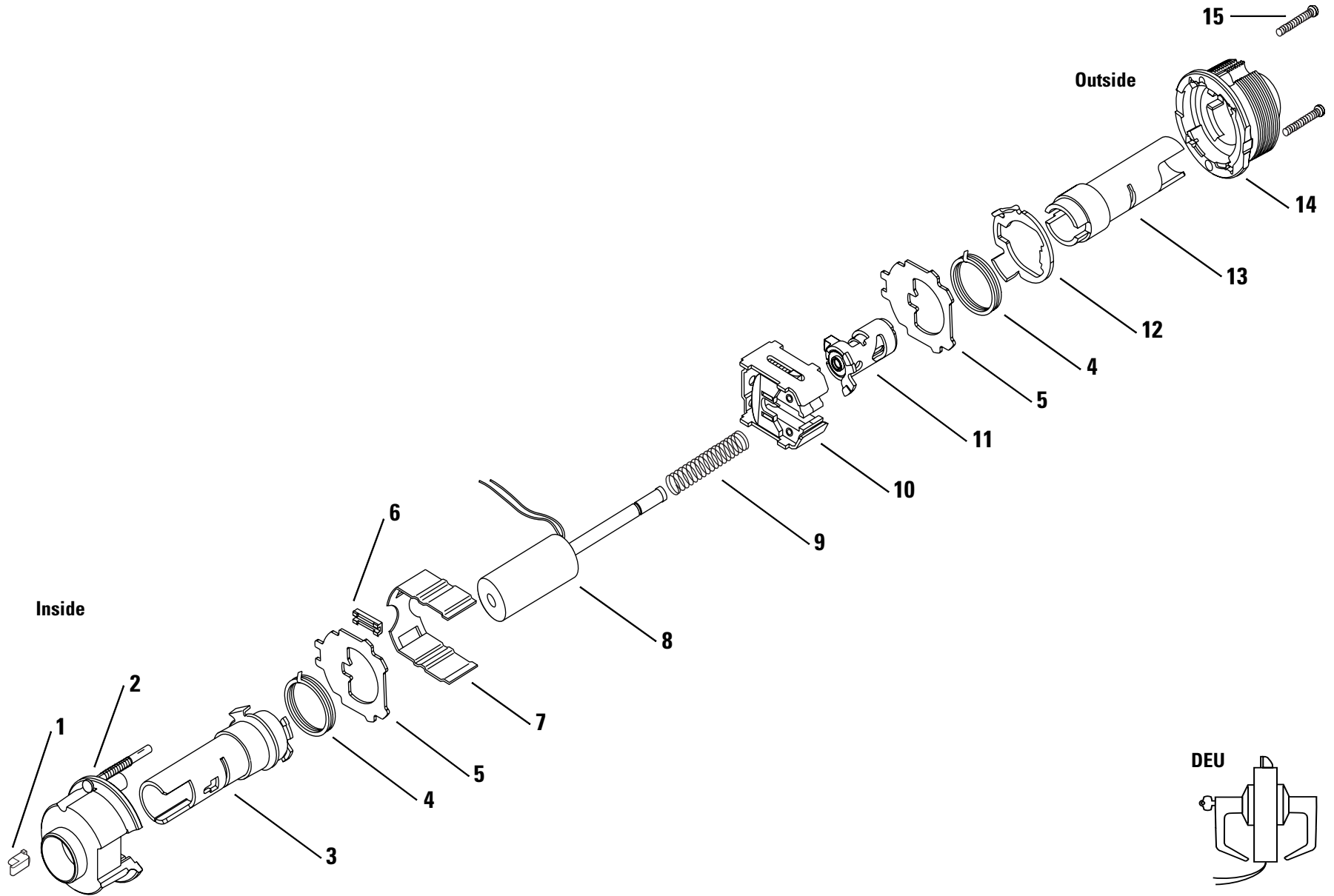

**Figure 2.34** DEU function exploded diagram

**DEU function parts list**

Refer to [Figure 2.34](#) and the table below to find the part you need or to convert the function of the lock.

Item	Part no.	Qty.	Description
1	B60207	1	Switch plunger
2	A55685	1	Inside hub assembly <i>or</i>
not shown	C60206	1	Inside hub assembly for RQE
3	B60217	1	Modified drive collar & non-keyed sleeve assembly
4	B55518	2	Lever return spring
5	B55504	2	Thrust plate
6	B60470	1	Wire protector cap
7	B54172	1	Chassis cover
not shown	A60227	1	ID label (affixed to the chassis cover)
8	C60231	1	Solenoid
9	A60223	1	Solenoid spring
10	B60463	1	Chassis frame and retractor assembly
11	A60531	1	Key release cam assembly
12	C55515	1	Spring drive plate
13	A55687	1	Keyed sleeve assembly <i>or</i>
not shown	A55725	1	Keyed sleeve assembly <sup>a</sup>
14	D55571	1	Outside hub <i>or</i>
not shown	D56003	1	Outside hub, lost motion
15	A55505	2	Chassis screw

a. For use with non-interchangeable cores.

## FUNCTION CONVERSION

If you want to convert the function of an existing 9K Lock, use the following tables to determine the internal parts that you need. Unless otherwise noted, a quantity of one is used for each part.

Standard functions

Part No.	Description	AB	C	D	E	G	H/HJ	L	N	NX	P	R	S	T	W	Y
A54745	Button release assembly							■								
B55690	Locking bar assembly for “NX” function									■						
B55692	Turn button assembly	■														
B55693	Push button assembly						■	■			■			■		
B55694	Slotted button assembly				■											
A55685	Inside hub and locking pin assembly	■	■	■	■	■	■	■	■	■	■	■	■	■	■	■
A56008	Inside hub assembly, lost motion <sup>a</sup>		■			■							■		■	
B54809	Outside hub & plate assembly															■
D55571	Outside hub	■	■	■	■	■	■	■	■	■	■	■	■	■	■	■
D56003	Outside hub, lost motion <sup>b</sup>	■	■	■	■	■	■	■		■	■	■	■	■	■	■
B55610	Non-keyed sleeve and driver assembly	■		■	■		■	■	■	■	■	■		■		■
A55687	Keyed sleeve assembly	■	■	■	■	■ <sup>c</sup>	■		■	■	■	■	■ <sup>c</sup>	■	■ <sup>c</sup>	
B55700	Sleeve & key release cam assembly		■													
A55701	Keyed sleeve assembly for “M” function							■								
A55725	Non-IC keyed sleeve assembly <sup>d</sup>	■	■	■	■	■ <sup>c</sup>						■	■ <sup>c</sup>	■	■ <sup>c</sup>	
B56024	Non-IC sleeve & key release cam assembly <sup>e</sup>		■													
B54172	Chassis cover	■	■	■	■	■	■	■	■	■	■	■	■	■	■	■
B55504	Thrust plate (quantity 2)	■	■	■	■	■	■	■	■	■	■	■	■	■	■	■ <sup>f</sup>
C55515	Spring drive plate	■	■ <sup>c</sup>	■	■	■ <sup>c</sup>	■	■		■	■	■	■ <sup>c</sup>	■	■ <sup>c</sup>	
B55518	Lever return spring (quantity 2)	■	■	■ <sup>f</sup>	■	■	■ <sup>f</sup>	■	■	■ <sup>f</sup>	■	■	■	■	■	■ <sup>f</sup>
B54886	Retractor assembly with long catchplate	■			■		■	■			■			■		
B54888	Retractor assembly without catchplate		■	■		■			■	■		■	■		■	■
A55673	Key release cam assembly	■	■		■			■								
A55675	Key release cam assembly			■											■ <sup>c</sup>	
A55676	Key release cam assembly					■ <sup>c</sup>										
A55677	Key release cam assembly						■									
A55680	Key release cam assembly									■	■					
A55681	Key release cam assembly											■	■ <sup>c</sup>	■		
A54190	Locking bar		■													
A54195	Locking bar					■										
A55505	Chassis screw (quantity 2)	■	■	■	■	■	■	■	■	■	■	■	■	■	■	■
A55511	Chassis screw (quantity 2)															■

- a. For the lost motion function, use in place of the inside hub assembly, A55685.
- b. For the lost motion function, use in place of the outside hub, D55571.
- c. Use a quantity of two (2).
- d. For the non-IC function, use in place of the keyed sleeve assembly, A55687.
- e. For the non-IC function, use in place of the sleeve & key release cam assembly, B55700.
- f. Use a quantity of one (1).

**Non-standard functions**

Part No.	Description	A	B	DR	DZ	EA	IN	LL	M	O	RD	RZ	XD	XR	YD	YR	Z
A54736	Turn blade assembly for “Z” function				■							■					■
B55692	Turn button assembly	■								■							
B55693	Push button assembly		■					■									
B55694	Slotted button assembly					■											
A55695	Turn button assembly (quantity 2)								■								
A55699	Outside button assembly for “LL” function <sup>a</sup>							■									
B54810	Inside hub and side plate assembly				■							■					■
A55685	Inside hub and locking pin assembly	■	■	■		■	■	■	■	■	■		■	■	■	■	■
A56008	Inside hub assembly, lost motion <sup>b</sup>			■			■		■		■		■	■	■	■	
B54809	Outside hub & plate assembly														■	■	
D55571	Outside hub	■	■	■	■	■		■	■	■	■	■	■	■			■
D56003	Outside hub, lost motion <sup>c</sup>	■	■		■	■	■	■	■		■	■	■	■			
A54835	Non-keyed sleeve and driver assembly				■							■					■
B55610	Non-keyed sleeve and driver assembly	■	■			■		■	■	■							■
A55687	Keyed sleeve assembly	■	■	■ <sup>d</sup>	■	■	■ <sup>d</sup>			■	■ <sup>d</sup>	■	■ <sup>d</sup>	■ <sup>d</sup>	■	■	■
A55701	Keyed sleeve assembly for “M” function							■	■								
A55725	Keyed sleeve assembly <sup>e</sup>	■	■	■ <sup>d</sup>	■	■	■ <sup>d</sup>				■ <sup>d</sup>	■	■	■	■	■	■
B54172	Chassis cover	■	■	■	■	■	■	■	■	■	■	■	■	■	■	■	■
A54195	Locking bar						■										
B55504	Thrust plate (quantity 2)	■	■	■	■ <sup>f</sup>	■	■	■	■	■	■	■ <sup>f</sup>	■	■	■ <sup>f</sup>	■ <sup>f</sup>	■ <sup>f</sup>
C55515	Spring drive plate	■	■	■ <sup>d</sup>	■	■	■ <sup>d</sup>	■	■	■	■ <sup>d</sup>	■	■ <sup>d</sup>	■ <sup>d</sup>	■	■	■
B55518	Lever return spring (quantity 2)	■	■	■ <sup>f</sup>		■	■	■	■	■	■ <sup>f</sup>	■ <sup>f</sup>		■ <sup>f</sup>		■ <sup>f</sup>	■ <sup>f</sup>
A55540	Bridge bar								■								
B54886	Retractor assembly with long catchplate							■									
B54887	Retractor assembly with short catchplate		■			■											
B54888	Retractor assembly without catchplate	■		■	■		■		■	■	■	■	■	■	■	■	■
A55673	Key release cam assembly	■	■			■		■									
A55675	Key release cam assembly			■	■						■		■		■		
A55676	Key release cam assembly						■										
A55678	Key release cam assembly (quantity 2)								■								
A55680	Key release cam assembly									■							
A55681	Key release cam assembly			■							■	■		■		■	
A55682	Key release cam assembly												■	■			
A56038	Key release cam assembly						■										
A55505	Chassis screw (quantity 2)	■	■	■		■	■	■	■	■	■		■	■			
A55511	Chassis screw (quantity 2)				■							■			■	■	■

- a. One (1) six pin throw member, B54210, is also required.
- b. For the lost motion function, use in place of the inside hub assembly B55056 or A55685.
- c. For the lost motion function, use in place of the outside hub, D55571.
- d. Use a quantity of two (2).
- e. For the non-interchangeable function, use in place of the keyed sleeve and driver assembly, A55687.
- f. Use a quantity of one (1).

## TRIM PARTS

### Standard strikes and strike boxes

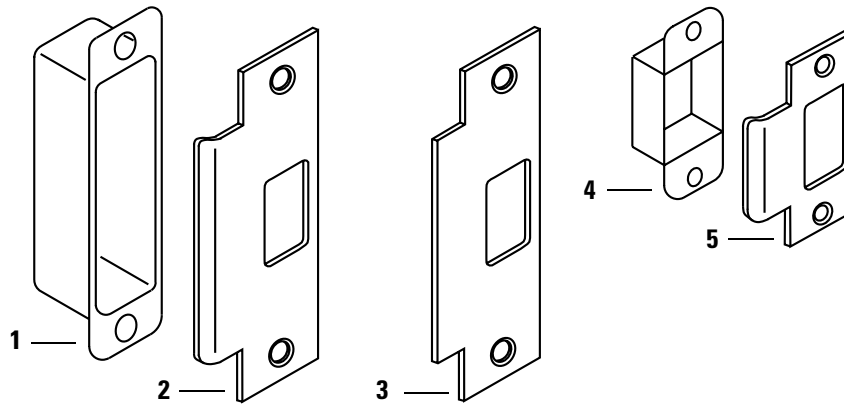

**Figure 2.35** Standard strikes and strike boxes

### Standard strikes and strike boxes parts list

Item	Nomenclature	Part no.	Description
1	30HS4	B34380	ANSI plastic strike box
2	8KS3 <sup>a</sup>	B25641	ANSI strike plate
3	83KS3	C63016	ANSI 7/8" flat lip strike
4	8KS1	B25640	Standard steel strike box
5	8KS2 <sup>b</sup>	B25639	Standard strike plate

- a. Two (2) A25359 latch screws and two (2) A18724 strike screws are included with the 8KS3 strike. The 30HS4 ANSI Strike box is not included.
- b. Four (4) A25359 screws are included with the 8KS2 strike—two (2) for the latch and two (2) for the strike.

### Non-standard strikes

### Non-standard strikes parts list

Part no. <sup>a</sup>	X dimension
B54063	7/8"
B54064	1"
B54065	1 1/8"
B54066	1 1/2"
B54067	1 3/4"
B54068	2"
B54069	2 1/4"
B54070	2 1/2"
B54071	3"
B54072	4"

a. Specify finish.

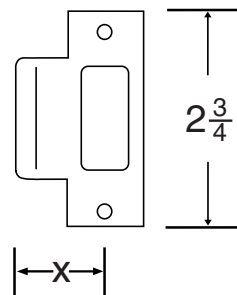

The measurement is taken from the edge of the lip to the center of the screw holes.

**Figure 2.36** Understanding strike lip measurement

**Lead-lined parts** The lead-lined option is available for new lock orders only. Because individual lead-lined parts are not field-serviceable, they are not available to order for replacement parts. In the following graphic, the shaded portions indicate the lead shields.

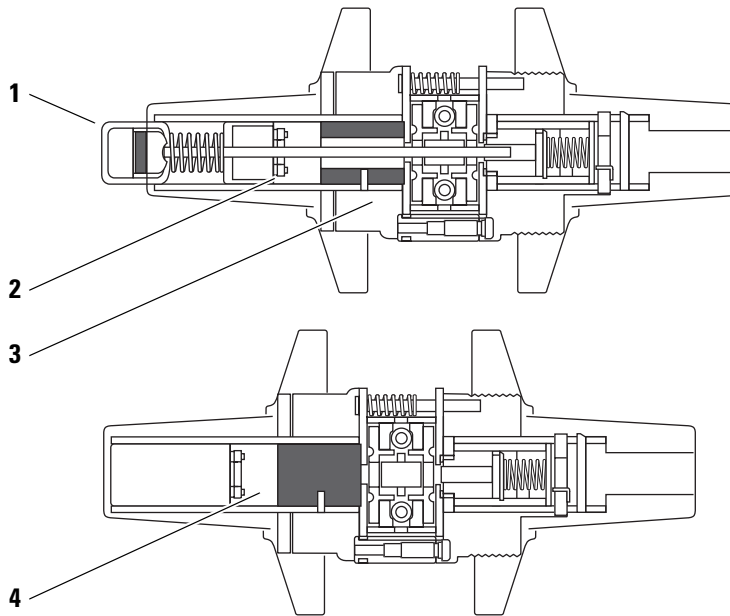

**Figure 2.37** Cross-section of 9K locks showing lead-lined parts

**Lead-lined parts list**

Item	Description
1	Turn button liner with shield
2	Inside lever sleeve with shield (for button levers)
3	Hub and side plate with shield
4	Inside lever sleeve with shield (for plain levers)

Roses, rose liners, and rose spacers

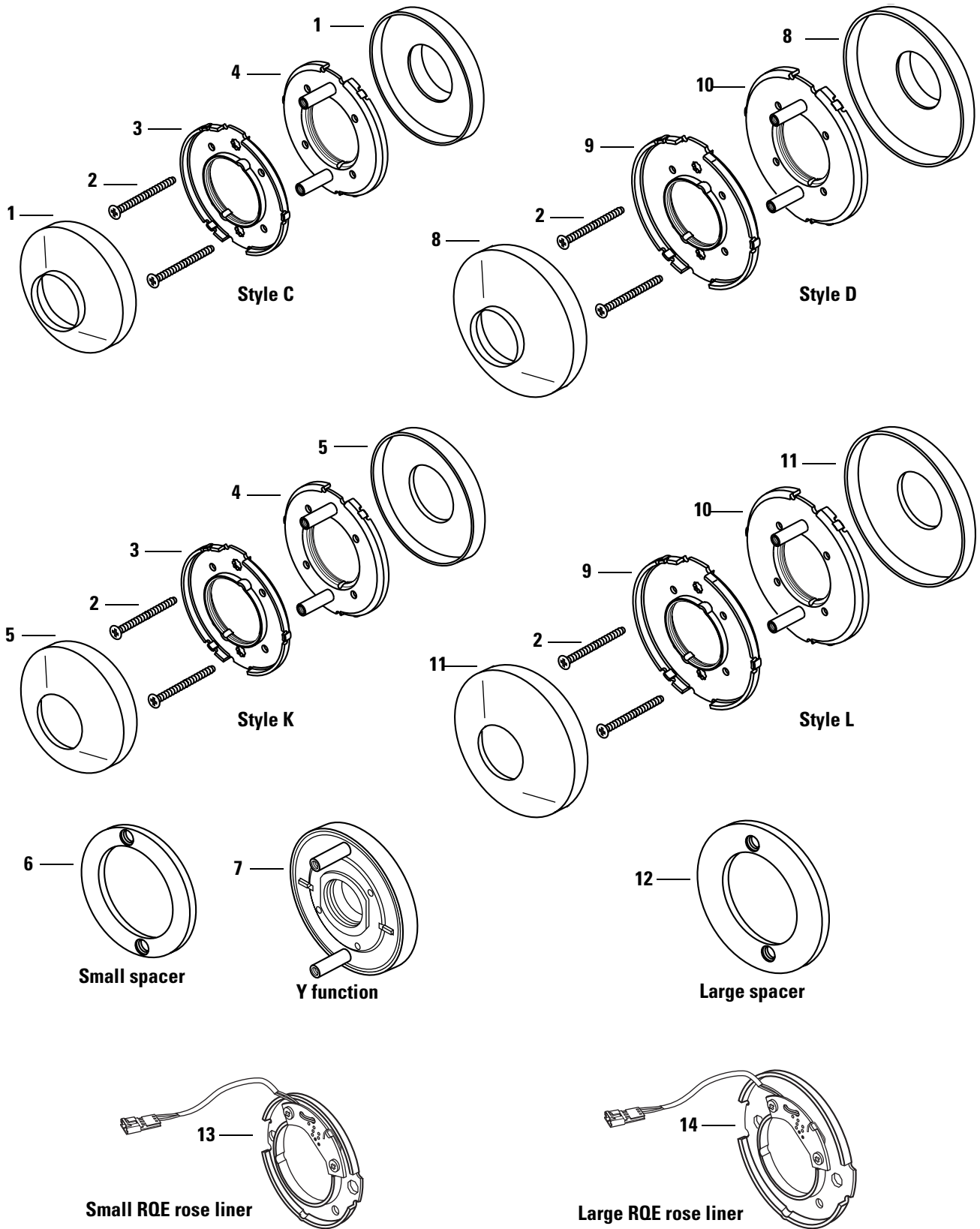

Figure 2.38 Roses, rose liners, and rose spacers



**Roses, rose liners, and rose spacers parts list**

Item	Style	Part no.	Description
1	C	B55015 <sup>a</sup>	Small rose
2	C, D, K, L	A55557	Through-bolt screws
3	C & K	C55556	Small inside rose liner
4	C & K	B55603	Small outside rose liner
5	K	B55018 <sup>a</sup>	Small rose
6	C & K	B55043 <sup>b</sup>	Small rose spacer
7	N/A	A55711	Y function outside rose assembly
8	D	B55007 <sup>a</sup>	Large rose
9	D & L	C55555	Large inside rose liner
10	D & L	B55602	Large outside rose liner
11	L	B55017 <sup>a</sup>	Large rose
12	D & L	B55044 <sup>b</sup>	Large rose spacer
13	N/A	B61049	Small RQE rose liner
14	N/A	B60221	Large RQE rose liner

a. Inside and outside are the same.

b. Two (2) spacers are required for 1 3/8" thick doors.

**Rose and rose liner assemblies parts list**

Item	Style	Part no.	Description
1 & 3	C	B55609	Small inside rose and liner assembly
1 & 4	C	B55605	Small outside rose and liner assembly
3 & 5	K	B55607	Small inside rose and liner assembly
4 & 5	K	B55604	Small outside rose and liner assembly
8 & 9	D	B55608	Large inside rose and liner assembly
8 & 10	D	B55601	Large outside rose and liner assembly
9 & 11	L	B55606	Large inside rose and liner assembly
10 & 11	L	B55600	Large outside rose and liner assembly

**Standard levers and components**

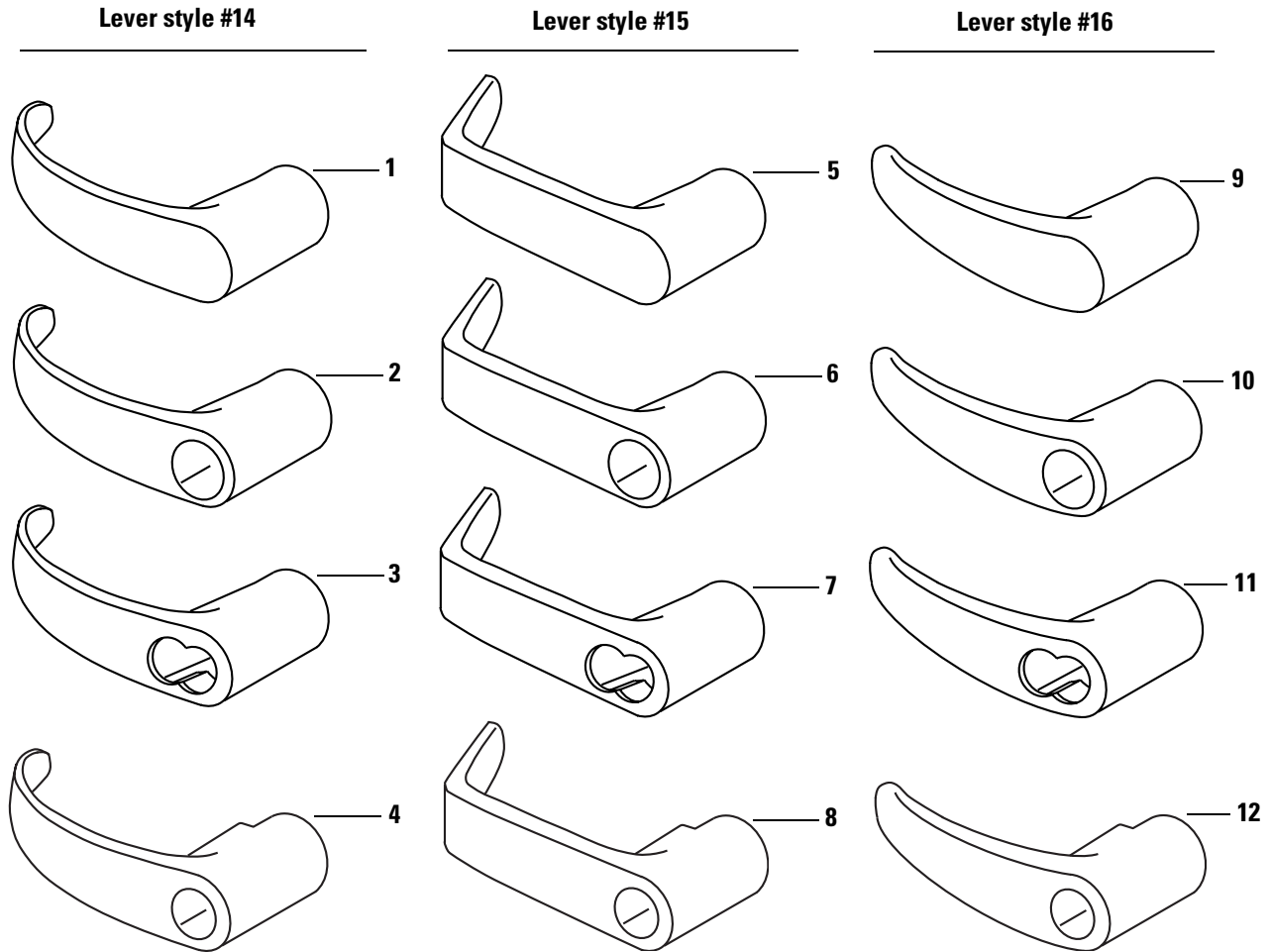

**Figure 2.39** Levers

**Levers parts list**

Style	Item	Part no.	Description
14	1	D55022	Plain lever
	2	D55021	Button lever
	3	D55020	Keyed lever
	not shown	B55100	Keyed lever for H functions
	4	D80989	Universal lever for use with non-interchangeable cores
15	5	B55169	Plain lever
	6	B55170	Button lever
	7	B55168	Keyed lever
	not shown	B55177	Keyed lever for H functions
	8	D55723	Universal lever for use with non-interchangeable cores
16	9	D55025	Plain lever
	10	D55024	Button lever
	11	D55023	Keyed lever
	not shown	B55110	Keyed lever for H functions
	12	D80992	Universal lever for use with non-interchangeable cores

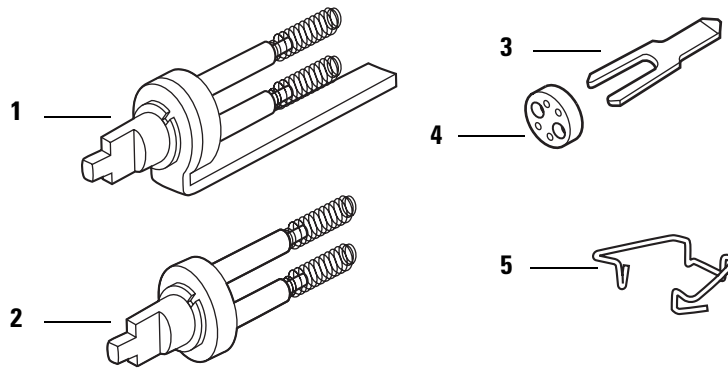

**Figure 2.40** Standard lever components

**Lever components parts list**

Item	Part no.	Qty.	Description
1	A55697	1	“H” throw member
2	A55696	1	“HJ” throw member
3	B54200	1 <sup>a</sup>	Seven pin throw member <sup>b</sup>
4	1882120	50	Six pin spacer
5	B54182	1	Lever keeper spring

a. Single-keyed locks require one (1); double-keyed locks require two (2).

b. For information about cores and keys, see the *Core and Key Service Manual*.

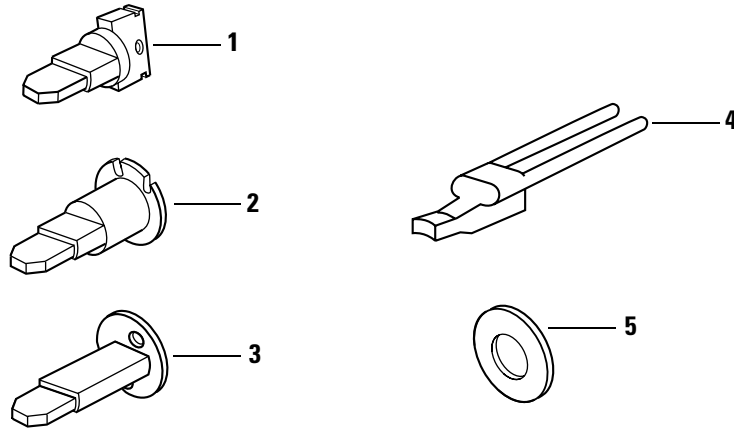

**Figure 2.41** Lever components for use with non-interchangeable cores

**Lever components for use with non-interchangeable cores parts list**

Item	Part no.	Qty.	Description
1	B55709 <sup>a</sup>	1 <sup>b</sup>	Throw member for use with Sargent and Yale cores <sup>c</sup>
2	A55708 <sup>d</sup>	1 <sup>b</sup>	Throw member for use with Schlage, Corbin, KA, KD, and OB cores <sup>c</sup>
3	A55712 <sup>e</sup>	1 <sup>b</sup>	Throw member for use with Medeco core <sup>c</sup>
4	C55714	1 <sup>b</sup>	Lever handle insert for use with non-interchangeable cores
5	A55713	1 <sup>b</sup>	Throw member support ring for use with non-interchangeable cores

- a. To order the kit that contains the throw member, insert, and support ring for use with Sargent cores, use number 1770600. For Yale cores, use number 1770642; this kit contains two throw members, two inserts, and two support rings.
- b. Single-keyed locks require one (1); double-keyed locks require two (2).
- c. For information about cores and keys, see the *Core and Key Service Manual*.
- d. To order the kit that contains the throw member, insert, and support ring for use with Schlage, Corbin, KA, KD, and OB cores, use number 1770527.
- e. To order the kit that contains the throw member, insert, and support ring for use with Medeco cores, use number 1778196.

**Non-interchangeable cylinders parts list**

Part no. <sup>a</sup>	Finish	Description
1888913	626	Non-interchangeable cylinder, keyed different
1888955	606	Non-interchangeable cylinder, keyed different
1891329 <sup>b</sup>	626	Non-interchangeable cylinder, keyed alike
1891287 <sup>a</sup>	606	Non-interchangeable cylinder, keyed alike
1888756	626	Non-interchangeable cylinder, zero-bitted
1888798	606	Non-interchangeable cylinder, zero-bitted

- a. The throw members shipped with non-interchangeable cylinders are incompatible with 9K Series Locks. Refer to *Lever components for use with non-interchangeable cores parts list* above to select the appropriate throw member.
- b. Contains a set of 4 cylinders.

## Dummy trim

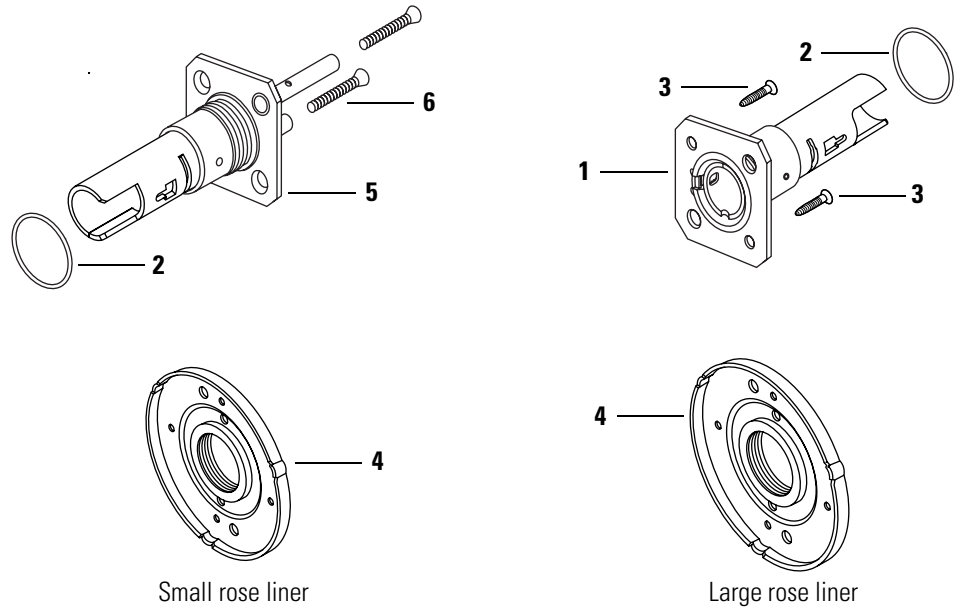

Figure 2.42 Dummy trim parts

### Single dummy trim parts list



Item	Part No.	Qty.	Description
1	B55067	1	Chassis sub-assembly
2	A54465	1	“O” ring
3	A39217	2	#8 × 1 PFH type AB screw
4	B55051	1	Small liner and ring assembly <i>or</i>
	B55050	1	Large liner and ring assembly

### Double dummy trim parts list

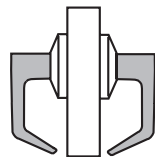

Item	Part No.	Qty.	Description
1	B55239	1	Chassis sub-assembly
2	A54465	2	“O” ring
4	B55051	2	Small liner and ring assembly <i>or</i>
	B55050	2	Large liner and ring assembly
5	B55067	1	Chassis sub-assembly
6	A18991	2	#8-32 × 1 1/8 Phil. FHMS screw

**Latches**

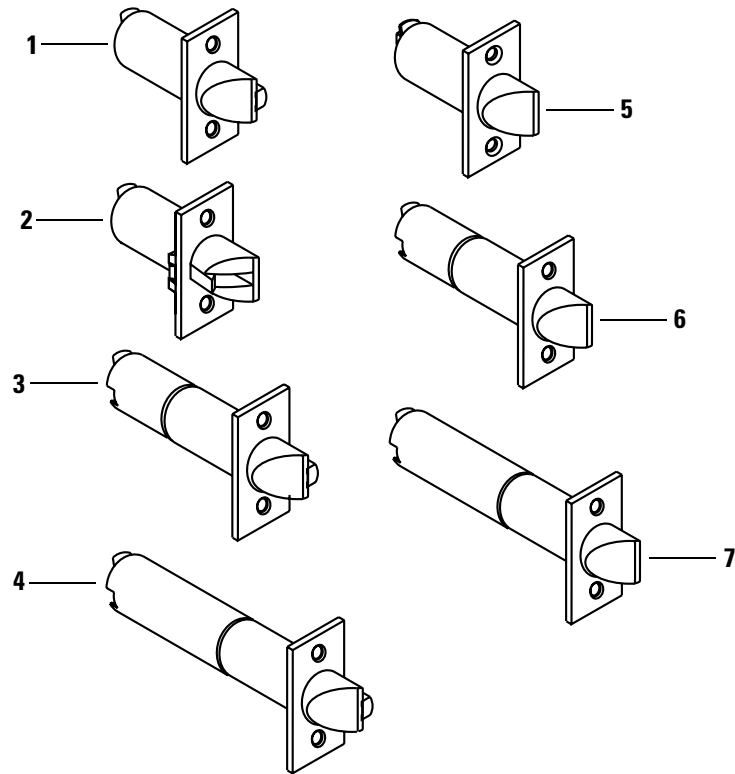
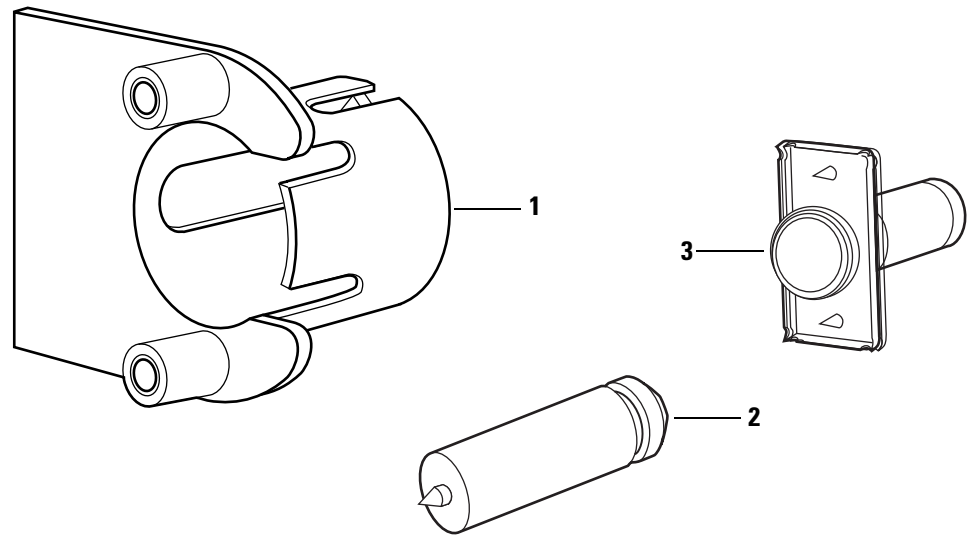

**Figure 2.43** Latches

**Latches parts list**

Item	Latch type	Backset	Part no.	Nomenclature	Description
1	Deadlocking	2 3/4"	C54680	8KL3	Latch
2	Deadlocking	2 3/4"	A54661	N/A	Latch with 3/4" throw
3	Deadlocking	3 3/4"	C54682	8KL4	Latch
4	Deadlocking	5"	C54684	8KL5	Latch
5	Spring	2 3/4"	C54681	8KSL3	Latch
6	Spring	3 3/4"	C54683	8KSL4	Latch
7	Spring	5"	C54685	8KSL5	Latch

**Installation tools**



**Figure 2.44** Installation tools

**Installation tools parts list**

<b>Item</b>	<b>Nomenclature</b>	<b>Part no.</b>	<b>Description</b>
1	KD303	C55034	Drill jig
2	KD325	A01514	Strike plate locating pin
3	KD315	1350393	Faceplate marking chisel

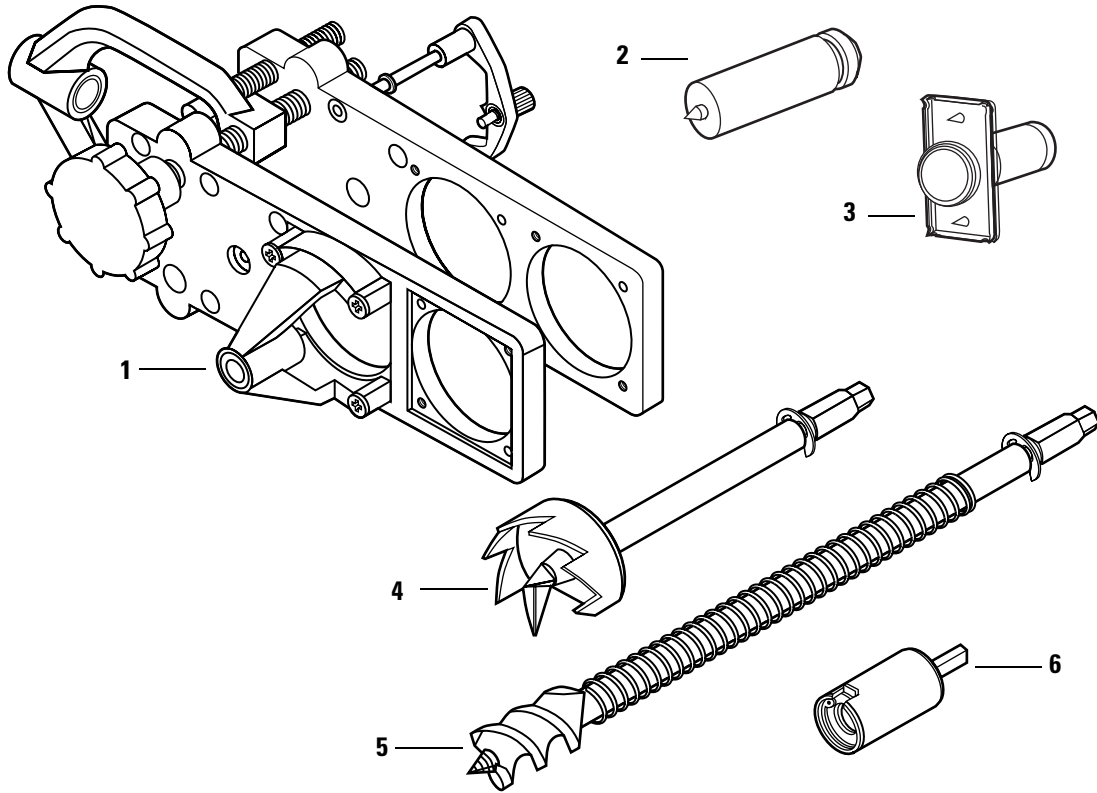

Figure 2.45 Boring jig kit

**Boring jig kit parts list**

Item	Nomenclature	Part no.	Description
1	N/A	N/A	Boring jig <sup>a</sup>
2	KD325	A01514	Strike plate locating pin
3	KD315	1350393	Faceplate marking chisel (1 1/8" × 2 1/4")
not shown	KD312	1487975	Faceplate marking chisel (1" × 2 1/4")
4	KD309	A54084	2 1/8" diameter chassis hole bit assembly
5	KD318	A54085	1" diameter drill bit assembly
6	N/A	N/A	Adaptor for 3/8" drill chuck <sup>a</sup>
1-6	KD304A	N/A	Boring jig kit

a. Can only be ordered as part of the KD304A boring jig kit.



# 3

---

---

## SERVICE AND MAINTENANCE

This chapter contains instructions for removing and replacing components, servicing and maintaining components, and troubleshooting common questions.

<b>To</b>	<b>See page</b>
Replace levers	<a href="#">3-3</a>
Replace roses	<a href="#">3-4</a>
Replace the RQE rose liner	<a href="#">3-7</a>
Replace button assemblies	<a href="#">3-8</a>
Replace the lever keeper spring	<a href="#">3-10</a>
Replace the lever return spring	<a href="#">3-11</a>
Replace the key release cam assembly	<a href="#">3-15</a>
Replace the spring drive plate	<a href="#">3-16</a>
Replace the sleeve assembly	<a href="#">3-17</a>
Replace the solenoid	<a href="#">3-19</a>
Lubricate cores	<a href="#">3-19</a>
Add the RQE switch to a function	<a href="#">3-19</a>
Reverse the solenoid when changing functions	<a href="#">3-20</a>
Align chassis and trim	<a href="#">3-19</a>
Position the locking cam for C function locks	<a href="#">3-22</a>
Position the locking cam for G and IN function locks	<a href="#">3-23</a>
Use the emergency key for H and HJ function locks	<a href="#">3-24</a>
Troubleshoot common problems	<a href="#">3-25</a>

## MAINTENANCE TOOLS

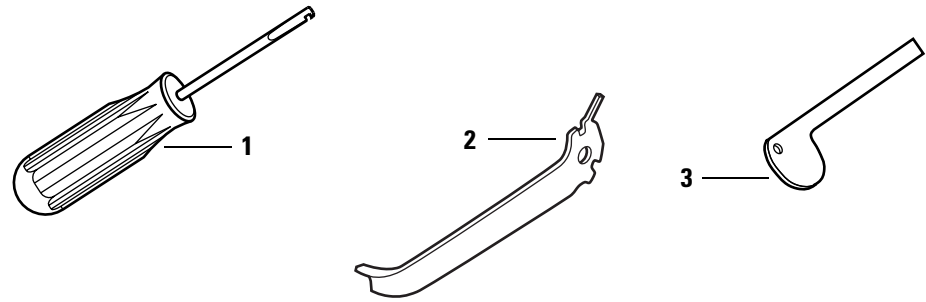

**Figure 3.1** Maintenance tools

### Maintenance tools parts list

Item	Nomenclature	Part no.	Description
1	KD340	N/A	Spring loading tool
2	KD317	C55506	Spanner wrench
3	N/A	A25586	Emergency driver <sup>a</sup>

a. For use with hotel function locks (H and HJ).

## REPLACING PARTS

### Replacing the lever

#### To remove the keyed lever:

1. Insert the control key into the core and rotate the key 15 degrees to the right.
2. Remove the core and throw member from the lever.
3. Insert a flat blade screwdriver into the figure-8 core hole and into the lever keeper.
4. Press the screwdriver blade in the direction of the arrow in [Figure 3.2](#).

**Note:** You will not be able to remove the lever if the screwdriver blade is inserted too far past the keeper.

5. Slide the lever off the sleeve.

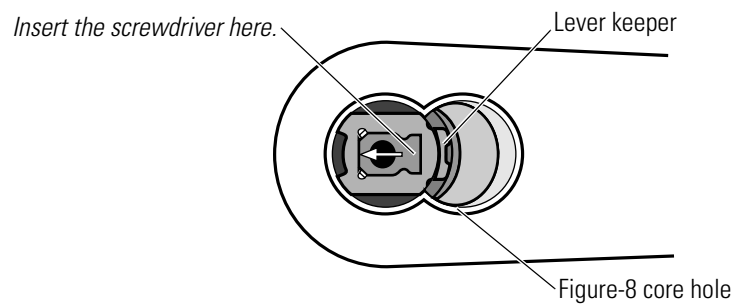

**Figure 3.2** Removing the keyed lever

#### To remove the plain lever or button lever:

1. Insert the protrusion on the spanner wrench into the hole on the shaft of the lever, as shown in [Figure 3.3](#). Slide the lever off the sleeve.

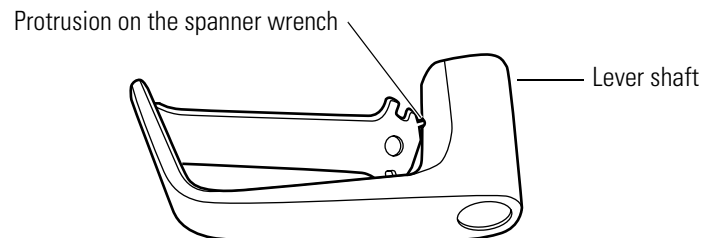
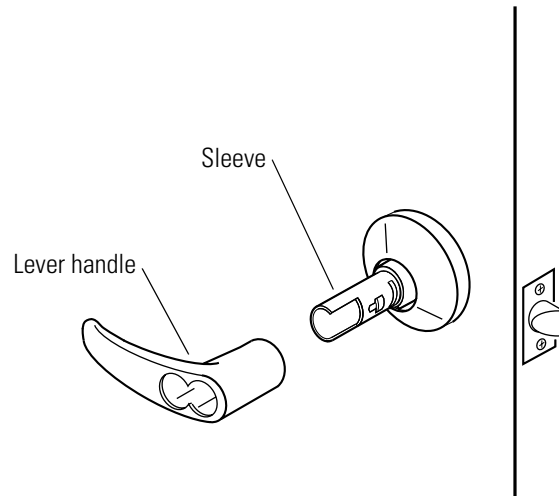

**Figure 3.3** Removing the plain lever or button lever

#### To reinstall the lever:

1. Position the lever so that the handle points toward the door hinges.
2. Slide the lever onto the sleeve and firmly push on the lever until it is seated.

3. Turn the levers to check that they operate smoothly.



**Figure 3.4** Replacing the lever (keyed lever shown)

4. If the lever is keyed, insert the control key into the core and rotate the key 15 degrees to the right. Using the control key, insert the core and throw member into the lever. Rotate the control key 15 degrees to the left and remove the key.

**Replacing the  
inside rose and  
rose liner**

**To remove the inside rose and rose liner:**

1. Remove the inside lever ([page 3-3](#)).
2. Insert the solid, curved end of the spanner wrench in between the rose and the sleeve, as shown in [Figure 3.5](#). Pry the rose until it pops off of the liner.

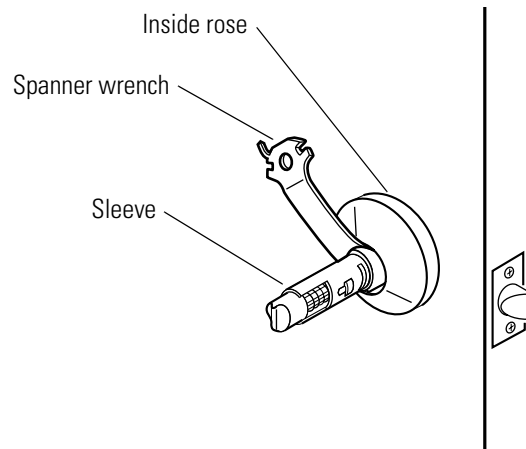

**Figure 3.5** Removing the inside rose with the spanner wrench

3. Unscrew the two through-bolts, as shown in [Figure 3.6](#). Save the through-bolts.

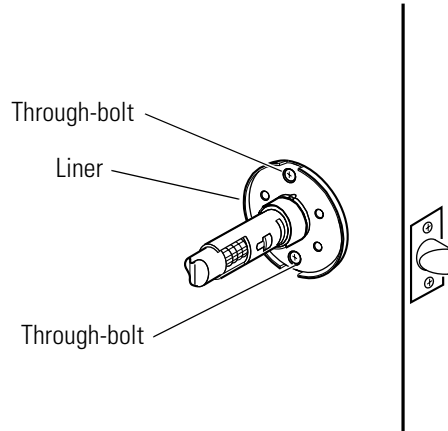
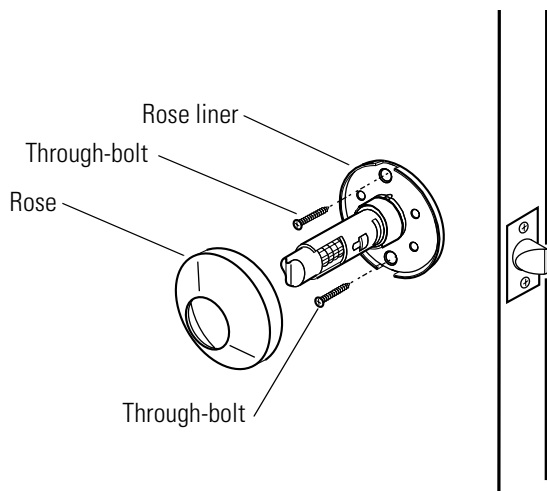

**Figure 3.6** Removing the two through-bolts

4. *If there is an RQE rose liner, disconnect it.*
5. Slide the liner off of the sleeve.

**To reinstall the inside rose and rose liner:**

1. Align the holes in the liner with the holes prepared in the door.
2. Install the two through-bolts through the liner and door in the top and bottom holes.
3. Tighten the liner onto the door with the through-bolts.
4. *If there is an RQE rose liner, connect it.*
5. Install the rose.
6. Reinstall the lever. See [page 3-3](#)

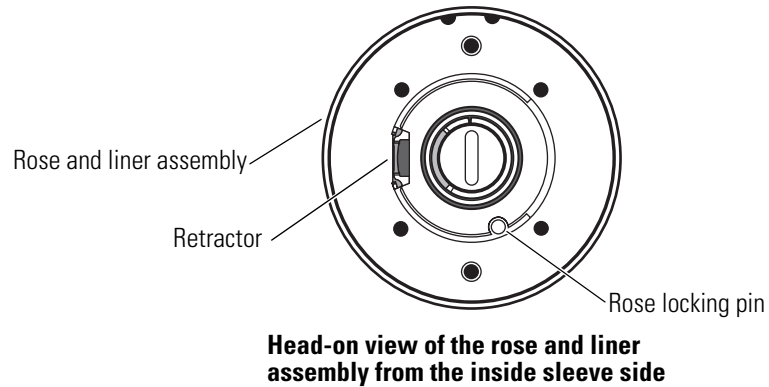
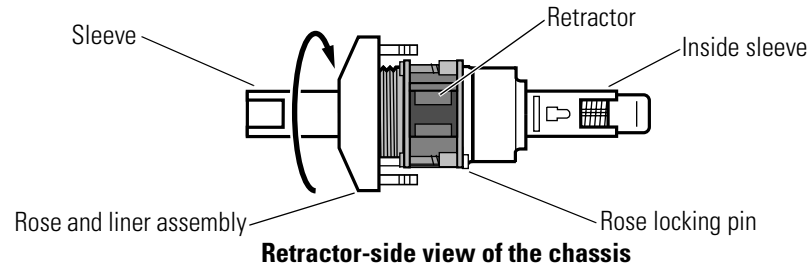

**Figure 3.7** Replacing the inside rose and rose liner

**Replacing the  
outside rose  
and liner  
assembly**

**To remove the outside rose and liner assembly:**

1. Remove the following components:
  - levers (page 3-3)
  - inside rose and rose liner (page 3-4).
2. Slide the chassis assembly out of the door.
3. Retract the rose locking pin, and rotate the rose and liner assembly counterclockwise until it is free from the hub.
4. Remove the rose and liner assembly from the sleeve.



**Figure 3.8** Removing the outside rose and liner assembly

**To reinstall the outside rose and liner assembly:**

1. Retract the rose locking pin, and rotate the rose and liner assembly clockwise until the proper door thickness groove on the through-bolt stud lines up with the hub face.

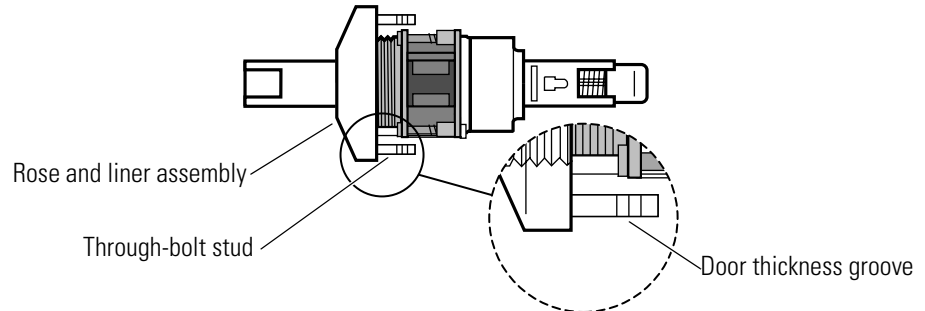

**Figure 3.9** Replacing the outside rose and liner assembly

2. Release the rose locking pin. It should lock into the rose liner.
3. Install the lock chassis assembly from the outside. Make sure the latch tabs engage the chassis frame and the latch tailpiece engages the retractor.
4. Reinstall the following components:
  - inside rose and rose liner (page 3-5)
  - levers (page 3-3).

**Replacing the RQE rose liner for electrified locks**

**To remove the RQE rose liner:**

1. Remove the following components:
  - levers (page 3-3)
  - inside rose and rose liner (page 3-4).
2. Disconnect the RQE connector.
3. Remove the through-bolts and the RQE rose liner.

**To reinstall the RQE rose liner:**

1. Place the RQE rose liner on the chassis, aligning the holes in the rose liner with the holes prepared in the door.

*Make sure that there is clearance for the solenoid wire between the RQE rose liner and the door.*



2. Install the through-bolts through the RQE rose liner and door in the top and bottom holes.
3. Tighten the RQE rose liner on the door with the through-bolts.
4. Connect the RQE connector.

5. Reinstall the following components:
  - inside rose and rose liner (page 3-5)
  - levers (page 3-3).

**Replacing the  
button  
assembly**

**To remove the button assembly:**

**Note:** These instructions apply for all types of button assemblies.

1. Remove the following components:
  - levers (page 3-3)
  - roses and rose liners (page 3-4 or page 3-6).
2. Use a flat screwdriver to press down on the button assembly tab, which is visible through the cutout in the sleeve. The tab should now lie flat.

**Note:** When performing this step, it is best to position the lock on a flat surface so that the retractor faces upward.

3. Press down on the retractor and slide the button assembly out of the sleeve.

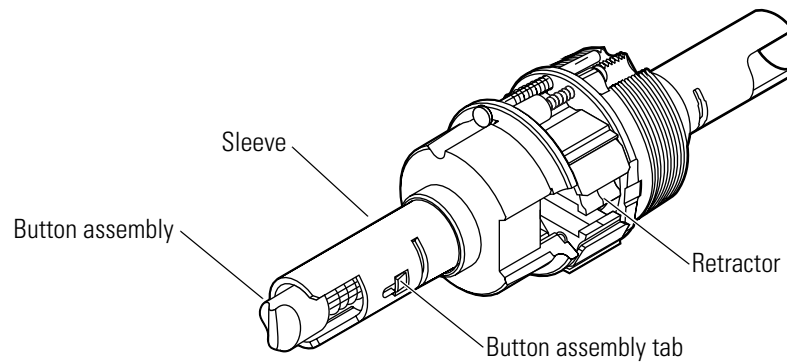

**Figure 3.10** Removing the button assembly



**To reinstall the button assembly:**

1. Insert the new button assembly into the sleeve, as shown in [Figure 3.11](#), until the tab lines up with the cutout in the sleeve. It may be necessary to slightly press in the retractor with your thumb so that the locking bar can properly align itself through the chassis and into the key release cam assembly.

**Note:** The button assembly should not pop out of the sleeve. If it does, it is misaligned and will not function properly.

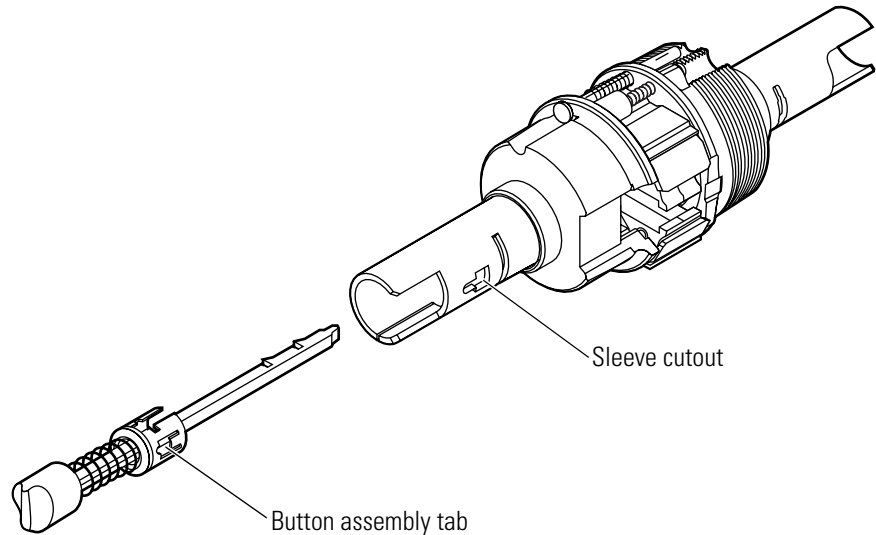

**Figure 3.11** Inserting the button assembly into the sleeve

2. Insert a small screwdriver into the cutout in the sleeve and under the button assembly tab. Bend the tab into the cutout, as shown in [Figure 3.12](#).

**Note:** Do not bend the tab so that it protrudes further than the diameter of the sleeve. It could interfere with the lever function.

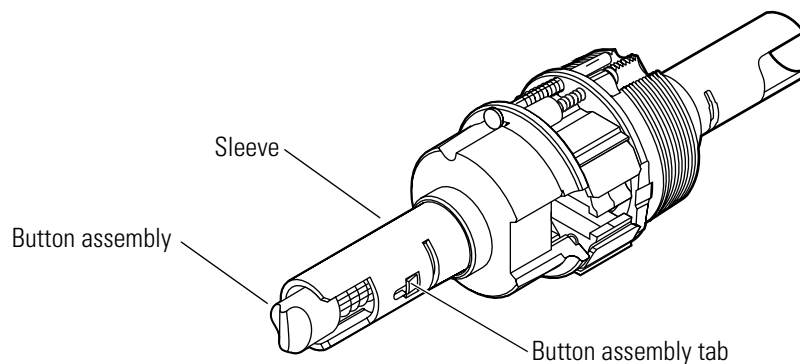

**Figure 3.12** Bending the button assembly tab

3. Reinstall the following components:
  - roses and rose liners (page 3-5 or page 3-7)
  - levers (page 3-3).

**Replacing the lever keeper spring**

**To remove the lever keeper spring:**

1. Remove the following components:
  - levers (page 3-3)
  - roses and rose liners (page 3-4 and page 3-6)
  - button assembly, if present (page 3-8).
2. Using a pair of needle-nosed pliers, reach into the sleeve and remove the lever keeper spring, as shown in Figure 3.13.

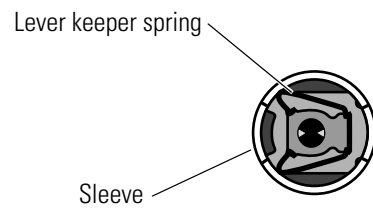

**Figure 3.13** Removing the lever keeper spring

**To reinstall the lever keeper spring:**

1. Position the lever keeper spring as shown in Figure 3.14.

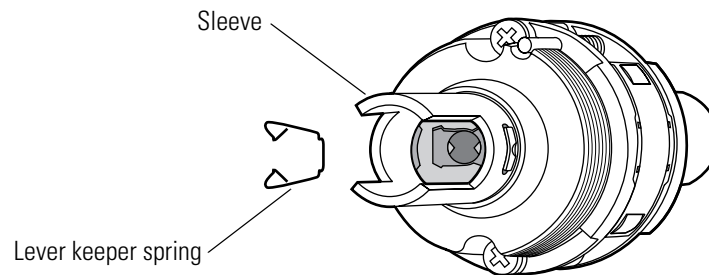

**Figure 3.14** Positioning the lever keeper spring

2. Use a pair of needle-nosed pliers to insert the lever keeper spring into the sleeve. Using the pliers, work the spring into position so that the spring is gripping the lever keeper. See [Figure 3.15](#).

**Note:** If the lever keeper spring is not installed correctly, the lever may fall off of the chassis.

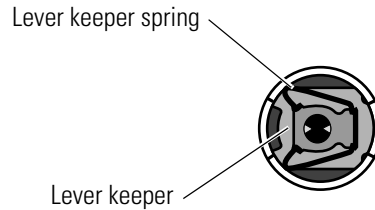

**Figure 3.15** Lever keeper spring in position

3. Reinstall the following components:
  - button assembly, if present ([page 3-9](#))
  - roses and rose liners ([page 3-5](#) and [page 3-7](#))
  - levers ([page 3-3](#)).

### Replacing the lever return spring



### To remove the lever return spring:

*Use extreme caution when performing the steps below. Point the lever return spring away from you while disassembling the lock. The lever return spring may unexpectedly pop out and could injure you.*

1. Remove the following components:
  - levers ([page 3-3](#))
  - roses and rose liners ([page 3-4](#) and [page 3-6](#))
  - button assembly, if present ([page 3-8](#)).

2. Remove the two chassis screws shown in [Figure 3.16](#), and separate the hub and sleeve assembly from the rest of the chassis. Save the two screws.

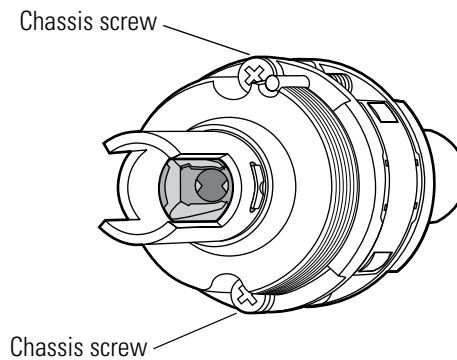

**Figure 3.16** Separating the hub and sleeve assembly from the chassis

3. Raise the key release cam assembly or non-keyed sleeve assembly slightly, and slide the thrust plate out from under it. See [Figure 3.17](#).

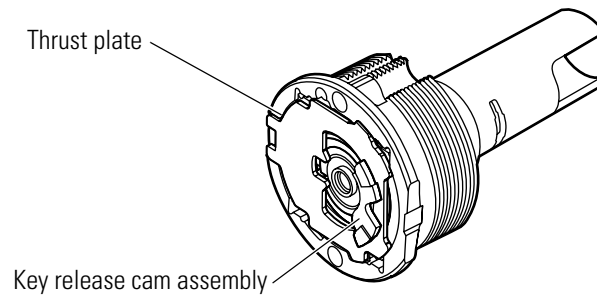

**Figure 3.17** Removing the thrust plate

4. Pull the end of the lever return spring up and over the raised edge on the spring drive plate or non-keyed sleeve. See [Figure 3.18](#).

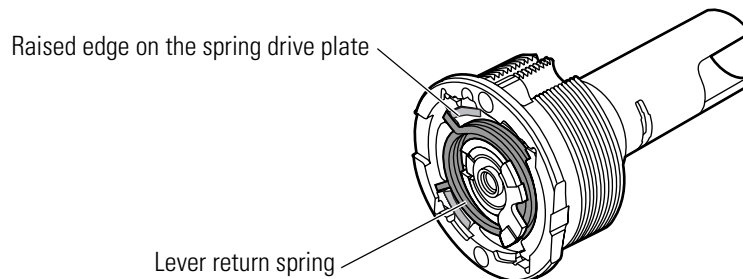

**Figure 3.18** Removing the lever return spring

**To reinstall the lever return spring:**

1. Position the lever return spring so that the flat section of the spring faces toward the hub, as shown in [Figure 3.19](#).

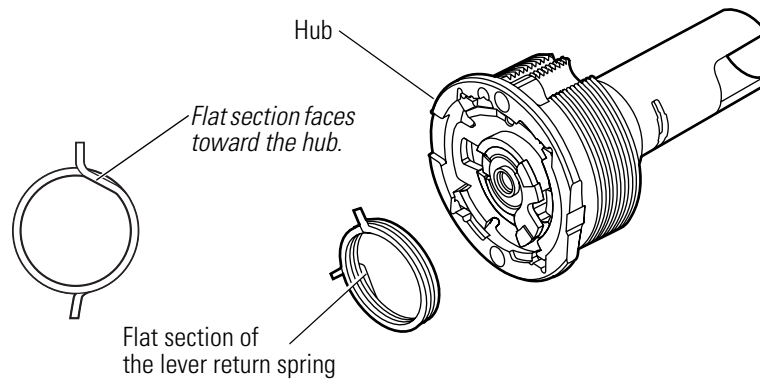
**Figure 3.19** Positioning the lever return spring

2. Raise the key release cam assembly or non-keyed sleeve assembly slightly, and insert the lever return spring so it fits under the ears on the key release cam assembly or non-keyed sleeve assembly. The bottom end of the lever return spring should line up with the edge of the recess in the hub, as shown in [Figure 3.20](#).

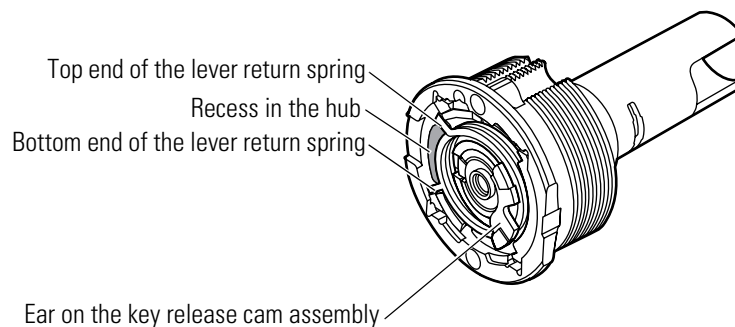
**Figure 3.20** Inserting the lever return spring

3. Use the KD340 spring loading tool or a pair of needle-nosed pliers to pull the top end of the lever return spring around to rest against the other edge of the recess in the hub, as shown in [Figure 3.20](#).

**Note:** Make sure that the lever return spring does not separate and ride onto the top of the sleeve.

4. Raise the key release cam assembly or non-keyed sleeve assembly slightly, and insert the flat end of the thrust plate under the ears, as shown in [Figure 3.21](#). The plate should be flush with the top of the hub.

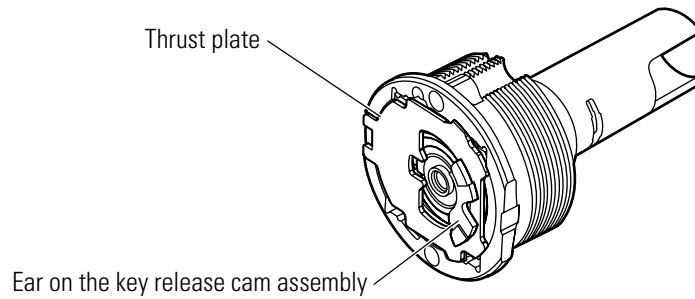

**Figure 3.21** Installing the thrust plate

5. Slide the chassis cover over the retractor assembly.
6. Align the open end of the retractor assembly with the ears on the key release cam assembly in the inside hub assembly.
7. Press the retractor toward the retractor springs and insert the feet of the retractor assembly into the notches in the inside hub, as shown in [Figure 3.22](#).

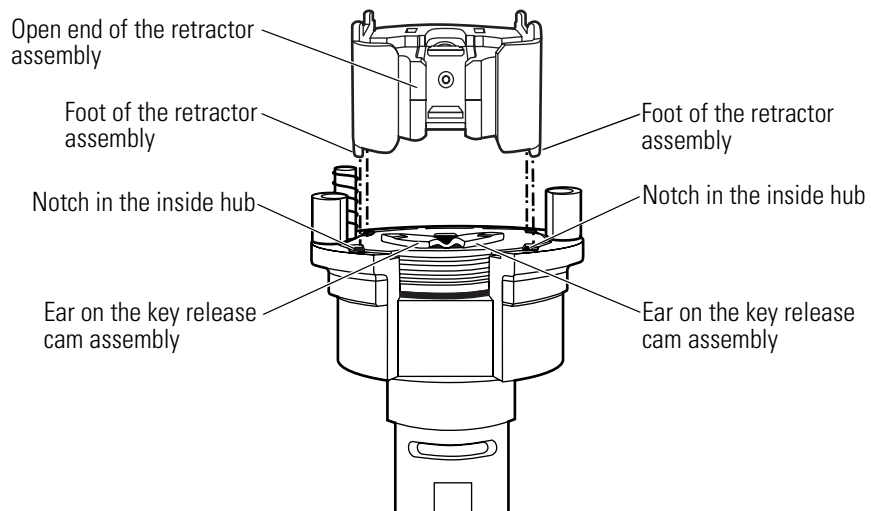

**Figure 3.22** Positioning the retractor assembly

8. Align the feet of the retractor assembly with the notches in the outside hub assembly, and the rose locking pin with the smaller of the two holes on the outside assembly, as shown in [Figure 3.23](#). Press the retractor toward the retractor springs and slide the two sections together.

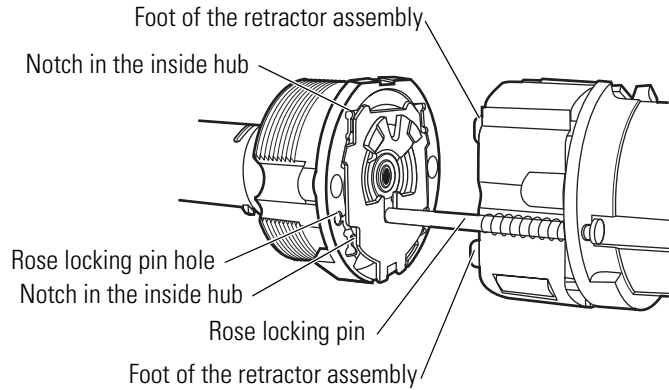

**Figure 3.23** Installing the retractor assembly

9. Install the two chassis screws.
10. Reinstall the following components:
  - button assembly, if present ([page 3-9](#))
  - roses and rose liners ([page 3-5](#) and [page 3-7](#))
  - levers ([page 3-3](#)).

### Replacing the key release cam assembly

#### To remove the key release cam assembly:

1. Remove the following components:
  - levers ([page 3-3](#))
  - roses and rose liners ([page 3-4](#) and [page 3-6](#))
  - button assembly, if present ([page 3-8](#))
  - lever return spring ([page 3-11](#)).
2. Pull the key release cam assembly out of the sleeve.

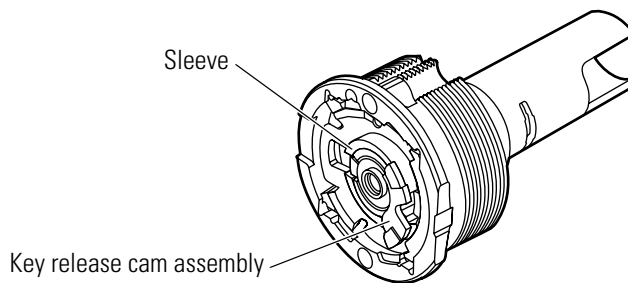

**Figure 3.24** Removing the key release cam assembly

**To reinstall the key release cam assembly:**

1. Insert the key release cam assembly into the sleeve so that the locking lug fits into the notch in the sleeve and spring drive plate. See [Figure 3.25](#).

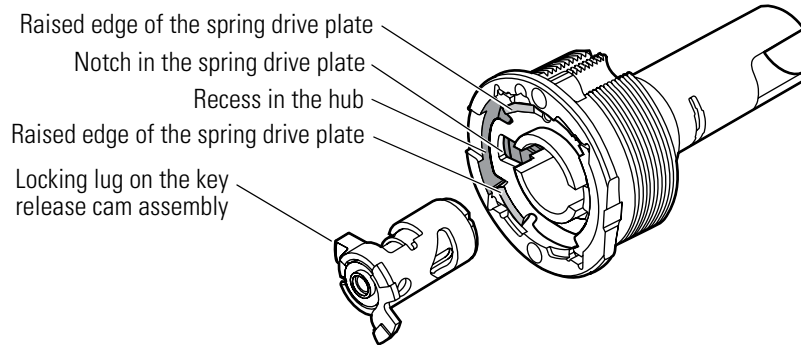

**Figure 3.25** Installing the key release cam assembly

2. Make sure that the raised edges of the spring drive plate line up with the recess in the hub, as shown in [Figure 3.25](#).
3. Reinstall the following components:
  - lever return spring ([page 3-13](#))
  - button assembly, if present ([page 3-9](#))
  - roses and rose liners ([page 3-5](#) and [page 3-7](#))
  - levers ([page 3-3](#)).

**Replacing the  
spring drive  
plate**

**To remove the spring drive plate:**

1. Remove the following components:
  - levers ([page 3-3](#))
  - roses and rose liners ([page 3-4](#) and [page 3-6](#))
  - button assembly, if present ([page 3-8](#))
  - lever return spring ([page 3-11](#))
  - key release cam assembly ([page 3-15](#)).
2. Pull the spring drive plate out of the hub, as shown in [Figure 3.26](#).

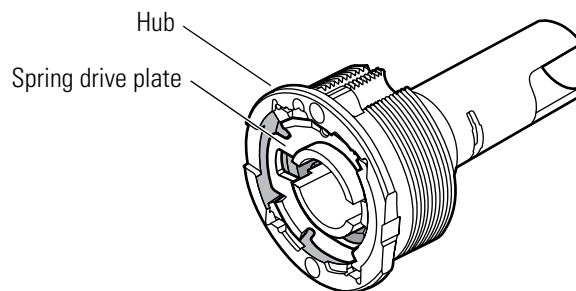
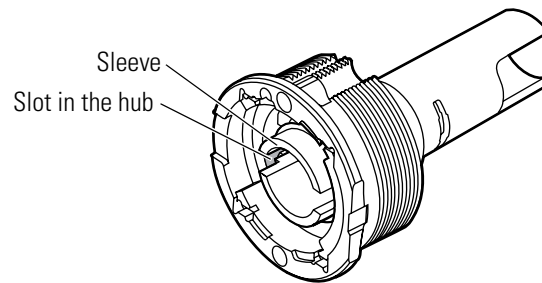

**Figure 3.26** Removing the spring drive plate



**To reinstall the spring drive plate:**

1. Align the sleeve so that the deep slot in the sleeve lines up with the slot in the hub, as shown in [Figure 3.27](#).



**Figure 3.27** Positioning the sleeve

2. Place the spring drive plate over the sleeve as shown in [Figure 3.27](#).

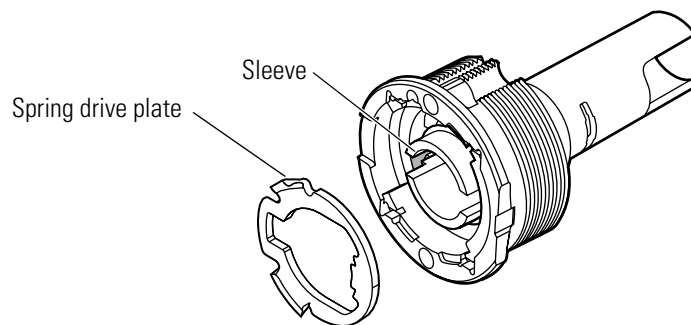

**Figure 3.28** Installing the spring drive plate

3. Reinstall the following components:
  - key release cam assembly ([page 3-16](#))
  - lever return spring ([page 3-13](#))
  - button assembly, if present ([page 3-9](#))
  - roses and rose liners ([page 3-5](#) and [page 3-7](#))
  - levers ([page 3-3](#)).

**Replacing the sleeve assembly**

**To remove the sleeve assembly:**

1. Remove the following components:
  - levers ([page 3-3](#))
  - rose and rose liner ([page 3-4](#) or [page 3-6](#))
  - button assembly, if present ([page 3-8](#))
  - lever return spring ([page 3-11](#))
  - key release cam assembly ([page 3-15](#))
  - spring drive plate ([page 3-16](#)).

2. Press on the lever keeper, which protrudes through the cutout in the sleeve, as shown in [Figure 3.29](#). Pull the sleeve out of the hub, keeping the lever keeper pushed in until it clears the hub.

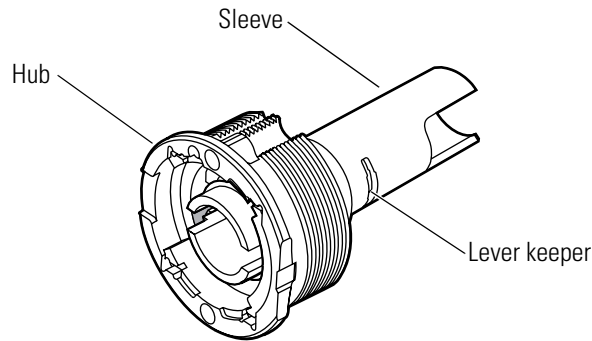

**Figure 3.29** Removing the sleeve assembly from the hub

**To reinstall the sleeve assembly:**

1. Insert the sleeve through the hub as far as possible.
2. Insert a flat blade screwdriver through the sleeve and into the lever keeper.
3. Press the screwdriver blade in the direction of the arrow in [Figure 3.30](#). Push the sleeve the rest of the way through the hub.

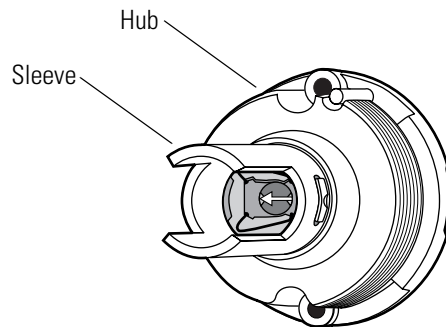

**Figure 3.30** Replacing the sleeve assembly

4. Align the sleeve so that the deep slot in the sleeve lines up with the slot in the hub, as shown in [Figure 3.31](#).

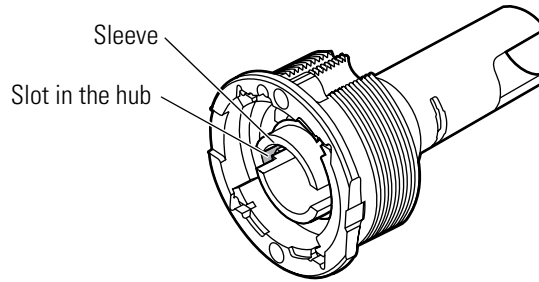

**Figure 3.31** Positioning the sleeve

5. Reinstall the following components:
  - spring drive plate ([page 3-17](#))
  - key release cam assembly ([page 3-16](#))
  - lever return spring ([page 3-13](#))
  - button assembly, if present ([page 3-9](#))
  - rose and rose liner ([page 3-5](#) or [page 3-7](#))
  - levers ([page 3-3](#)).

### Replacing the solenoid for electrified locks

Because of the complex nature of this procedure, BEST recommends that you order a new cylindrical chassis. Contact your BEST representative.

Use the part numbers listed in *Reversing the solenoid when changing the function* when ordering a new cylindrical chassis. See [page 3-20](#).

## ADDING THE RQE SWITCH TO ELECTRIFIED LOCKS

Because of the complex nature of this procedure, BEST recommends that you order a new electrified function chassis and an RQE rose liner. Contact your BEST representative.

Use the following part numbers when ordering a new electrified function chassis and RQE rose liner.

Chassis type	Part number
9KW DEL	C60245
9KW DEL, for use with non-interchangeable cores	C60334
9KW DEU	C60241
9KW DEU, for use with non-interchangeable cores	C60336

RQE rose liner	Part number
Small	B61049
Large	B60221

## REVERSING THE SOLENOID WHEN CHANGING THE FUNCTION

Because of the complex nature of this procedure, BEST recommends that you order a new electrified function chassis. Contact your BEST representative.

Use the following part numbers when ordering a new electrified function chassis.

<b>Chassis type</b>	<b>Part number</b>
9KW DEL	C60245
9KW DEL (without RQE)	C60244
9KW DEL, for use with non-interchangeable cores	C60334
9KW DEL, for use with non-interchangeable cores (without RQE)	C60333
9KW DEU	C60241
9KW DEU (without RQE)	C60240
9KW DEU, for use with non-interchangeable cores	C60336
9KW DEU, for use with non-interchangeable cores (without RQE)	C60335

## LUBRICATING THE CORES



*Do not lubricate cores with oil. Doing so will only attract dirt.*

### For powdered graphite lubrication:

1. Dip a key in graphite. Insert the key into the keyhole and remove it; repeat several times. *OR*  
Spray graphite into the keyhole. Insert the key into the keyhole and remove it; repeat several times.
2. Allow the graphite to sift into the pin segment holes.

### For silicone type lubrication:

1. Clean all existing lubricant out of the core.



*Do not mix graphite with a silicone-type lubricant.*

2. With the core inverted, spray the lubricant into the key opening allowing the spray to penetrate the pin segment holes.

**Note:** When cores are installed and exposed to harsh weather conditions, silicone-type lubricants can help displace moisture as well as spread into pin segment holes and other surfaces.

## ALIGNING THE CHASSIS AND TRIM

Establish a schedule to inspect locks, doors, and door hardware for proper alignment and operation. Occasionally a lock chassis and/or rose trim may become loose and require tightening.

### To retighten a loose or misaligned chassis or rose trim:

1. Remove the inside trim. See [page 3-4](#) for instructions.
2. Align the chassis with the latch. Make sure that the latch tabs engage the chassis frame and the latch tailpiece engages the retractor, as shown in [Figure 3.32](#).

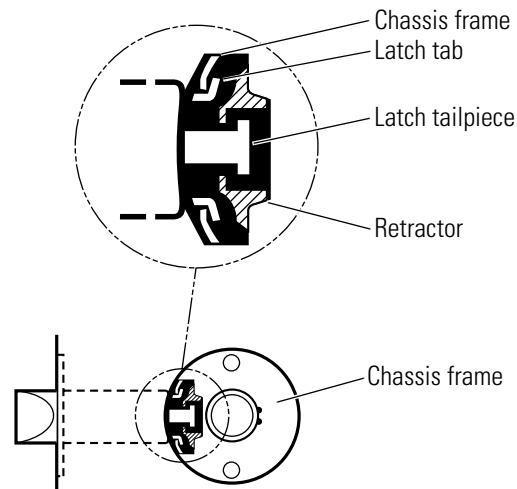

**Figure 3.32** Engaging the retractor in the latch

3. Tighten the chassis screws.
4. Test the lever operation to make sure that the latch tailpiece does not bind with the chassis retractor.
5. Reinstall the inside trim. See [page 3-5](#) for instructions.

## CAM POSITIONING INSTRUCTIONS

### Positioning the cam for C function locks

Vibration during the shipment of the C function locks may cause the inside locking cam to rotate out of position. You might notice this problem in one of the following ways.

- The inside key does not rotate the full 360° and the outside key does not rotate the full 135°. Remove the inside core and throw member, and perform the steps below to reposition the inside locking cam.
- Before you install the core and throw member, you can see that the inside locking cam is not positioned as shown in [Figure 3.33](#). Perform the following steps to reposition the inside locking cam.

### To reposition the locking cam:

1. Looking into the figure-8 core hole in the inside lever, turn the locking cam ears counterclockwise to match the position shown in [Figure 3.33](#).

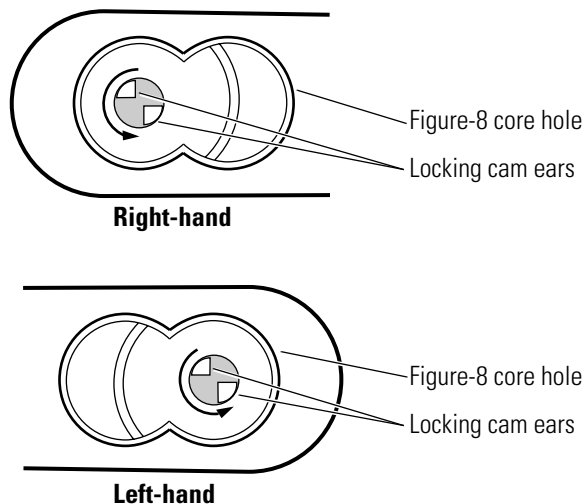

**Figure 3.33** Correct position of the C function inside locking cam

2. Install the core and throw member.
3. Check the operation of the levers while the door is open. The outside lever is locked by rotating the inside key 360° counterclockwise and unlocked by rotating the inside key 360° clockwise.

### Positioning the cam for G and IN function locks

Vibration during the shipment of the G and IN function locks may cause the inside locking cam to rotate out of position. You might notice this problem in one of the following ways.

- With the levers in the locked position, both the inside and outside keys do not rotate one full turn in both directions. Remove both cores and throw members, and perform the following steps to reposition the locking cam.
- Before you install the core and throw member, you can see that the locking cam is not positioned as shown in [Figure 3.34](#). Perform the following steps to reposition the locking cam.

#### To reposition the locking cam:

1. Looking through the figure-8 core hole in either lever, turn the locking cam drive slot to match the position shown in [Figure 3.34](#).
2. Reinstall that lever's core and throw member.
3. Looking into the figure-8 core hole in the other lever, turn the locking cam drive slot counterclockwise until it stops, as shown in [Figure 3.35](#).
4. Turn the drive slot clockwise to match the position shown [Figure 3.34](#).

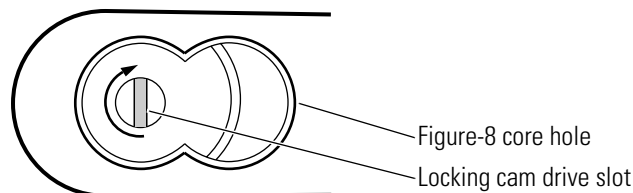

**Figure 3.34** Correct position of the G and IN function locking cam

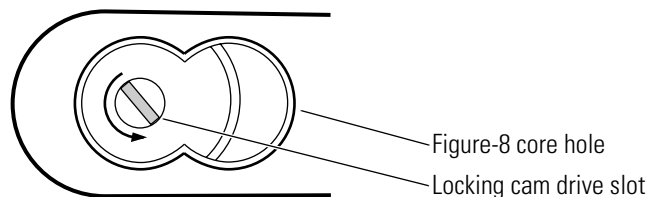

**Figure 3.35** Intermediate position of the G and IN function locking cam

5. Reinstall that lever's core and throw member.
6. Check the operation of the levers while the door is open. The levers are locked by rotating the key 1 1/4 turns counterclockwise and unlocked by rotating the key 1 1/4 turns clockwise.

## EMERGENCY KEY INSTRUCTIONS FOR H AND HJ FUNCTION LOCKS

To use the emergency key:

1. Remove the core and the throw member.
2. Insert the blade of the emergency key into the slot, as shown in [Figure 3.36](#).

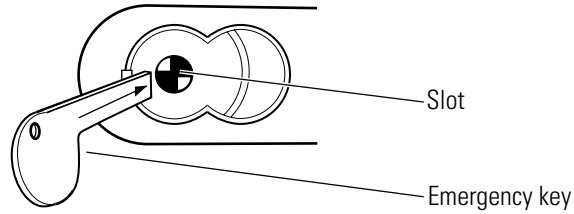

**Figure 3.36** Inserting the emergency key

3. Turn the key and retract the latch.



## TROUBLESHOOTING

This table summarizes the possible causes for certain lock questions. The causes are listed in the order of likelihood. (The most likely cause is first, and so forth.)

You notice...	Possible causes include...	You should...
Lever won't return to its normal position.	<ul style="list-style-type: none"> <li>a. Lever return spring is out of position.</li> <li>b. Lever return spring is broken.</li> <li>c. There is binding between the lever and rose.</li> </ul>	<ul style="list-style-type: none"> <li>a. Reposition the lever return spring (pg. 3-11). Replace the spring drive plate, if damaged (pg. 3-16).</li> <li>b. Replace the lever return spring (pg. 3-11).</li> <li>c. Ensure that the lock chassis is centered within the door (pg. 3-19).</li> </ul>
Key spins freely, but won't retract the latch or unlock the door.	<ul style="list-style-type: none"> <li>a. Throw member is not installed.</li> <li>b. 6-pin core is installed with a 7-pin throw member.</li> </ul>	<ul style="list-style-type: none"> <li>a. Install the throw member.</li> <li>b. Change the core or throw member.</li> </ul>
Core doesn't fit into the lever core hole.	<ul style="list-style-type: none"> <li>a. 7-pin core is installed with a 6-pin throw member.</li> <li>b. Keyed lever is defective.</li> </ul>	<ul style="list-style-type: none"> <li>a. Change the core or throw member.</li> <li>b. Replace the keyed lever (pg. 3-3).</li> </ul>
Button doesn't pop out as expected.	Button shaft is damaged or bent.	Replace the button assembly (pg. 3-8).
Latch doesn't retract.	<ul style="list-style-type: none"> <li>a. Latch tailpiece is broken.</li> <li>b. Latch tailpiece didn't engage the retractor correctly during installation.</li> </ul>	<ul style="list-style-type: none"> <li>a. Replace the latch assembly.</li> <li>b. Reinstall the lock chassis (pg. 3-6).</li> </ul>
For a C function lock, the inside key does not rotate the full 360°, and the outside key does not rotate the full 135°.	Inside locking cam is out of position.	Reposition the inside locking cam (pg. 3-22).
For a G or IN function lock with levers in the locked position, the key does not rotate one full turn in both directions.	Locking cam is out of position.	Reposition the locking cam (pg. 3-22).
Cannot remove the operating key from an H or HJ function lock.	Key is turned 180° past the correct position.	Push the inside button, turn the key back clockwise 180°, and remove the key.



# A

---

---

## INSTALLATION INSTRUCTIONS

The following pages contain the *Installation Instructions for 9K Cylindrical Locks* and the *Wiring Instructions for 8K & 9K Series Electrified Cylindrical Locks*.



## For factory-prepared doors only

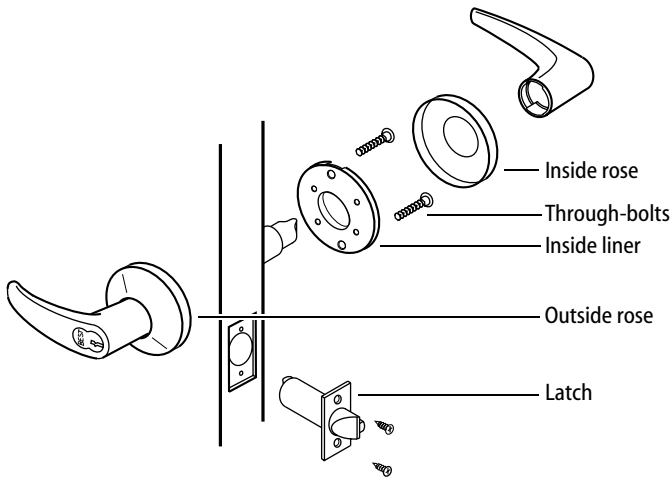

Figure 1 — Overview diagram

**Caution:** If you use hollow metal doors, determine whether the doors are reinforced enough to support the lock. If door reinforcement is not adequate, consult the door manufacturer for information on proper reinforcement.

### Simplified instructions

- 1 Install the latch so that the bevel on the latchbolt faces the strike.
- 2 Adjust the outside rose assembly so that the chassis is centered in the door. Install the chassis from the outside of the door.
- 3 Install the inside liner, through-bolts, rose, lever and strike.

For field door preparation and detailed installation instructions, see the following tasks.

## 1 Position template

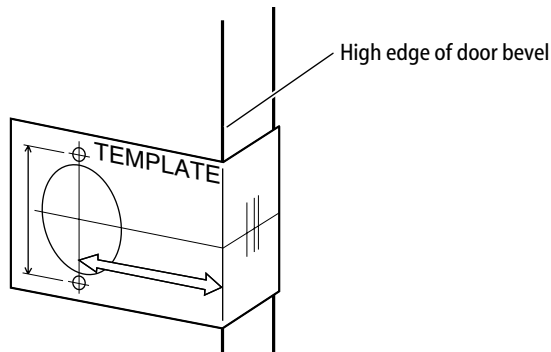

Figure 2 — Placing the template on the high side of the door bevel

- 1 Fold the template and place in position on the high edge of the door bevel (see Figure 2).
- 2 Mark the drill points.

**Note:** Suggested height from floor to centerline of the lock is 40 5/16". If steel frames are used, the latch centerline must be in line with the center of the strike preparation.

## 2 Bore two holes and install latch

- 1 Bore a 2 1/8" diameter hole from both sides of the door, to the center of the door.
- 2 Drill a 1" diameter hole from the edge of the door that intersects the 2 1/8" hole.
- 3 Mortise the door edge for the latch face.
- 4 Install the latch and check the door swing. Latch tabs should project into the 2 1/8" diameter hole. See figure 3 in task 3.

## 3 Install boring jig and drill two 5/16" diameter holes

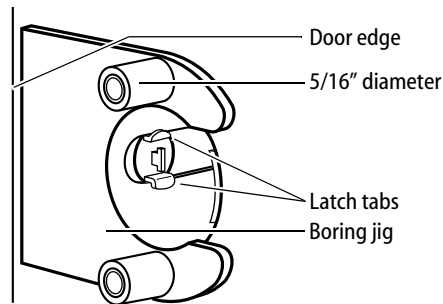

Figure 3 — Positioning the boring jig for drilling the 5/16" holes

- 1 Install the boring jig (KD303) onto the door and engage with latch tabs. Make sure the front edge of the jig is parallel with the door edge (see Figure 3).
- 2 Drill two 5/16" diameter holes halfway into the door.
- 3 Turn the boring jig over and repeat steps one and two from the opposite side of the door.

**Note:** Replace the boring jig after ten door preparations.

## 4 Adjust lockset to door thickness

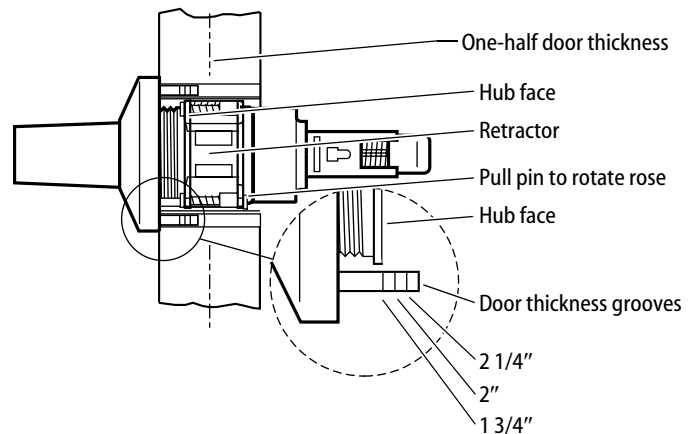

Figure 4 — Adjusting the lock chassis for door thickness

- Pull the rose locking pin and rotate the outside rose liner in or out

until the proper door thickness groove on the through bolt stud, lines up with the hub face (see Figure 4—blow-up).

**Note 1:** Make sure the locking pin locks into the rose liner.

**Note 2:** Locksets will fit doors 1 3/4" to 2 1/4" thick. (A spacer is available for 1 3/8" doors.) See the enlarged view for the correct rose adjustment for these thicknesses.

## 5 Engage retractor in latch

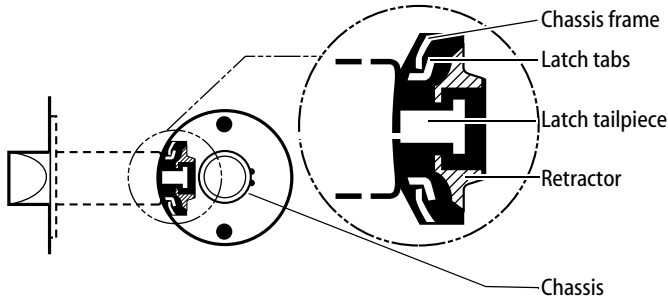

Figure 5 — Engaging the latch and retractor

- With the latch in place, install the chassis from the outside. Make sure the latch tabs engage the chassis frame and the latch tailpiece engages the retractor (see Figure 5).

## 6 Install liner, through-bolts, rose and lever

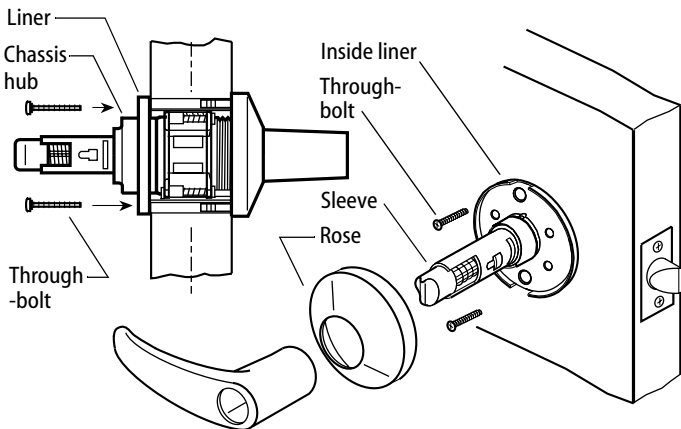

Figure 6 — Installing liner, through bolts, rose, and lever

**Note:** For lead-lined locksets, slide the lead shield (not shown) over the sleeve and into the 2 1/8" hole.

- Align the holes in the liner with the holes prepared in the door.
- Install through-bolts through the liner and door in the top and bottom holes (see Figure 6).
- Tighten the liner onto the door with the through-bolts.
- Slide the rose over the sleeve, then press the rose onto the liner. The rose should fit closely to the door surface.
- With the lever pointing toward the hinges, push the lever on firmly until seated.

## 7 Install strike plate

- In alignment with the center of the latchbolt, mortise the door jamb to fit the strike box and strike plate.

**Caution:** The deadlocking plunger of the latchbolt must not enter the strike plate opening. The plunger deadlocks the latchbolt and prevents forcing the latch when the door is closed. A gap of more than 1/8" may reduce security and/or cause improper operation of the latchbolt.

- Insert the strike box and secure the strike with screws provided (see Figure 7).

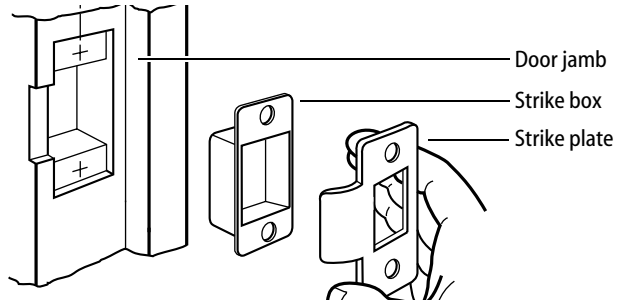

Figure 7 — Installing the strike

## 8 Install core

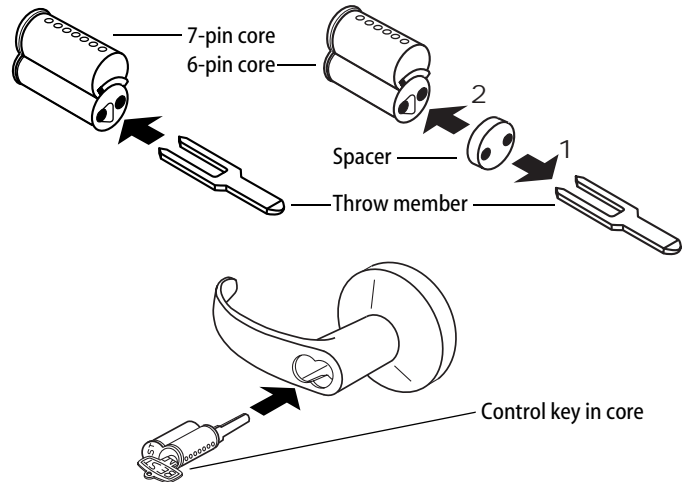

Figure 8 — Installing the core

**For 6-pin core users only:** Slide the spacer — supplied with your 6-pin cores — over the 7-pin throw member (see Figure 8, top right).

**Note:** If you have ordered 6-pin cores, you will get one spacer per core with your order. Spacers are not supplied with locks.

- Insert the throw member (or throw member and spacer) into the back of the core (see Figure 8, top).
- Put the control key into the core and turn the key 15 degrees clockwise.
- Put the core and throw member into the lever with the control key (see Figure 8, bottom).
- Turn the key 15 degrees counterclockwise and remove the key.

**Caution:** Since the control key is a high-security key, make sure to keep it protected.

## Wiring diagram

The diagram below shows how to wire 8K and 9K electrified locks.

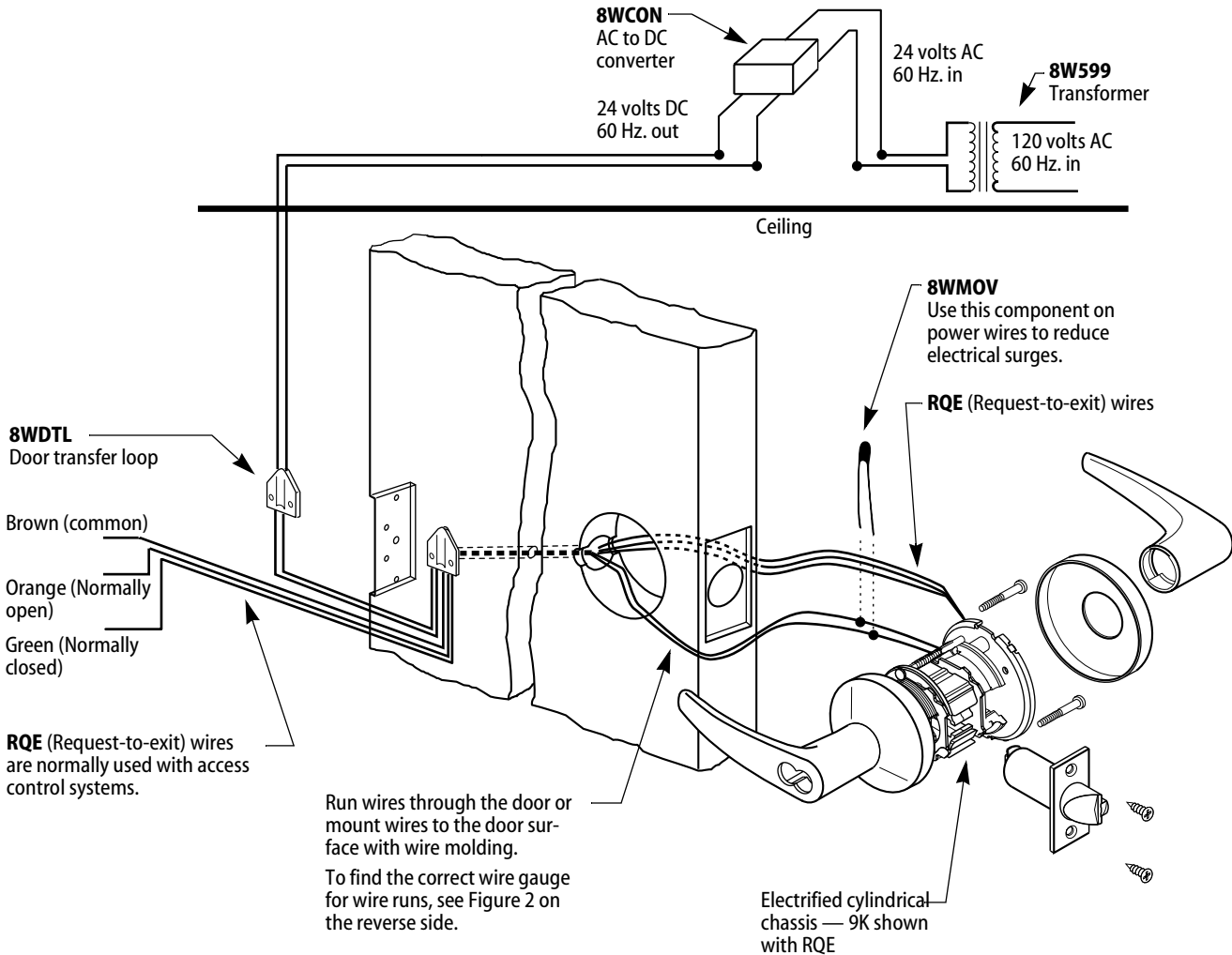

Figure 1—Wiring diagram for 8K and 9K electrified locks (9K with RQE shown)

## Electrical requirements

The following table describes the voltage and current specifications for the 8K and 9K locks, with RQE (REX) switch, and door monitoring switch.

Unit	Voltage	Current
8K (RQE not available)	24 volts DC	0.18 amp continuous duty
9K with and without RQE	24 volts DC	0.169 amp continuous duty
RQE switch	30 volts DC maximum	0.7 amp inductive 0.7 amp resistive

## Parts list

The following table describes the parts illustrated in Figure 1. You may substitute most components with equivalent parts.

Part number	Description
8W599	Transformer—24 volt AC, 40 volt-amps. See the examples under Installation Hints on the reverse side.
8WDTL	Door transfer loop. You may substitute this with a power transfer hinge.
8WMOV	Metal oxide varistor
8WCON	AC to DC converter (full-wave bridge rectifier)

## Minimum gauge wire chart for lock circuits

The chart in Figure 2 helps you find the minimum wire gauge needed for a specific length wire run. It assumes that the lock circuit is made of two conductor cable. The chart also factors in a 15% voltage loss at 24 volts.

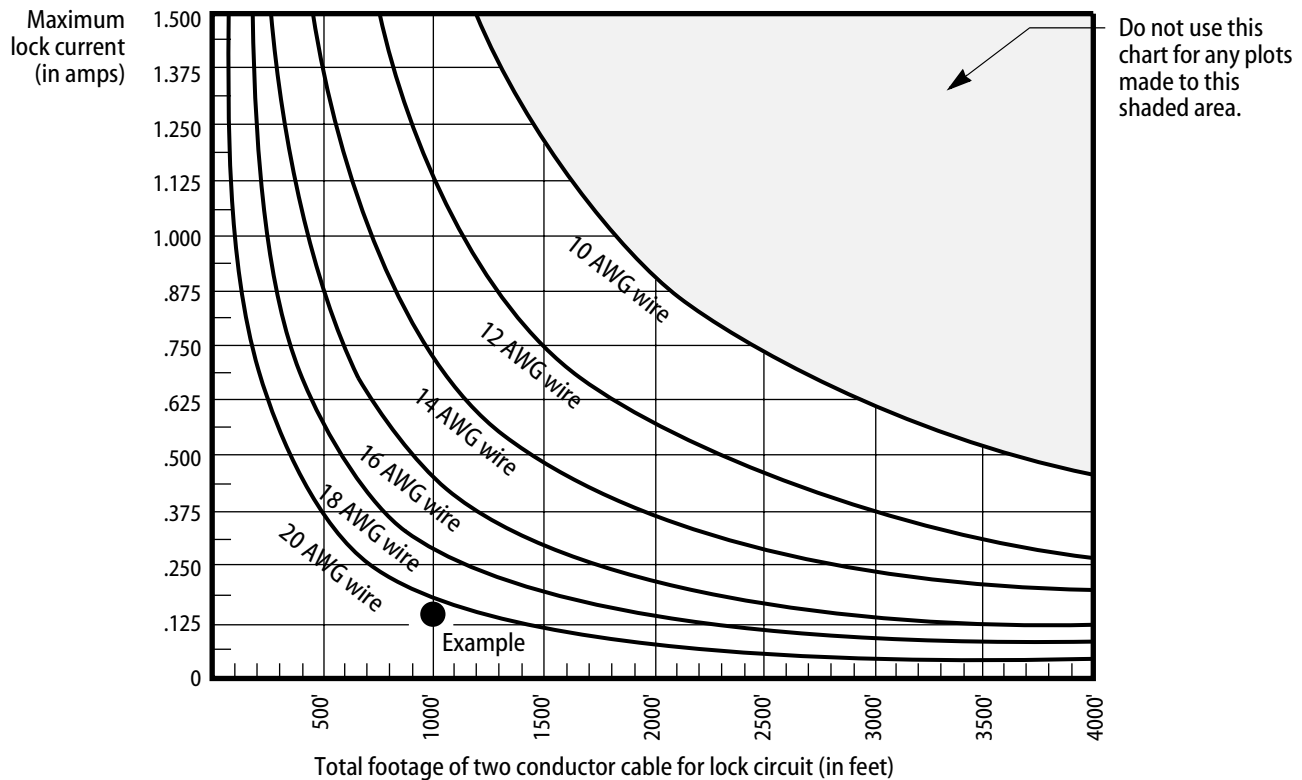

Figure 2—Minimum gauge wire chart for lock circuits

### To find the correct gauge wire

- 1 Determine the maximum lock current and find that value on the left side of the chart.
- 2 Determine the total footage of cable to be used in the lock circuit and find that value at the bottom of the chart.
- 3 Locate the intersection of current and footage. The line above or to the right of the intersection shows what minimum gauge wire you need.

### Example

- ▲ Lock current: 0.169 amp maximum
- ▲ Total wire run: 1000 feet

Wire gauge needed: 20 AWG two conductor cable

**Note:** For 12 volt locks, double the maximum lock current, then use that value on the left side of the chart.

### Installation hints

- 1 Wire gauge (or size) determines how efficiently the lock will operate. Consider wire gauge before installation. To find the recommended minimum wire gauge for all wire runs, see Figure 2.
- 2 Use wire of 20 AWG (gauge) or larger. We do not recommend using a smaller wire gauge than 20 AWG.
- 3 When wiring two or more locks to a single power supply, make sure that the power rating of the power supply is 1 ½ times greater than the sum of the lock's power requirement.

### Example

For two locks powered by one supply:

- ▲ Lock 1 (8K) is rated at 24 volts, 0.18 amps—24 volts × 0.18 amps = 4.32 volt-amps
- ▲ Lock 2 (35H) is rated at 24 volts, 0.75 amps—24 volts × 0.75 amps = 18 volt-amps

Choose a transformer with a rating of at least: (4.32 volt-amps + 18 volt-amps) × 1 ½ = **33.48 volt-amps**



# B

---

---

## INDEX

### A

- A chassis
  - function conversion for 2-49
  - function description for 2-8
  - part numbers and drawings for 2-27
- AB chassis
  - function description for 2-3
  - part numbers and drawings for 2-12
- aligning the chassis and trim 3-21

### B

- B chassis
  - function conversion for 2-49
  - function description for 2-8
  - part numbers and drawings for 2-28
- boring jig kit 2-60
- bridge bar 2-34
- button assembly
  - button release assembly 2-18
  - locking bar assembly for NX function 2-20
  - outside button assembly for LL function 2-33
  - push button assembly 2-17 to 2-18, 2-21, 2-24, 2-28, 2-33
  - slotted button assembly 2-15, 2-31
  - turn button assembly 2-12, 2-27, 2-35
- button bar assembly
  - reinstalling 3-9
  - removing 3-8

### C

- C chassis
  - cam positioning instructions for 3-22
  - function conversion for 2-48
  - function description for 2-5
  - part numbers and drawings for 2-13
- cam positioning instructions
  - for C chassis 3-22
  - for G and IN chassis 3-23
- certifications and standards 1-2
- chassis cover 2-12 to 2-42
  - part numbers for 2-44, 2-46
- chassis frame and retractor assembly
  - part numbers for 2-44, 2-46
- chassis screw 2-12 to 2-42
  - part numbers for 2-44, 2-46
- cores, lubricating 3-20

### D

- D chassis
  - function conversion for 2-48
  - function description for 2-3
  - part numbers and drawings for 2-14
- DEL chassis
  - function description for 2-11
- DEU chassis
  - function description for 2-11
- diagrams, exploded
  - see part numbers and drawings
- disassembling the lock chassis 3-12
- documentation package 1-3
- double dummy trim 2-7, 2-57

DR chassis  
function conversion for 2-49  
function description for 2-9  
part numbers and drawings for 2-29

drawings, of parts  
*see* part numbers and drawings

drill jig 2-59

drive plate  
*see* spring drive plate

DZ chassis  
function conversion for 2-49  
function description for 2-8  
part numbers and drawings for 2-30

## E

E chassis  
function conversion for 2-48  
function description for 2-3  
part numbers and drawings for 2-15

EA chassis  
function conversion for 2-49  
function description for 2-8  
part numbers and drawings for 2-31

emergency driver 3-2

exploded diagrams  
*see* part numbers and drawings

## F

faceplate marking chisel 2-59 to 2-60

function conversion  
reversing the solenoid 3-20

function description  
for A chassis 2-8  
for AB chassis 2-3  
for B chassis 2-8  
for C chassis 2-5  
for D chassis 2-3  
for DEL chassis 2-11  
for DEU chassis 2-11  
for DR chassis 2-9  
for DZ chassis 2-8  
for E chassis 2-3  
for EA chassis 2-8  
for G chassis 2-5  
for H and HJ chassis 2-3  
for IN chassis 2-5  
for L chassis 2-7  
for LL chassis 2-9  
for M chassis 2-10  
for N chassis 2-7

for NX chassis 2-7  
for P chassis 2-7  
for Q chassis 2-10  
for R chassis 2-4  
for RD chassis 2-9  
for RZ chassis 2-9  
for S chassis 2-5  
for T chassis 2-4  
for W chassis 2-6  
for XD chassis 2-9  
for XR chassis 2-9  
for Y chassis 2-7  
for YD chassis 2-9  
for YR chassis 2-9  
for Z chassis 2-10

## G

G chassis  
cam positioning instructions for 3-23  
function conversion for 2-48  
function description for 2-5  
part numbers and drawings for 2-16

## H

H and HJ chassis  
function conversion for 2-48  
function description for 2-3  
key instructions for 3-24  
part numbers and drawings for 2-17

## hub

*see* inside hub assembly *and* outside hub

## hubs

part numbers for 2-44, 2-46

## I

IN chassis  
cam positioning instructions for 3-23  
function conversion for 2-49  
function description for 2-5  
part numbers and drawings for 2-32

inside hub assembly  
inside hub and locking pin assembly 2-12 to 2-29, 2-31 to 2-36, 2-38 to 2-41  
inside hub and locking pin assembly, lost motion 2-32

inside hub and side plate  
assembly 2-30, 2-37, 2-42  
inside hub assembly, lost motion 2-13, 2-16, 2-23, 2-25, 2-29, 2-36, 2-38 to 2-41

## K

key instructions for H and HJ chassis 3-24

key release cam assembly  
part number and drawing for 2-12 to 2-18, 2-20 to 2-25, 2-27 to 2-41  
part numbers for 2-44, 2-46  
reinstalling 3-16  
removing 3-15

keyed sleeve assembly  
part numbers for 2-44, 2-46

knob return spring  
part numbers for 2-44, 2-46

## L

L chassis  
function conversion for 2-48  
function description for 2-7  
part numbers and drawings for 2-18

lead-lined parts 2-51

lever handle insert 2-56

lever keeper spring 2-55, 3-10

lever return spring  
part number and drawing for 2-12 to 2-24, 2-26 to 2-29, 2-31 to 2-37, 2-39, 2-41 to 2-42  
part numbers for 2-44, 2-46  
reinstalling 3-13  
removing 3-11

levers  
part drawings for 2-54  
part numbers for 2-54  
reinstalling 3-3  
removing 3-3

LL chassis  
function conversion for 2-49  
function description for 2-9  
part numbers and drawings for 2-33

lock chassis  
aligning 3-21  
disassembling 3-12  
reassembling 3-14  
reinstalling in the door 3-7

removing from the door 3-6  
locking bar 2-13, 2-16, 2-32  
lubricating cores 3-20

## M

### M chassis

function conversion for 2-49  
function description for 2-10  
part numbers and drawings for 2-34

## N

### N chassis

function conversion for 2-48  
function description for 2-7  
part numbers and drawings for 2-19

### non-keyed sleeve assembly

part numbers for 2-44, 2-46

### non-standard strikes 2-50

### numbers, for parts

see part numbers and drawings

### NX chassis

function conversion for 2-48  
function description for 2-7  
part numbers and drawings for 2-20

## O

### outside hub

outside hub 2-12 to 2-25,  
2-27 to 2-42

outside hub and plate assembly 2-26

outside hub, lost motion 2-12  
to 2-18, 2-20 to  
2-25, 2-27 to 2-34,  
2-36 to 2-39

## P

### P chassis

function conversion for 2-48  
function description for 2-7  
part numbers and drawings for 2-21

### part numbers and drawings

for A chassis 2-27  
for AB chassis 2-12  
for B chassis 2-28  
for C chassis 2-13  
for D chassis 2-14  
for double dummy trim 2-57  
for DR chassis 2-29  
for DZ chassis 2-30

for E chassis 2-15  
for EA chassis 2-31  
for G chassis 2-16  
for H and HJ chassis 2-17  
for IN chassis 2-32  
for L chassis 2-18  
for latches 2-58  
for LL chassis 2-33  
for M chassis 2-34  
for N chassis 2-19  
for non-standard strikes 2-50  
for NX chassis 2-20  
for P chassis 2-21  
for Q chassis 2-35  
for R chassis 2-22  
for RD chassis 2-36  
for roses, rose liners, and rose  
spacers 2-52 to 2-53  
for RZ chassis 2-37  
for S chassis 2-23  
for single dummy trim 2-57  
for standard levers 2-54  
for standard strikes and strike  
boxes 2-50  
for T chassis 2-24  
for W chassis 2-25  
for XD chassis 2-38  
for XR chassis 2-39  
for Y chassis 2-26  
for YD chassis 2-40  
for YR chassis 2-41  
for Z chassis 2-42

## Q

### Q chassis

function conversion for 2-49  
function description for 2-10  
part numbers and drawings for 2-35

## R

### R chassis

function conversion for 2-48  
function description for 2-4  
part numbers and drawings for 2-22

### RD chassis

function conversion for 2-49  
function description for 2-9  
part numbers and drawings for 2-36

reassembling the lock chassis 3-14

### reinstalling

button bar assembly 3-9  
inside rose and rose liner 3-5

key release cam assembly 3-16  
keyed lever 3-3  
lever keeper spring 3-10  
lever return spring 3-13  
lock chassis in the door 3-7  
outside rose and liner assembly 3-7

RQE rose liner 3-7

sleeve assembly 3-18

solenoid 3-19

spring drive plate 3-17

thrust plate 3-14

### removing

button bar assembly 3-8

inside rose and rose liner 3-4

key release cam assembly 3-15

keyed lever 3-3

lever keeper spring 3-10

lever return spring 3-11

lock chassis from the door 3-6

outside rose and liner assembly 3-6

plain lever or button lever 3-3

sleeve assembly 3-17

solenoid 3-19

spring drive plate 3-16

thrust plate 3-12

### retractor assembly

with long catchplate 2-12,  
2-15 to 2-18, 2-21,  
2-24 to 2-25, 2-33

with short catchplate 2-28,  
2-31

without catchplate 2-13 to  
2-14, 2-19 to 2-20,  
2-22 to 2-23, 2-26 to  
2-27, 2-29 to 2-30,  
2-32, 2-34 to 2-42

### RQE rose liner

reinstalling 3-7

### RZ chassis

function conversion for 2-49  
function description for 2-9  
part numbers and drawings for 2-37

## S

### S chassis

function conversion for 2-48  
function description for 2-5  
part numbers and drawings for 2-23

single dummy trim 2-7, 2-57

sleeve assembly  
keyed sleeve and driver  
assembly 2-20  
keyed sleeve assembly 2-12 to 2-18, 2-21 to 2-25, 2-27 to 2-32, 2-35 to 2-41  
keyed sleeve assembly for M function 2-33 to 2-34  
keyed sleeve assembly, non-IC 2-12 to 2-16, 2-22 to 2-25, 2-27 to 2-32, 2-36 to 2-41  
non-keyed sleeve and driver  
assembly 2-12, 2-14 to 2-15, 2-17 to 2-22, 2-24, 2-26 to 2-28, 2-31, 2-33 to 2-35, 2-42  
non-keyed sleeve and driver  
assembly 2-30, 2-37, 2-42  
reinstalling 3-18  
removing 3-17  
sleeve and key release cam  
assembly 2-13  
sleeve and key release cam  
assembly, non-IC 2-13

solenoid  
part numbers for 2-44, 2-46  
reinstalling 3-19  
removing 3-19  
reversing for function  
conversion 3-20

solenoid spring  
part numbers for 2-44, 2-46

spanner wrench  
part number for 3-2  
using 3-3 to 3-4

spring drive plate  
part number and drawing for 2-12 to 2-18, 2-20 to 2-25, 2-27 to 2-41  
part numbers for 2-44, 2-46  
reinstalling 3-17  
removing 3-16

spring loading tool 3-2, 3-13

strike plate locating pin 2-59 to 2-60

support, technical 1-4

**T**

T chassis  
function conversion for 2-48  
function description for 2-4

part numbers and drawings for 2-24

technical documentation package 1-3

technical support 1-4

throw member 2-33, 2-56

throw member support ring 2-56

thrust plate  
part number and drawing for 2-12 to 2-42  
part numbers for 2-44, 2-46  
reinstalling 3-14  
removing 3-12

trim  
non-standard stikes 2-50

troubleshooting questions 3-25

turn blade assembly for Z function 2-30, 2-37, 2-42

**W**

W chassis  
function conversion for 2-48  
function description for 2-6  
part numbers and drawings for 2-25

wire protector cap  
part numbers for 2-44, 2-46

**X**

XD chassis  
function conversion for 2-49  
function description for 2-9  
part numbers and drawings for 2-38

XR chassis  
function conversion for 2-49  
function description for 2-9  
part numbers and drawings for 2-39

**Y**

Y chassis  
function conversion for 2-48  
function description for 2-7  
part numbers and drawings for 2-26

YD chassis  
function conversion for 2-49  
function description for 2-9  
part numbers and drawings for 2-40

YR chassis  
function conversion for 2-49  
function description for 2-9

**Z**

Z chassis  
function conversion for 2-49  
function description for 2-10  
part numbers and drawings for 2-42