



# Installation Instructions

# Traditional Style Handed Door Closer Non Hold Open Models

## ASSA ABLOY

**CAUTION** An Incorrectly installed or improperly adjusted door closer can cause property damage or personal injury. These installation instructions should be followed to avoid the possibility of misapplication or misadjustment.

Adjustable  
(Sizes 2 thru 4)

**78B/D**

(Sizes 5 & 6)

**78E/F**

- Read these instructions **before** proceeding with the installation.
- Sex-bolts are required for mounting closer body or arm to non-reinforced hollow metal and wood or plastic-faced composite fire door.
- Make sure that the door opens the full angle desired and latches without binding action or interference.
- Select the type of installation from Figure 1 below.  
 Note: For special applications, a separate door and frame preparation template is packed with these instructions. Use this instruction sheet for installation sequence and closer adjustments only.
- Check hand of door, see Figure 1 below. Hand of door closer must be the same as hand of door. Door closer is handed, but can be easily reversed. SEE PAGE 4 FOR INSTRUCTIONS FOR REVERSING HAND OF CLOSER.

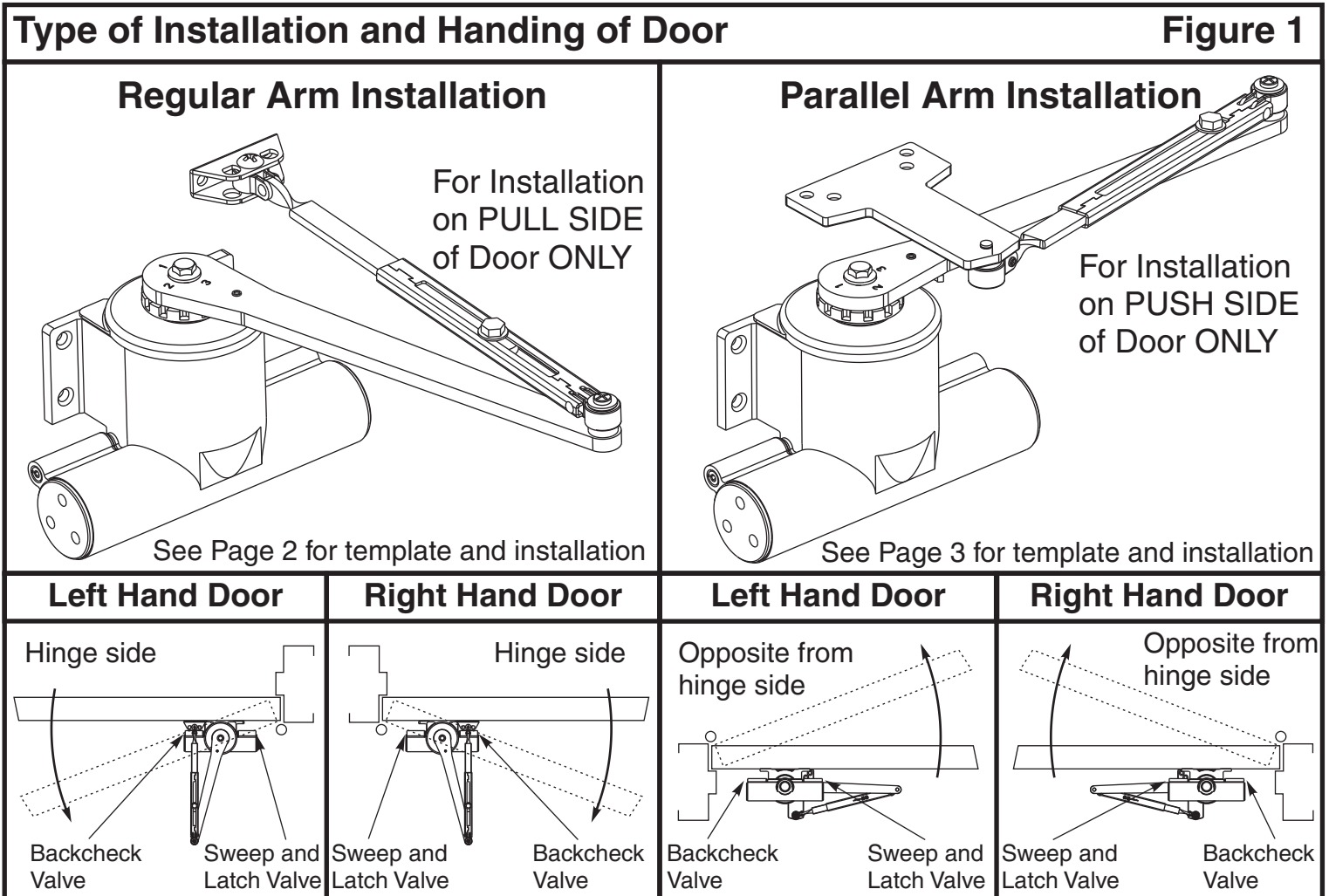

# 78 Series Non Hold Open Door Closers — Regular Arm



ASSA ABLOY

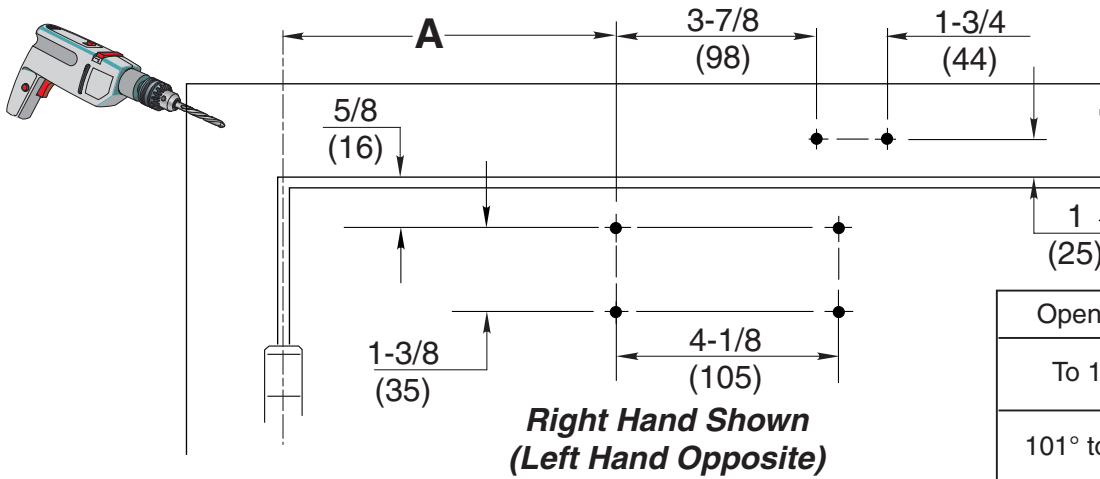

- Do not scale drawing.
- Dimensions shown in inches (millimeters)

Opening	Dimension "A"	
To 100°	8-1/8 (206)	Inches (mm)
101° to 135°	6-1/8 (155)	

1. Using the template above, select the angle of opening desired. Locate and mark the 4 holes on the door for the door closer body and the 2 holes on the frame for the arm shoe.
2. Prepare the door and frame for fasteners using the information from "Preparation for Fasteners" chart below.
3. Install closer body to door and the connecting rod / shoe assembly to the frame as shown.

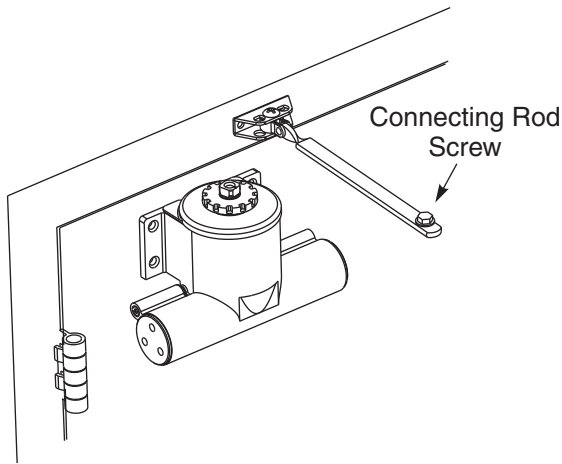

5. Remove screw from connecting rod. Open door slightly and assemble connecting rod into tubular slide. Close door. Adjust secondary arm assembly so that the main arm is perpendicular (90°) to face of door. Tighten screw securely.
6. **Closing Tension** - Place wrench (packed with door closer) on ratchet as shown. Swing wrench away from hinge to wind spring between 3 to 10 notches, engage dog in ratchet. Increase or decrease spring power to suit conditions.  
**CAUTION** - Overwound spring (more than 10 notches) will cause spring breakage.

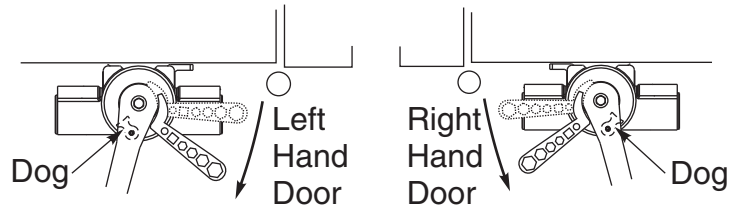

4. Following the main arm indexing illustrations as shown, place main arm assembly onto the closer pinion shaft. Install and tighten main arm screw with 1/2 in. wrench.

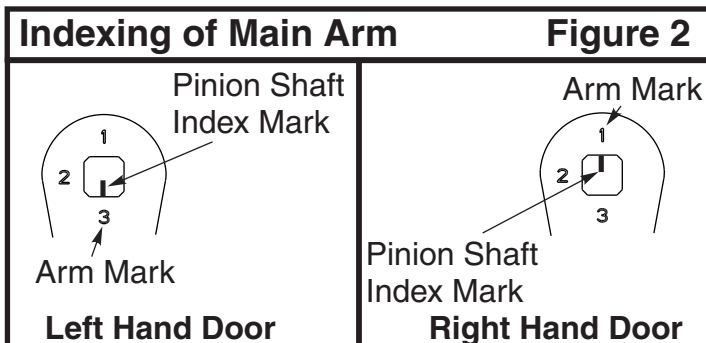

Preparation for Fasteners			
	Fasteners	Door or Frame	Drill-Sizes
<b>Standard</b>	Self-Drilling Screw	Aluminum or Metal	No drill required
		Wood (see Note)	3/16" (4.30 mm) (Pilot hole required)
	1/4" - 20 machine screw	Metal	Drill: #7 (0.201" dia.) Tap: 1/4" - 20
<b>Optional</b>	Sleeve nuts and bolts	Hollow Metal	9/32" (7 mm) through; 3/8" (9.5 mm) door face opposite to closer
		Aluminum or Wood	3/8" (9.5 mm) through
	Through-bolts and grommet-nuts	All	9/32" (7 mm); 3/8" (9.5 mm) dia. x 3/8" (9.5 mm) deep on door opposite to closer

Note: Wood doors/frames  
Pilot hole must be drilled when using self-drilling screws.

ASSA ABLOY, the global leader in door opening solutions

# 78 Series Non Hold Open Door Closers — Parallel Arm



ASSA ABLOY

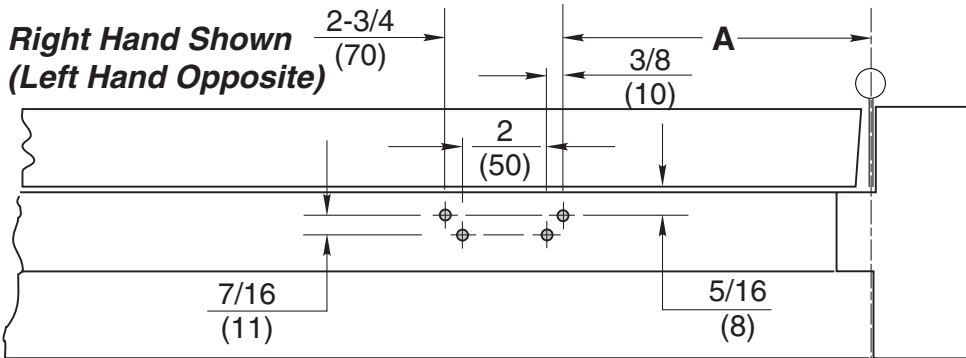

Door Opening	A	B
To 130°	7-3/4 (197)	8-1/2 (216)
130° to 180°	5-3/4 (149)	6-1/2 (165)

- Do not scale drawing
- Dimensions shown in inches (mm)

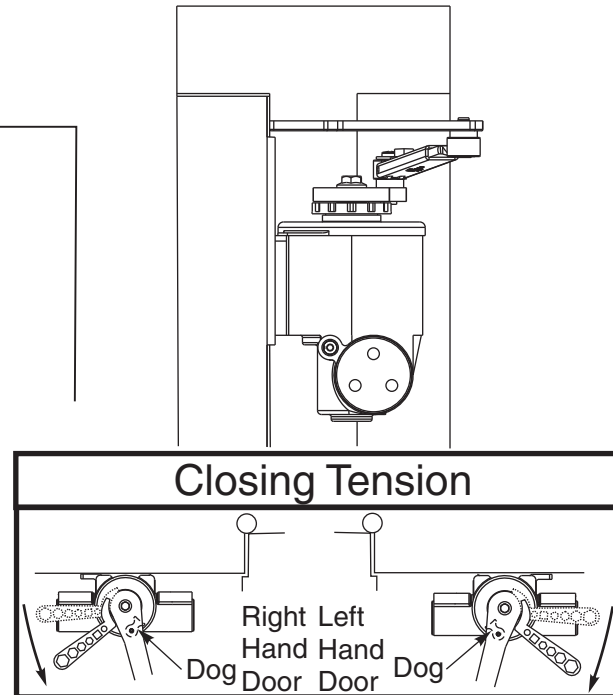
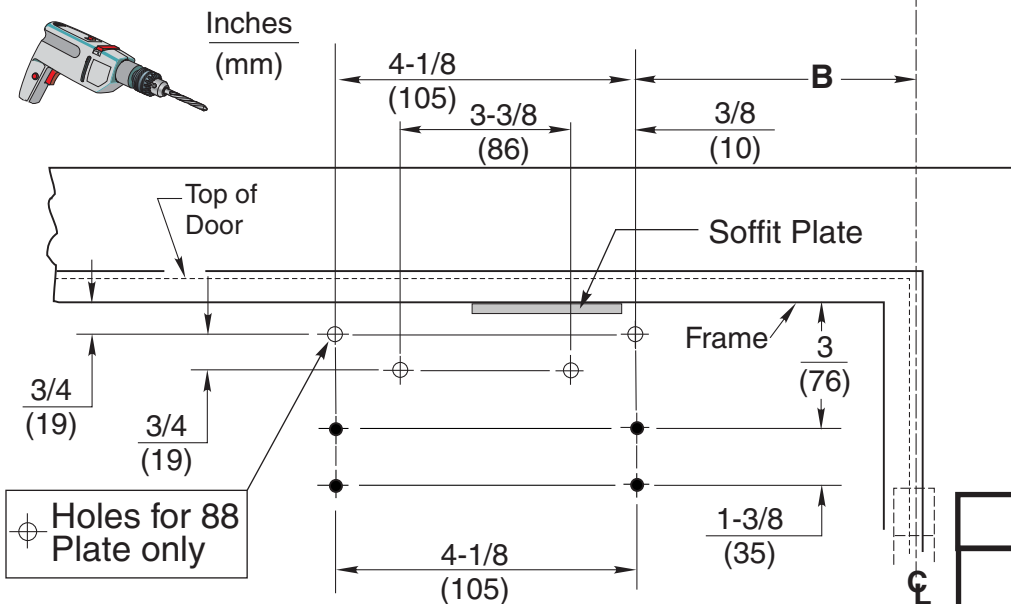

1. Using the template above, select the angle of opening desired. Locate and mark 4 holes on the door for either the closer body or #88 drop plate and the 4 holes on the frame for #1618 soffit plate.
2. Prepare the door and frame for fasteners using the information from "Preparation for Fasteners" chart on page 2.
3. Install closer body to door. If 88 drop plate is used, mount it first, then fasten the closer to the drop plate. Fasten soffit plate to frame soffit with 4 mounting screws.

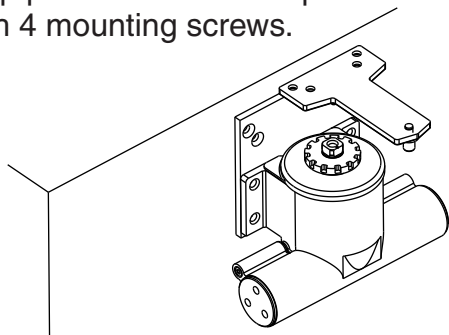

4. Following the main arm indexing illustrations as shown at right, place main arm assembly onto the closer pinion shaft. Install and tighten main arm screw with 1/2 in. wrench.

5. Remove screw from connecting rod. Open door slightly and assembly connecting rod into tubular slide. Close door. Adjust secondary arm assembly so that the main arm is approximately parallel with face of door. Tighten screw securely.
6. **Closing Tension** - Place wrench (packed with door closer) on ratchet as shown. Swing wrench toward hinge to wind spring between 3 to 10 notches, engage dog in ratchet. Increase or decrease spring power to suit conditions. **CAUTION** - Overwound spring (more than 10 notches) will cause spring breakage.

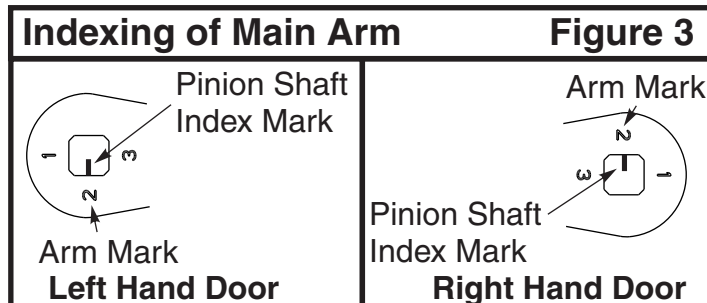

# 78 Series Adjustments Page

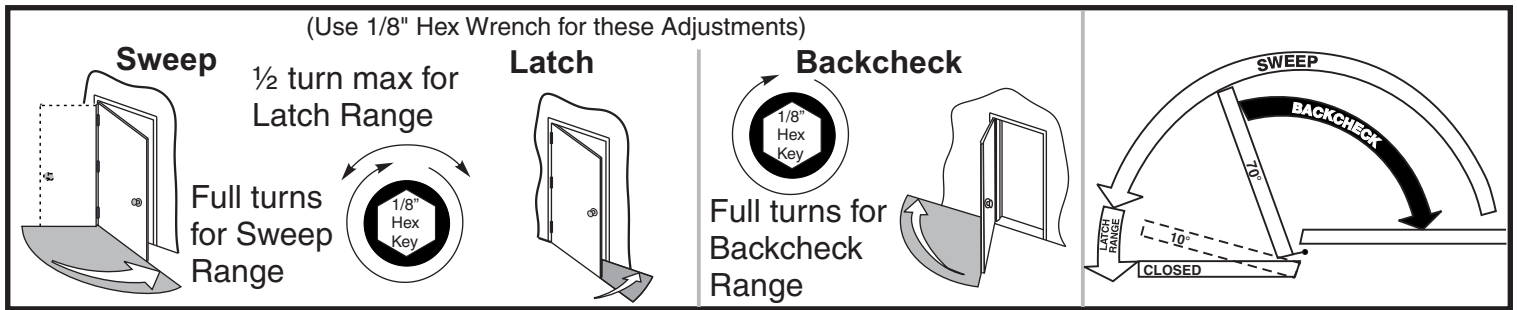

## Regular Arm Closer Adjustment:

**Closing Speed:** Controlled by the regulating valve on the end of the closer **closest** to the hinge.

**Sweep Speed:** Controls the door's speed in the sweep speed range, shown above. Full 360° **clockwise** turns **decreases** the sweep speed. Full 360° **counter-clockwise** turns **increases** the sweep speed.

**Latch Speed:** Controls the door's speed in the latch range, shown above. A partial turn, up to a maximum of 1/2 turn (180°) in either direction determines the latch speed.

**Backcheck:** Controlled by the regulating valve on the end of the closer **farthest** from the hinge. Backcheck cushions or slows the door opening speed near the end of the opening cycle. Full 360° **clockwise** turns **increases** resistance to opening. Full 360° **counter-clockwise** turns **decreases** resistance to opening.

**Note:** If backcheck is encountered extremely early in the opening cycle, rotate the valve 1/2 turn (180°) to eliminate early opening resistance.

**Caution:** To avoid damage to closer, never fully close the backcheck regulating valve.

## Parallel Arm Closer Adjustment:

**Closing Speed:** Controlled by the regulating valve on the end of the closer **farthest** from the hinge.

**Sweep Speed:** Controls the door's speed in the sweep speed range, shown above. Full 360° **clockwise** turns **decreases** the sweep speed. Full 360° **counter-clockwise** turns **increases** the sweep speed.

**Latch Speed:** Controls the door's speed in the latch range, shown above. A partial turn, up to a maximum of 1/2 turn (180°) in either direction determines the latch speed.

**Backcheck:** Controlled by the regulating valve on the end of the closer **closest** to the hinge. Backcheck cushions or slows the door opening speed near the end of the opening cycle. Full 360° **clockwise** turns **increases** resistance to opening. Full 360° **counter-clockwise** turns **decreases** resistance to opening.

**Note:** If backcheck is encountered extremely early in the opening cycle, rotate the valve 1/2 turn (180°) to eliminate early opening resistance.

**Caution:** To avoid damage to closer, never fully close the backcheck regulating valve.

## To Reverse Closer Hand:

1. Remove main arm screw, arm assembly, ratchet, and top cover.
2. Lift out spring using screwdriver wedged between coils (see figure at right).
3. Reverse spring and re-assemble to required hand (see figure at right).
4. Rotate shaft to required hand (see figure at right).
5. Replace cover and insert ratchet, lining up slot with inner hook on spring.

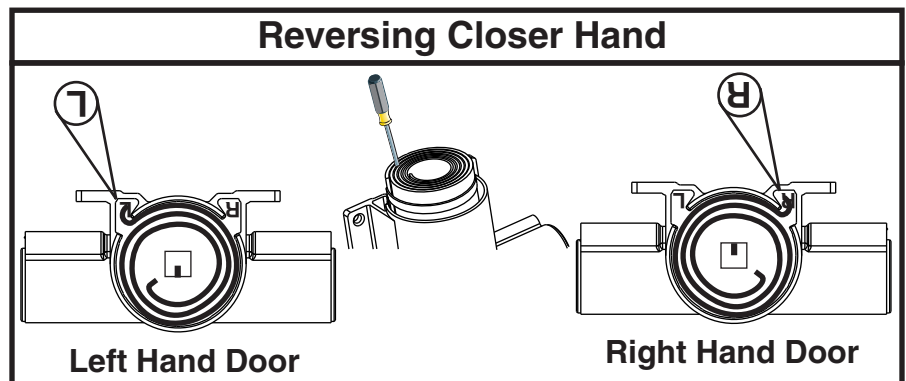

**Norton**  
ASSA ABLOY

3000 Highway 74 East • Monroe, NC 28112  
Tel: (877)-974-2255 • Fax: (800)-338-0965  
[www.nortondoorsolutions.com](http://www.nortondoorsolutions.com)