

INSTALLATION INSTRUCTIONS

NON-HOLD OPEN ARM

! Incorrect installation or adjustment could cause damage or injury. Read and follow instructions carefully.

Power size 1 thru 4

Option A – Regular Arm Installation

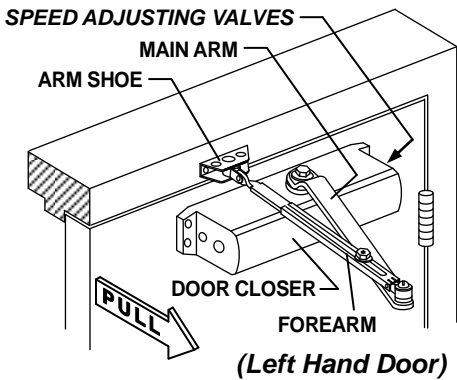
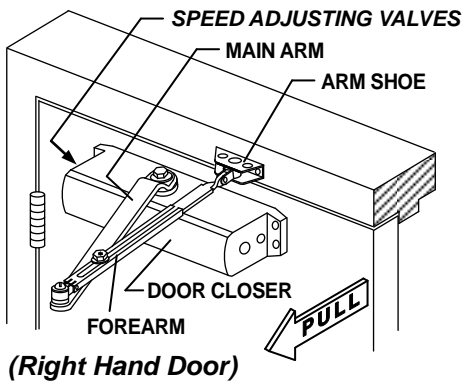
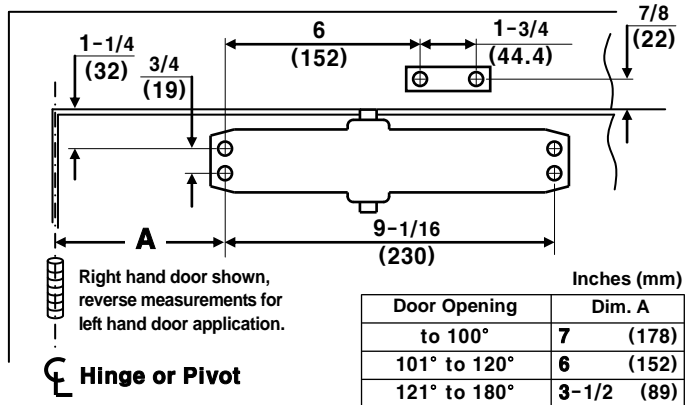

Diagram for Option A



Option A instructions: 1. Using the measurements from diagram A, mark screw hole center locations. Mark four (4) hole locations on door for door closer and two (2) hole locations on frame for arm shoe. 2. Drill pilot holes in door and frame, drill 7/32" (5.5mm) diameter holes for wood screws or drill and tap #7 (.201" diameter) for 1/4-20 machine screws. 3. Install adjustable forearm/arm shoe to frame using screws (a) or (b). 4. Mount closer on door using screws (c) or (d). **SPEED ADJUSTING VALVES MUST BE POSITIONED TOWARD HINGE SIDE.** 5. Install main arm to top pinion shaft, perpendicular to door. Secure tightly with arm screw/washer (e). 6. Adjust length of forearm so it is perpendicular to frame when assembled to preloaded main arm. Secure forearm to main arm with screw/washer (f). 7. Adjust closing speed, see page 2 for reference. 8. Snap pinion cap over shaft at bottom of closer or install (optional) cover with small screw (j).

Option B – Top Jamb Installation

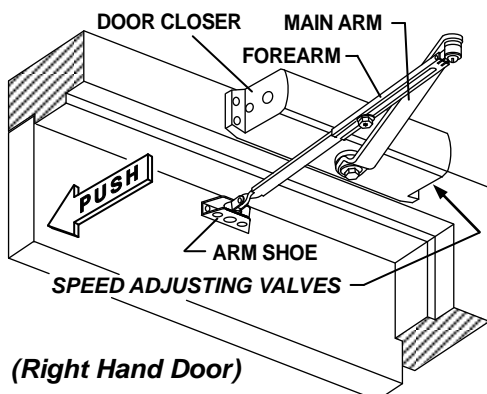
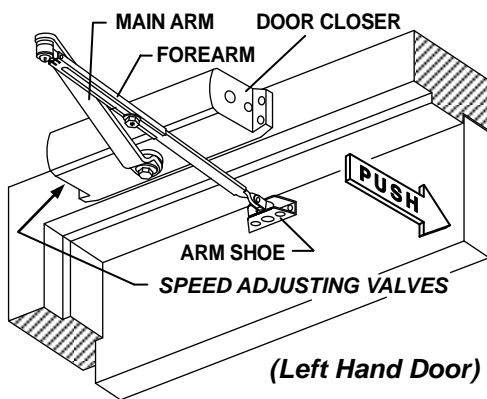
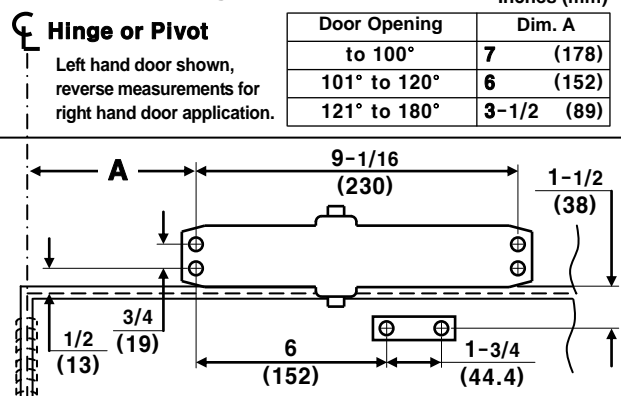
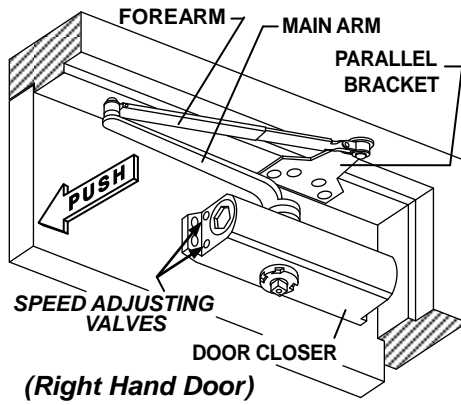
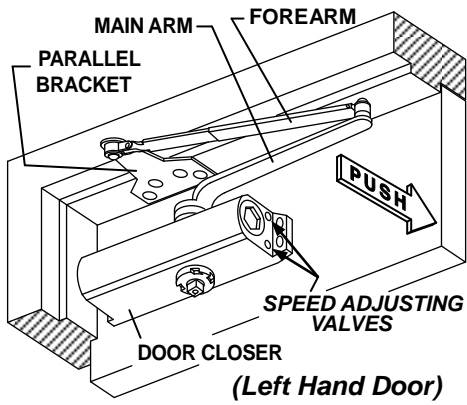

Diagram for Option B



Option B instructions: 1. Using the measurements from diagram B, mark screw hole center locations. Mark four (4) hole locations on frame for door closer and two (2) hole locations on door for arm shoe. 2. Drill pilot holes in door and frame, drill 7/32" (5.5mm) diameter holes for wood screws or drill and tap #7 (.201" diameter) for 1/4-20 machine screws. 3. Install adjustable forearm/arm shoe to door using screws (a) or (b). 4. Mount closer on frame using screws (c) or (d). **SPEED ADJUSTING VALVES MUST BE POSITIONED TOWARD HINGE SIDE.** 5. Install main arm to bottom pinion shaft, perpendicular to door. Secure tightly with arm screw/washer (e). 6. Adjust length of forearm so it is perpendicular to door when assembled to preloaded main arm. Secure forearm to main arm with screw/washer (f). 7. Adjust closing speed, see page 2 for reference. 8. Snap pinion cap over shaft at bottom of closer or install (optional) cover with small screw (j).

Option C - Parallel Arm Installation



Components

Screw Pack

- (a) Self-tapping x2
- (b) Machine x2
- (c) Self-tapping x4
- (d) Machine x4
- (e) x1
- (f) x1

Standard Pinion Cap



P-Bracket

- (g) Self-tapping x4
- (h) Machine x4
- (i) x1

Cover (Optional)

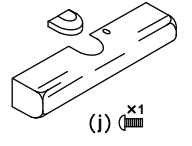
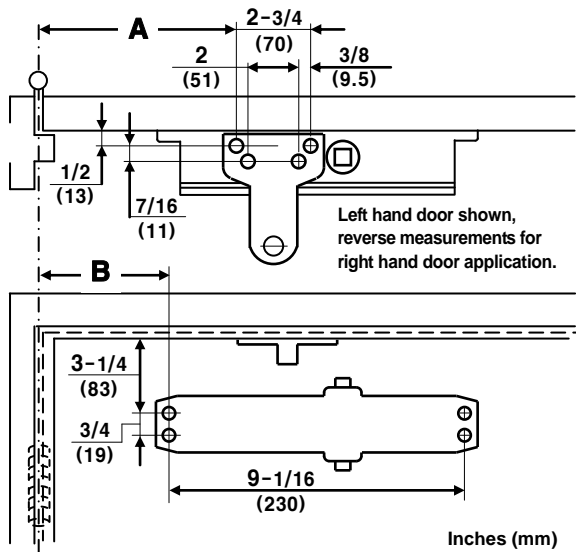

Diagram for Option C



Option C instructions:

- Using the measurements from diagram C, mark screw hole center locations. Mark four (4) hole locations on frame for door closer and four (4) hole locations on inside frame to mount parallel bracket.
- Drill pilot holes in door and frame, drill 7/32" (5.5mm) diameter holes for wood screws or drill and tap #7 (.201" diameter) for 1/4-20 machine screws.
- Install Parallel bracket to frame using screws (g) or (h).
- Mount closer on door using screws (c) or (d). **SPEED ADJUSTING VALVES MUST BE POSITIONED AWAY FROM HINGE SIDE.**
- Place main arm on closer pinion shaft. Index main arm - mark "L" or "R" with pinion flat as shown in Figure 1. Secure tightly with screw/washer (e).
- Remove arm shoe from forearm (see figure 2). Install Parallel bracket to end of forearm using the screw (i).
- With door closed, adjust length of forearm so that the tip of the main arm is approximately 1" (25mm) away from being parallel with door, when connected to the forearm. Secure with screw/washer (f).
- Adjust closing speed, see below.
- Snap pinion cap over shaft at bottom of closer or install (optional) cover with small screw (j).

Door Opening	Dim. A	Dim. B
To 100°	9-1/4 (235)	7-5/8 (194)
101° to 130°	7-3/4 (197)	6-1/8 (156)
131° to 180°	5-3/4 (146)	4-1/8 (105)

Figure 1

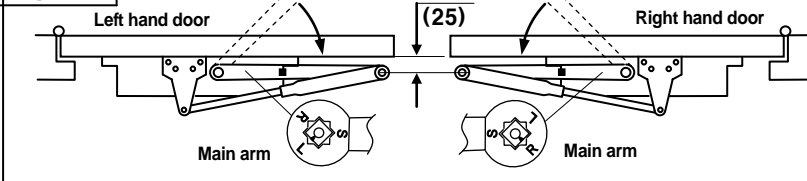
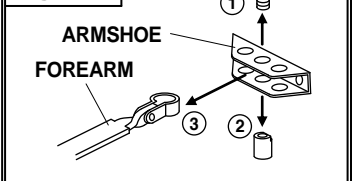

Figure 2



Hinge or Pivot

Left hand door shown, reverse measurements for right hand door application.

DOOR CLOSER ADJUSTMENT

CLOCKWISE FOR POSITIVE NUMBERS (+)



COUNTERCLOCKWISE FOR NEGATIVE NUMBERS (-)

Use 4mm Hex Wrench For this Adjustment

Power Adjusting Screw

INCREASE
DECREASE

CAUTION!! Do not turn speed adjusting valves more than two (2) full turns counter-clockwise. Do not back valves out of closer or a leak will result.

POWER ADJUSTMENT CHART

DOOR CLOSER SIZE	FULL TURNS OF POWER ADJUSTING SCREW	APPLICABLE DOOR LEAF WIDTH		APPLICABLE DOOR WEIGHT
		INTERIOR	EXTERIOR (SWING OUT)	
BF	-	5 lb-f		-
1	- 14	32" (0.81m)	28" (0.71m)	33~66 LBS (15~30 Kg)
2	- 10	36" (0.91m)	32" (0.81m)	66~99 LBS (30~45 Kg)
3	0 (PRESET)	42" (1.07m)	36" (0.91m)	99~143 LBS (45~65 Kg)
4	+ 6	48" (1.22m)	42" (1.07m)	143~187 LBS (65~85 Kg)

BACK CHECK Adjusting Valve

LATCH Adjusting Valve

SWEEP Adjusting Valve

SLOWER
FASTER

INCREASE
DECREASE



CLOSING CYCLE

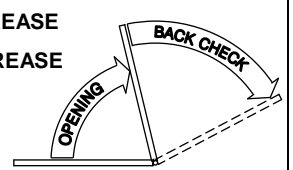

OPENING CYCLE



The closing force is adjustable from a size 1 to size 4, as outlined in ANSI Standard A156.4. When these series of door closers are installed and adjusted to conform to ADA reduced opening force requirements (5 lbs. max.) for Interior doors, they may not have adequate closing force to reliably close and latch door. Power adjustments charted on this page are recommended where possible, to ensure proper door control.



By law the Americans with Disabilities Act (ADA) may require that door closer installation comply with accessibility guidelines.