



ROTON INSTRUCTION SHEET
ROTON MODEL: 500-048

HAGER Companies - 139 Victor Street - St. Louis, MO 63104 1 (800)-325-9995

PART NO: 75005048

REVISION 021510

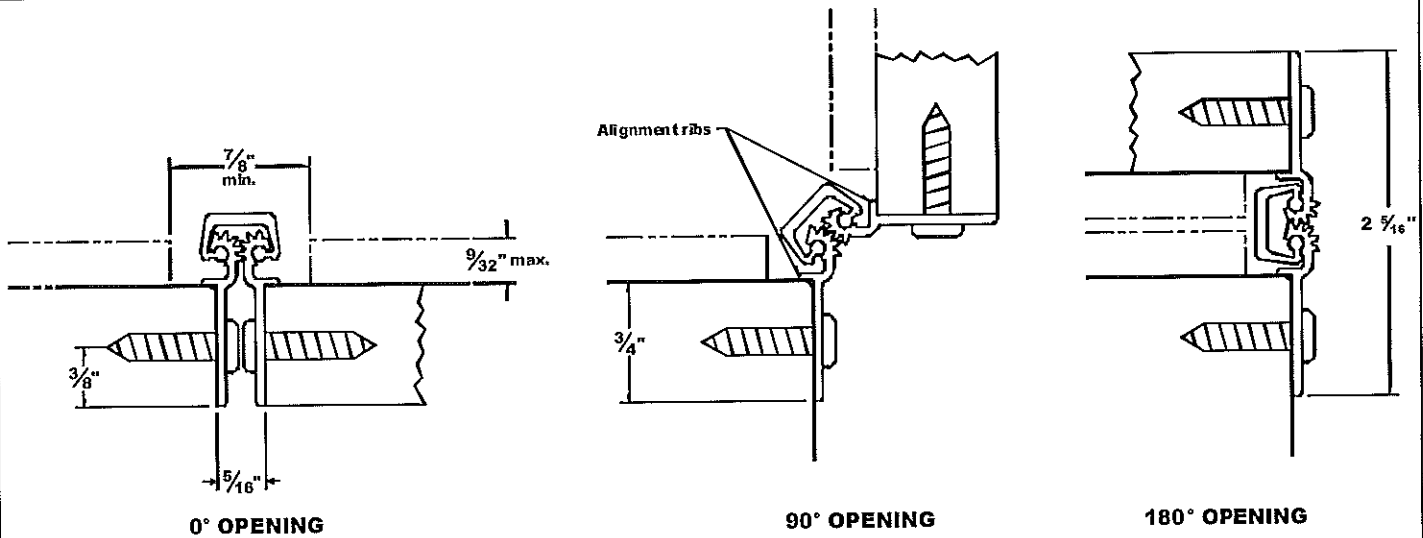

ROTON Model 500-048 is an Aluminum Continuous Geared Concealed Leaf Hinge. Minimum clearance required between the hinge edge of the door and the frame is 5/16" (7.9mm). The maximum allowable trim thickness is 9/32" (7.1mm) to maintain clearance when the hinge is in its fully open position of 180°.

Hinge Length

The 500-Series Hinges are supplied in four standard lengths. See chart. If the hinge must be trimmed shorter, determine the desired finished length and mark. Be careful not to cut within 1/2" of a bearing or screw hole. The excess length may be removed all from one end or by cutting equal amounts from both ends.

Actual Hinge Length	Number of Fasteners (Door Leaf / Frame Leaf)
24" (610mm)	6 / 6
36" (914mm)	9 / 9
48" (1219mm)	12 / 12
72" (1829mm)	18 / 18

Installation Procedure

Mounting Surface Preparation

1. With the hinge open, place the frame leaf against the mounting surface making certain that the alignment rib is flush against the face of the mounting surface along its entire length. Center the hinge within the opening. Mark and center punch the screw hole locations. *Accurate location is important for proper hinge installation.*
2. For wood and metal, drill pilot holes using a 1/8" (3.2mm) bit. For fiberglass, drill pilot holes using a 9/64" (3.6mm) bit. *Do not attach the hinge at this time.*

Door Preparation

1. With the hinge open, place the door leaf against the edge of the door making certain that the alignment rib is flush against the face of the door along its entire length. Center the hinge on the door. Mark and center punch the screw hole locations. *Accurate location is important for proper hinge installation.*
2. For wood and metal doors, drill pilot holes using a 1/8" (3.2mm) bit. For fiberglass doors, drill pilot holes using a 9/64" (3.6mm) bit. Attach the hinge to the door using the #8 truss head screws provided.

Hanging the Door

1. Position the door (with hinge attached) at 90° to the mounting surface. Attach the hinge using the #8 truss head screws provided.
2. Make a gentle trial swing. Carefully check the door for proper swing and clearance.

Adjusting the Door

1. If lateral adjustment is required because of excessive or uneven mounting clearance, adjust by loosening or removing the screws of the frame leaf and shimming where needed.
 - a) An effective shimming material is 5/8" strips of cloth duct tape. Apply tape to the mounting surface underneath the hinge leaf in stepped layers to build up to the desired thickness.
 - b) In a similar manner, a thin continuous plastic or aluminum strip may be used between the mounting surface and the hinge leaf to adjust the entire door.
2. Retighten all screws. Make a gentle trial swing. Carefully check the door for proper swing and clearance.