

1 Description

BEA introduces its new 36 Inch stainless steel push plate line. These push plates are designed to mount directly on any flat wall surface. The faceplate is made of stainless steel for durability, and has concealed fasteners for aesthetics and to minimize vandalism.

The push plates may be hard wired to an automatic door operator, activation input device or connected to BEA's line of radio-controlled transmitters. The transmitter is located within the plastic end cap to maximize signal strength.

Wireless P/N: 10LPR36-900, 10LPR36-433, 10LPR36-300

Hard wired P/N: 10LPR36-HW

Not recommended for use in an environment where it will be directly exposed to water. For example, outdoor, not protected from direct rain.



2 Specifications

Switch Sub Assembly		Push Plate Assembly	
Contact Configuration	SPST N.O.	Base Material	6063 Aluminum
Switching Voltage	.1 to 50 VDC	Face Plate	304 Stainless Steel
Switching Capacity	1 Watt	Switch Actuator Material	Nylon 66
Switching Current	.005 to 100 ma DC	End cap Material	UL94 ABS
Operating Temperature	-32F (-35C) to 212F (100C)	Hardware	Stainless Steel

CAUTION: TO BE CONNECTED TO A CLASS 2, POWER LIMITED, POWER SOURCE ONLY.

BATTERY REPLACEMENT:

300 MHz - A23 12 volt

433 MHz - CR2032 3 volt

900 MHz - CR2032 3 volt

3 Precautions



- Shut off all power going to header before attempting any wiring procedures.
- Maintain a clean & safe environment when working in public areas.
- Constantly be aware of pedestrian traffic around the door area.
- Always stop pedestrian traffic through the doorway when performing tests that may result in unexpected reactions by the door.
- ESD (electrostatic discharge): Circuit boards are vulnerable to damage by electrostatic discharge. Before handling any board ensure you dissipate your body's ESD charge.
- Always check placement of all wiring before powering up to ensure that moving door parts will not catch any wires and cause damage to equipment.
- Ensure compliance with all applicable safety standards and/or building codes (i.e. ANSI A156.10, 156.19) upon completion of installation.
- DO NOT attempt any internal repair of the components. All repairs and/or component replacements must be performed by BEA, Inc. Unauthorized disassembly or repair:
 1. May jeopardize personal safety and may expose one to the risk of electrical shock.
 2. May adversely affect the safe and reliable performance of the product resulting in a voided warranty.

4 Installation

1 MOUNTING LOCATION

CAUTION: PRIOR TO MOUNTING THE PLATE, ENSURE THE TWO (2) IN-TRANSIT LOCKING SCREWS ARE REMOVED FROM THE BACK OF THE PLATE. THESE SCREWS ARE NOT REQUIRED FOR INSTALLATION.

CAUTION: MOUNTING THE PLATE ON AN UNEVEN SURFACE WILL CAUSE THE SWITCHING MECHANISM TO HOLD THE CIRCUIT CLOSED AT ALL TIMES.

Determine appropriate location on the wall. Follow the appropriate steps below for the version that will be installed. If installing a hardwire version, it will be necessary to (following the steps below) install a junction box flush with the wall. The junction box and installation needs to be in accordance with the National Electric Code (NEC) or Local Codes. Use appropriate wall anchors for the wall type.

2 HARD WIRED VERSION

Install an appropriate junction box flush with the mounting surface approximately 3 inches centered below top edge of the plate assembly. Remove top screw caps, end cap screws and end cap. Make necessary electrical connections ensuring to keep excess wire(s) inside the junction box. Install appropriate anchor thru top mounting hole. To avoid activation issues, do not push excess wire(s) into the plate assembly during re-assembly.

Route cable to flush mounted junction box. Ensure to use appropriate cable to activation input device.

Top Mounting Hole

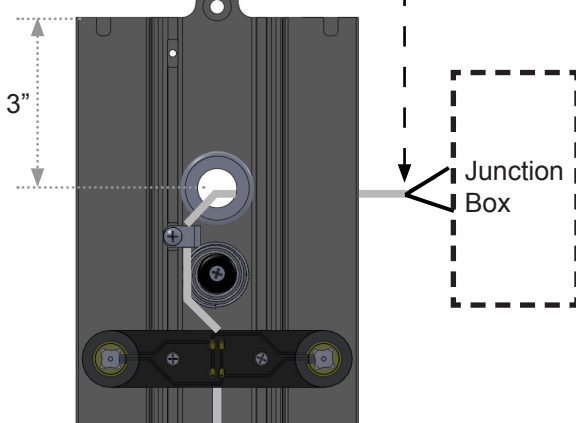

Plate assembly and end cap removed to show cable routing.

WIRELESS VERSION

CAUTION: DO NOT PULL ON THE CABLE ATTACHED TO THE TOP END CAP.

Remove Top Screw Caps, End Cap Screws and End Cap. Allow Top End Cap assembly to hang by the cable during the following steps. Install appropriate anchor thru top mounting hole. To avoid activation issues, do not push excess wire(s) into the plate assembly during re-assembly.

NOTE: To complete the wireless setup procedure, review the respective wireless transmitter user guide.

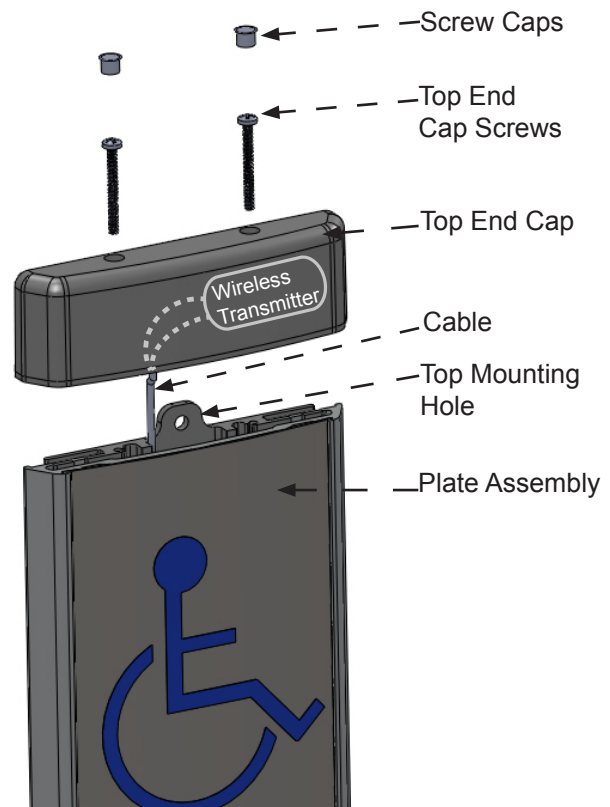

4 Installation continued

3 BOTTOM PLATE ASSEMBLY AND ALIGNMENT

To expose the bottom mounting hole, slide the front plate upwards a few inches. Insert one of the top end cap screws in the threaded hole on the bottom of the base plate to hold the front plate up.

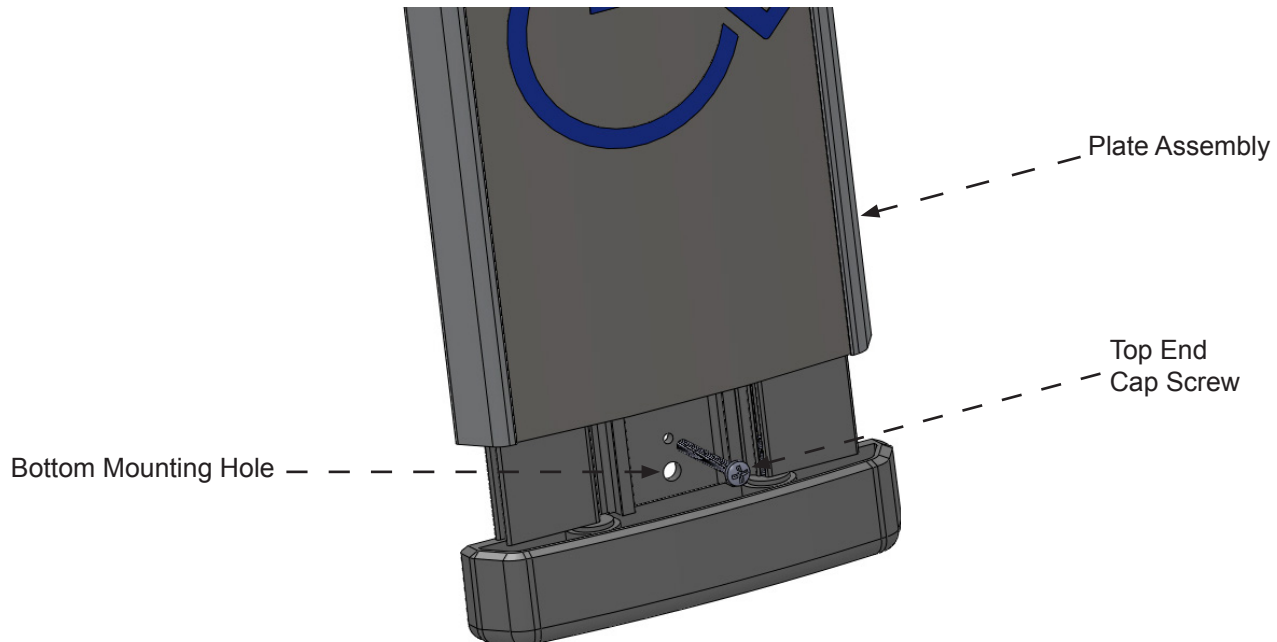

With the bottom mounting hole now exposed, plumb the plate assembly and install the bottom mounting screw. Remove top end cap screw from base while supporting the front plate. Slide the front plate back down. Replace top end cap with the provided screws and insert push-in plastic screw caps.

5 Cleaning

The push plates are constructed with durable stainless steel and painted with scuff-resistant coatings. To clean the plates, use only a damp, non-abrasive cloth. Regular cleaning with harsh solvents or abrasive materials may cause deterioration of the paint coating. Ensure the user is aware of this procedure.

6 Company Contact

ANSI / AAADM Compliance  *American Association of Automatic Door Manufacturers*

Upon completion of the installation or service work, at a minimum, perform a daily safety check in accordance with the minimum inspection guidelines provided by AAADM. Provide each equipment owner with an owner's manual that includes a daily safety checklist and contains, at a minimum, the information recommended by AAADM. Offer an information session with the equipment owner explaining how to perform daily inspections and point out the location of power/operation switches to disable the equipment if a compliance issue is noted. The equipment should be inspected annually in accordance with the minimum inspection guidelines. A safety check that includes, at a minimum, the items listed on the safety information label must be performed during each service call. If you are not an AAADM certified inspector, BEA strongly recommends you have an AAADM certified inspector perform an AAADM inspection and place a valid inspection sticker below the safety information label prior to putting the equipment into operation.

7 Company Contact



Do not leave problems unresolved. If a satisfactory solution cannot be achieved after troubleshooting a problem, please call BEA, Inc. If you must wait for the following workday to call BEA, leave the door inoperable until satisfactory repairs can be made. Never sacrifice the safe operation of the automatic door or gate for an incomplete solution.

Our Service Technicians can be called 24 hours a day, 7 days a week. For more information visit www.beasensors.com.

Phone: 1-800-523-2462		Fax: 1-888-523-2462	
After Normal Business Hours			
West / Mexico 1-888-419-2564	Central 1-800-407-4545	AK, MI, WI, TX, Canada 1-866-836-1863	East 1-866-249-7937