

SPECIFICATIONS

THE DYNALOCK MODEL #5400 POWER SUPPLY FEATURES:

- 1 AMP CONTINUOUS OUTPUT @ 12VDC
- BUILT-IN BATTERY CHARGING CIRCUIT
- 4 AMP/HOUR RECHARGEABLE BATTERY
- 16 VAC PLUG-IN TRANSFORMER
- FUSED BATTERY CHARGING CIRCUIT
- AUTO-SWITCHOVER TO BATTERY UPON FAILURE OF THE AC INPUT

CHARGER MODULE SPECIFICATIONS:

DIMENSIONS - 3.6"L X 2.1"W X 1.5"H
OUTPUT CAPACITY - 12VDC @ 1AMP
BATTERY FUSE - 5AMP / 250VAC

TRANSFORMER SPECIFICATIONS:

DIMENSIONS - 3.5"H X 2.2"W X 2"D
INPUT - 120VAC / 60HZ @ 0.23 AMPS
OUTPUT - 16VAC / 20VA CLASS 2
 PLUGS INTO STANDARD DUPLEX OUTLET. FOR INDOOR USE ONLY.

BATTERY SPECIFICATIONS:

DIMENSIONS - 4"H X 3.5"W X 3"D
SIZE RATING - 12VDC / 4AH
TYPE - SEALED LEAD-ACID

WIRING INFORMATION

MODEL #5400

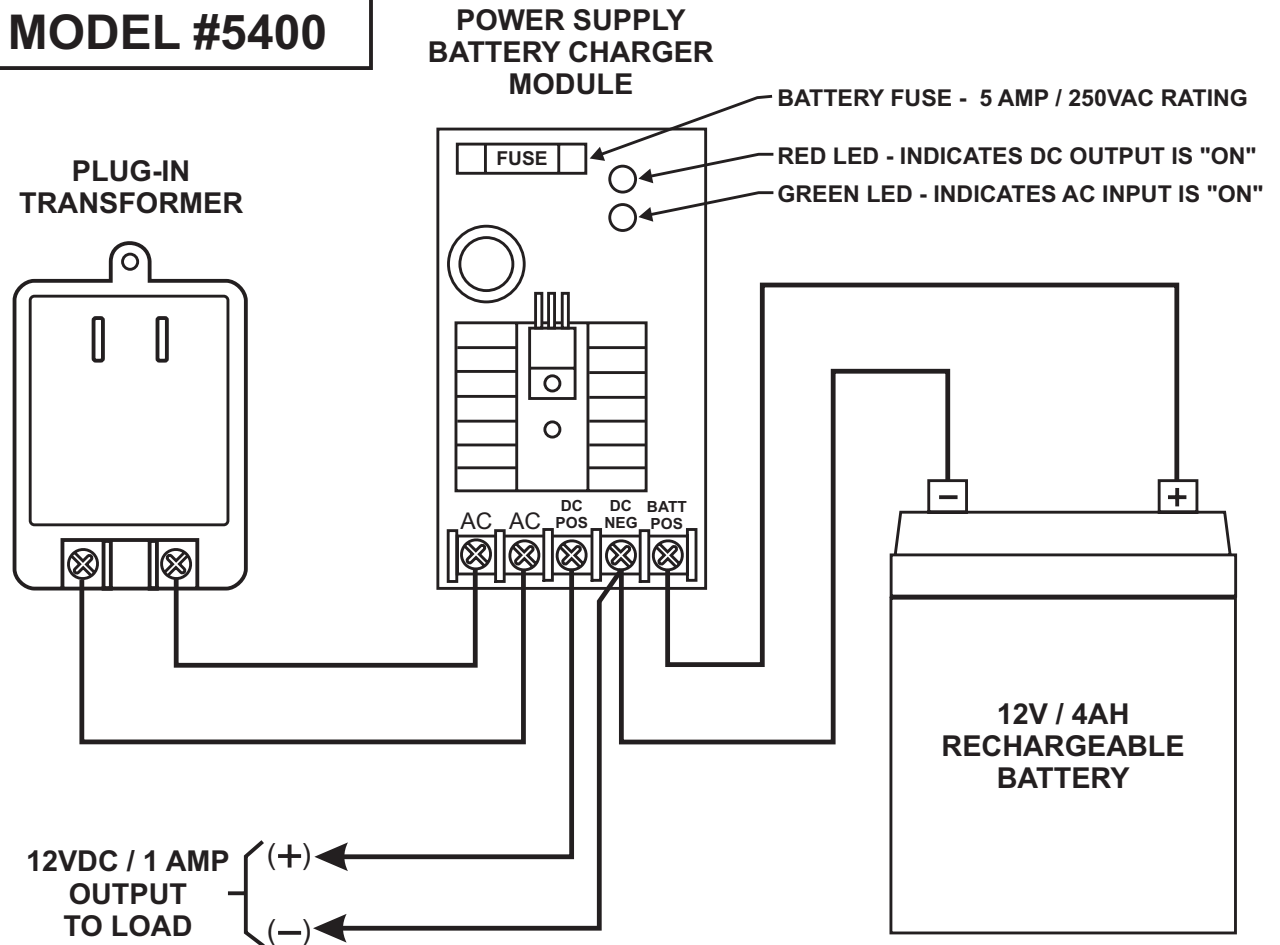

INSTALLATION PROCEDURE:

- 1.) CONNECT THE 5400 POWER SUPPLY COMPONENTS AS SHOWN ABOVE.
- 2.) CONNECT THE DC OUTPUT TO DYNALOCK LOCKING DEVICE(S) OR OTHER COMPATIBLE SYSTEM LOAD NOT EXCEEDING 1 AMP @ 12VDC.
- 3.) FOR CONVENIENCE, THE CHARGER MODULE CIRCUIT BOARD MAY BE MOUNTED TO THE TOP OF THE BATTERY USING THE DOUBLE-STICK TAPE PROVIDED.

DynaLock Corp.
 705 Emmett Street
 Forestville, CT 06010

TITLE
 MODEL #5400 BATTERY BACK-UP POWER SUPPLY
 SPECIFICATIONS & WIRING INFORMATION

DRN. BY JAS
DATE 07/01/98
SCALE ———

DWG. NO.
500256