

# 4820 Series



The 4820 Auto Equalizer™ is LCN's pneumatically powered multi-door solution. This low-energy automatic operator provides easy access for people with disabilities, or the elderly. Designed primarily for manual opening applications that occasionally require automatic opening.

## Features

<b>Certifications</b>	ADA, 100 Hour Salt Spray, Meets BAA - Buy American Act	<b>Cover</b>	Metal Cover (MC)
<b>Body construction</b>	<ul style="list-style-type: none"> <li>Cast iron body</li> <li>Full complement bearing</li> <li>1 1/2" diameter piston</li> <li>3/4" diameter double heat treated pinion journal</li> </ul>	<b>Fasteners</b>	Wood and Machine Screws (WMS)
<b>Fluid</b>	All weather fluid	<b>Mounting</b>	Top jamb (push side)
<b>Handing</b>	Non-handed	<b>Arms</b>	<ul style="list-style-type: none"> <li>Regular Arm (REGARM), standard</li> <li>Long Arm (LONG), optional</li> </ul>
<b>Size</b>	Adjustable spring size 2-5	<b>Finishes/colors/ powder coat</b>	<ul style="list-style-type: none"> <li>689 Aluminum</li> <li>690 Statuary Bronze</li> <li>691 Light Bronze</li> <li>693 Black</li> <li>695 Dark Bronze</li> <li>696 Brass</li> <li>Custom colors optional</li> </ul>
<b>Warranty</b>	2 years		<ul style="list-style-type: none"> <li>Optional SRI primer - powder coat only</li> <li>Optional plated finishes</li> </ul>

### Special templates

Customized installation templates or products may be available to solve non-standard applications. Contact LCN Product Support for assistance.

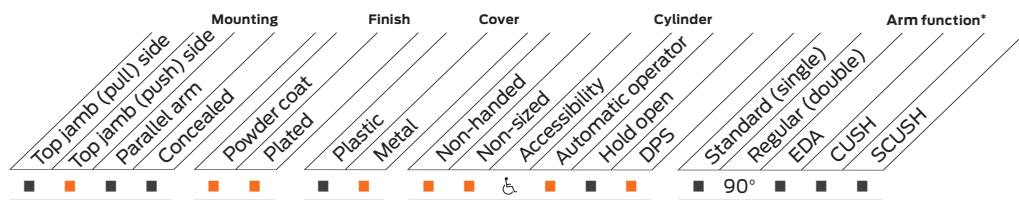

■ Available  
■ Not available

Meets ADA requirements (power mode).  
 \* See individual series for maximum manual opening.

## Mounting details

### Top jamb (push side) mounting

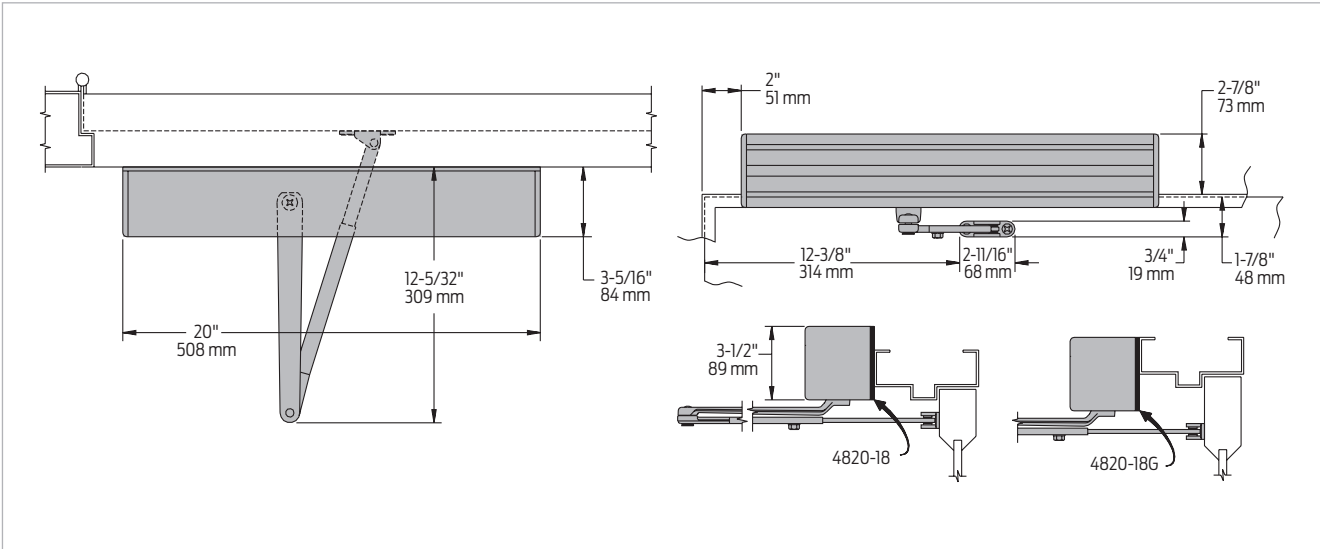

Butt hinges	Should not exceed 5" (127 mm) in width
Auxiliary stop	Recommended
Reveal	<ul style="list-style-type: none"> <li>4 1/2" (114 mm) allows up to 90° power opening and 100° manual opening</li> <li>8" (203 mm) allows up to 90° power opening and 100° manual opening with long arm where standard rod and shoe is replaced with optional long rod and shoe, 4820-79LR</li> </ul>
Top rail	<ul style="list-style-type: none"> <li>Minimum 1 3/4" (44 mm)</li> <li>Closer on 4820-18G plate requires 3" (76 mm) minimum</li> </ul>
Head frame	<ul style="list-style-type: none"> <li>Minimum 1 3/4" (44 mm)</li> <li>With flush ceiling use plate, 4820-18G substituted for standard plate</li> </ul>
System diagram	See pages 9-10 for typical system wiring, and pages 28-29 for electrical and pneumatic data for control boxes
Maximum opening	Templating allows 90° power opening and 100° manual opening
Options	Door Position Switch (DPS) kit that signals when the door has reached the open position

Notes:

- Requires control box with integral compressor or control box using auxiliary air supply
- See control box pages 27-29 and actuators and accessories, pages 100-117
- Guard rails/safety mats not required

## Accessories

### Cylinders



- 4822-3971  
Cast Iron Cylinder  
Assembly (CYL)**
- Non-handed
  - Standard



- 4822-3071  
Standard Cylinder with 18G  
mounting plate (CYL18G)**
- Non-handed
  - Includes; 4820-18 Mounting Plate or 4820-18G Mounting Plate (must specify)
  - Standard

### Covers

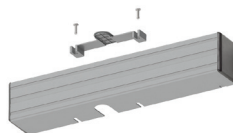

- 4820-72MC  
Metal Cover (MC)**
- Non-handed
  - With black end caps
  - Standard

### Arms



- 4820-3077  
Regular Arm (REGARM)**
- Non-handed
  - Standard



- 4820-3077L  
Long Arm (LONG)**
- Includes long rod and shoe, 4820-79LR for deep reveals
  - Optional

### Installation accessories



- 4820-18  
Plate**
- Requires minimum 1 3/4" (44 mm) minimum head frame and 2" (51 mm) top rail
  - Standard



- 4820-18G  
Plate**
- Requires minimum 1 3/4" (44 mm) minimum head frame and 2" (51 mm) top rail
  - Standard



- 4820-3377  
Door Position Switch Kit**
- Provides feedback when the door reaches the fully opened position
  - Specify RH or LH when ordering