

**INSTALLATION**  
Door and Frame Installation

**DIMENSIONS**  
Inches (Millimeters)

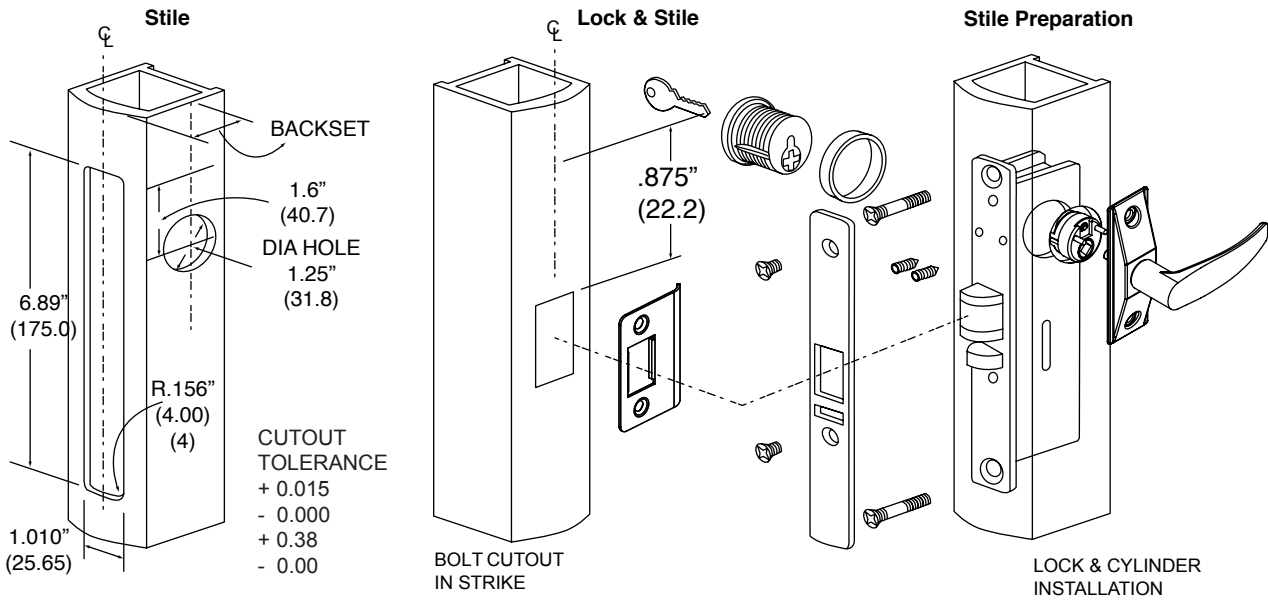

**DIMENSIONS**  
Inches (Millimeters)

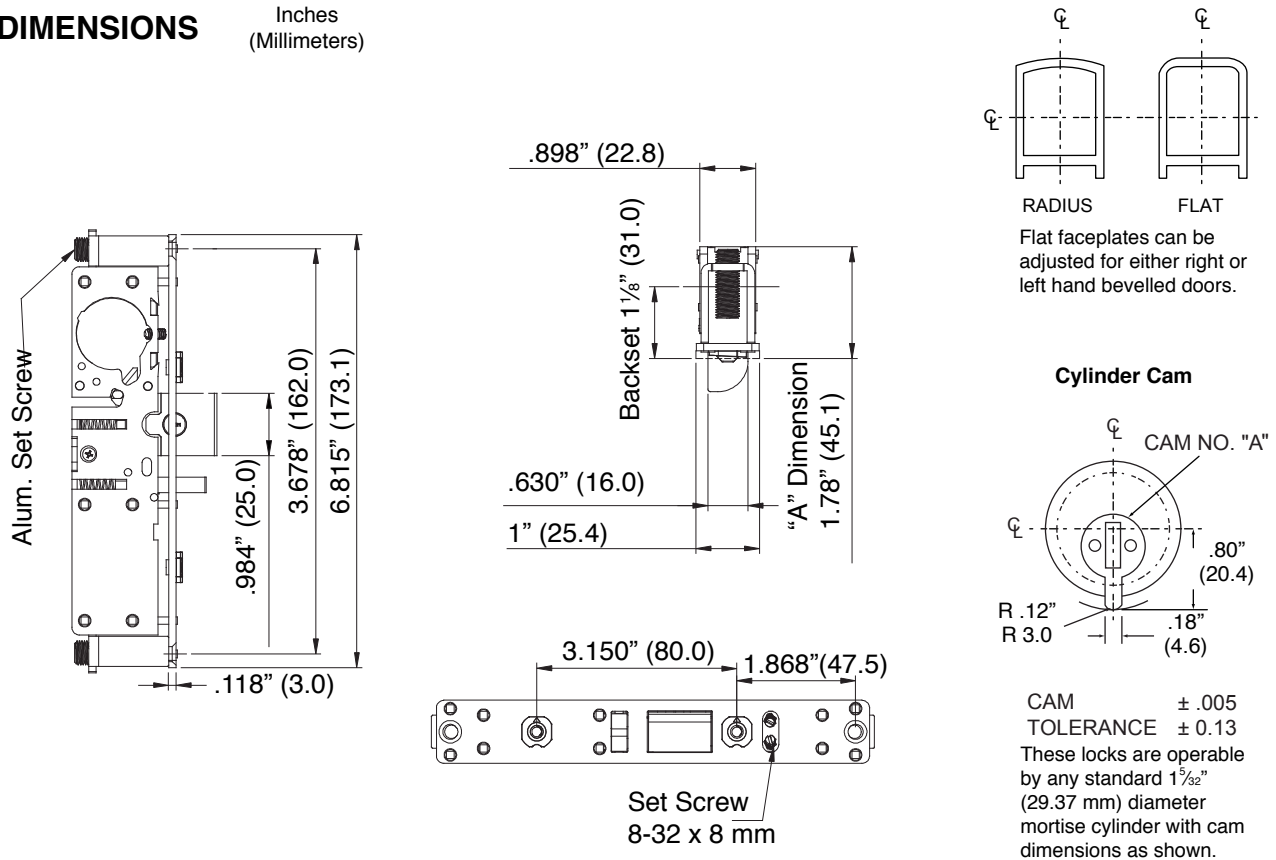

---

## CHANGING HANDS

1. Push in latch bolt until the screw can be seen through the latch case hole
2. Remove screw, rotate latch bolt to the other hand
3. Push in latch bolt until you see the counter sink hole on the latch bolt
4. Install screw

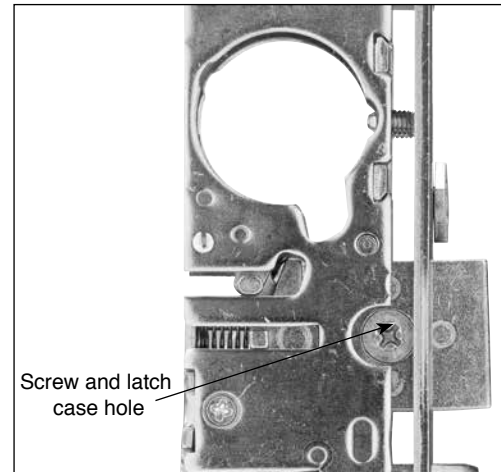

---

## BEVEL TAB ADJUSTMENT

The bevel tabs allow the flat faceplates to adjust to either left or right hand bevelled stiles. For radius faceplates point the arrows towards the latch bolt.

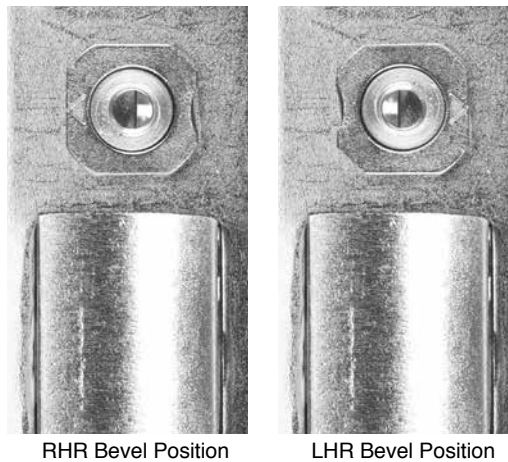

---

## DEPTH ADJUSTMENT

Measure the depth from the back of the stile to the inside wall of the door edge. Equate the distance from the face of the mounting plate to the end of depth adjusting tube spacers. Use a  $\frac{3}{16}$ " (4.76 mm) hex key to find tune depth. Hex key size is the same as the one included in the 459 series push pull paddles.

