

4110T Series



The 4110T is a Grade 1 push side, mounting track closer designed for interior high traffic applications. It features an optional track bumper assembly for additional cushioning in the opening swing of the door.

Features

Certifications	Grade 1 - ANSI A156.4, UL 10C, ADA, 100 hour salt spray, meets BAA - Buy American Act
Body construction	<ul style="list-style-type: none"> Cast iron body Full complement bearing 1 1/2" diameter piston 11/16" diameter double heat treated pinion journal
Fluid	All weather fluid
Handing	Handed
Size	Sized 1, 3, or 4
Warranty	30 years

Cover	<ul style="list-style-type: none"> Plastic Cover (PC), standard Metal Cover (MC), optional
Fasteners	Self reaming and tapping screws (SRT)
Mounting	Stop face (push side)
Arms	Standard arm and track with roller
Finishes/colors/ powder coat	<ul style="list-style-type: none"> 622 Matte black 689 Aluminum 690 Statuary bronze 691 Light bronze 693 Black 695 Dark bronze 696 Brass Custom colors optional
	<ul style="list-style-type: none"> Optional SRI primer - powder coat only Optional plated finishes

Special templates

Customized installation templates or products may be available to solve non-standard applications. Contact LCN Product Support for assistance.

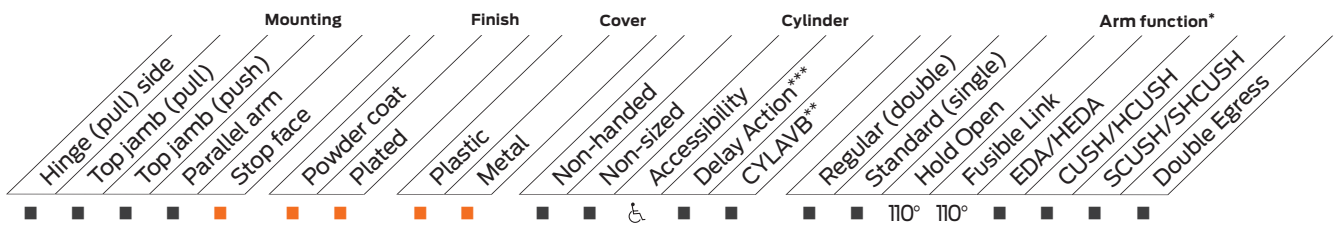

- Available
- Not available

♿ Closer available with less than 5.0 lbs. opening force on 36" door.
 * Maximum opening/hold open point with standard template.
 ** Advanced Variable Back Check.
 *** Delay feature incorporates standard 4040 cylinder (not XP).

Introduction
 Product selection guide
 4010/4010T Series
 4020/4020T Series
 4030/4030T Series
 4040XP/4040XPT Series
 4050A/4050AT Series
 4110/4110T Series
 4000T Series

Mounting details

Stop face (push) side mounting

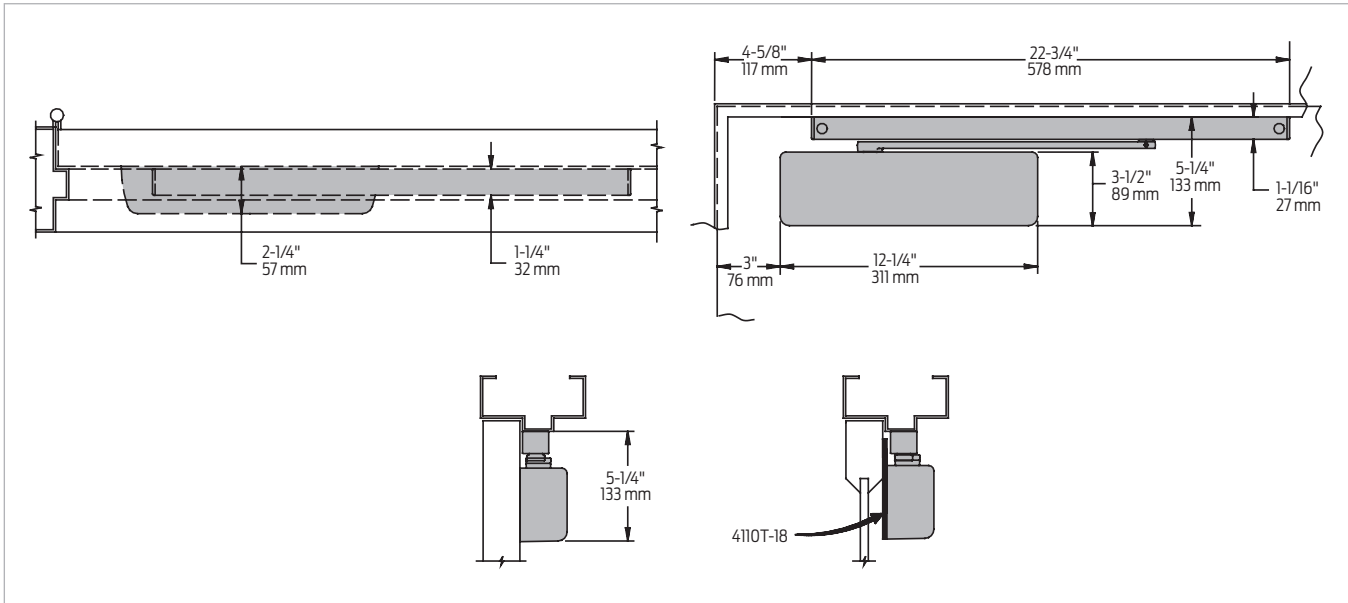

Butt hinges	Should not exceed 5" (127 mm) in width
Auxiliary stop	<ul style="list-style-type: none"> Recommended at hold open point or where a door cannot swing 110° Optional track bumper assembly assists back check in cushioning the opening swing of the door It is not intended to replace an auxiliary stop
Clearance	Projects 2 1/4" (57 mm) from face of door
Top rail	<ul style="list-style-type: none"> Less than 5 1/4" (133 mm) measured from the stop, requires plate, 4110T-18 Plate requires 2 1/4" (57 mm) minimum
Stop width	Minimum 1 1/4" (32 mm)
Maximum opening	<ul style="list-style-type: none"> Templating allows 110° with standard track arm, limited to 100° with optional bumper tracks Variable hold open angles with many options

Note: Consult factory for applications where door must swing 180°.

Accessories

Cylinders

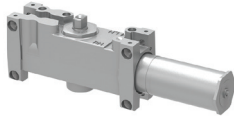

- 4111(3,4)T-3071
Cast iron cylinder
assembly (CYL)**
- Handed
 - Standard

Covers

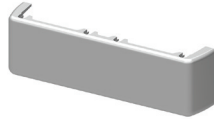

- 4110T-72
Plastic Cover (PC)**
- Non-handed
 - Standard

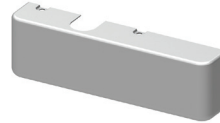

- 4110T-72MC
Metal Cover (MC)**
- Handed
 - Required for plated finishes and custom powder coat finishes
 - Optional

Arms



- 4110T-3077T
Standard Arm (STDTRKARM)**
- Handed
 - Roller not included with arm

Tracks



- 4110T-3038
Standard Track (STDTRK)**
- Non-handed
 - Non hold open
 - Will accept hold open clip and/or bumper assembly
 - Standard



- 4110T-3038B
Track with Bumper (BUMP)**
- Non-handed
 - Non hold-open
 - With bumper assembly installed
 - Will accept hold-open clip
 - Optional



- 4110T-3038H
Hold Open Track (H)**
- Non-handed
 - With hold open clip installed
 - Will accept bumper assembly
 - Optional



- 4110T-3038HB
Hold Open Track with Bumper (HBMP)**
- Non-handed
 - With hold open clip and bumper assembly installed
 - Optional

Installation accessories



- 4110T-18
Plate**
- Required where top rail, when measured from the stop, is less than 5 1/4" (133 mm)
 - Requires minimum 2 1/4" (57 mm) minimum top rail



- 4110T-169
Track bumper**
- Mounts in track to assist back check, not replace auxiliary stop
 - Limits maximum opening; consists of bumper, bumper post, and mounting screw

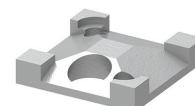

- 4110T-3054
Hold-open clip**
- Mounts in track to provide hold open function
 - Hold open point controlled by clip location
 - Consists of clip and mounting screws
 - Requires 4110T-3034H track roller



- 4110T-3034H
Track roller**
- Quiet, low friction roller assembly
 - Shoulder dimension "X" = 1/16" (2mm)
 - Spring-loaded hold-open mechanism



- 4110T-3034
Track roller**
- Quiet, low friction roller assembly
 - Shoulder dimension "X" = 1/16" (2 mm)