

INSTALLATION DESCRIPTION

The 3121B and 3121B2 Delay Egress Systems are 1500 pound holding force per leaf electromagnetic locks, electronically controlled to provide a 15 or 30 second delay in unlocking. The 3121B is one piece, for use on openings without a center mullion. The 3121B2 is two pieces, with a ribbon cable connecting the two, for use on openings with a center mullion. All models have a master/slave configuration, meaning both leaves lock, unlock, and alarm in tandem.

Both models require mechanical and electrical installation procedures as described herein. When completed, a simple adjustment procedure to set door movement will finalize the installation.

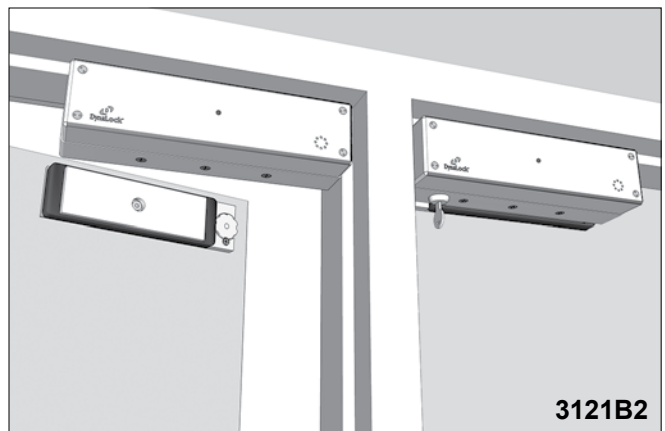
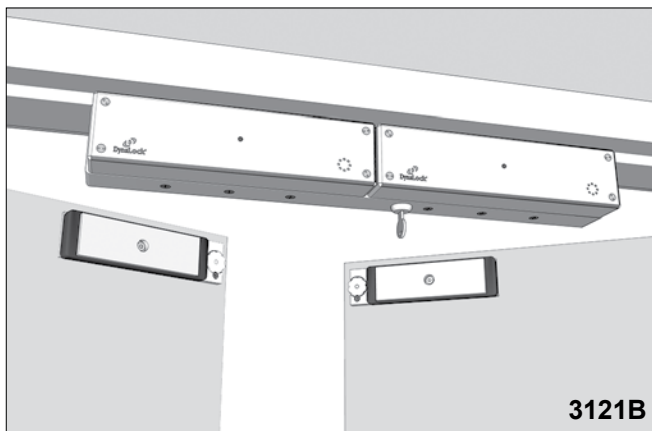

HANDLING

The electromagnetic lock and armatures are ruggedly constructed and designed to provide years of trouble-free service. Care must be taken during installation and use that the lock faces and armature faces are kept free of dirt, rust, paint, or any other obstruction which may interfere with the lock and armatures making good contact.

MECHANICAL INSTALLATION

Familiarize yourself with the door and frame conditions. Both models must mount rigidly to the underside of the door frame header. The 3121B should be centered on the frame. For the 3121B2, both locks should mount against the center mullion. The door mounted armatures are supplied with hardware that allows them to pivot slightly and pull away from the door as part of the delayed egress function.

NOTES: This lock does not change hands to match the hand of the door. Do not remove the coil assembly from the lock housing. For locks ordered with the DSM2 option, please verify that two magnets are installed inside each of the armature housings.

ELECTRICAL INSTALLATION

After mechanical installation is complete, the lock needs to be wired and adjusted. A continuous power source, 12 or 24 VDC or VAC is required. Once low voltage power is supplied the unit is fully operational. Delay egress systems also normally require fire panel tie-in. All other wiring is for selected options.

NOTE: Please see Egress Sensor Adjustment (page 8) before applying power.

TABLE OF CONTENTS

General Information.....	1
Bill Of Materials.....	2
Using The Template.....	3
Mounting The Armature Assembly.....	4
Mounting The Lock.....	5
Basic Set-Up.....	6
Basic Wiring.....	7
Egress Sensor Adjustment.....	8
Indicator Descriptions.....	9
Optional Set-Up.....	10
Option Wiring.....	11-12
Factory Wiring.....	13-14
Exploded Parts View.....	15
Exploded Parts Legend / Support.....	16

BILL OF MATERIALS

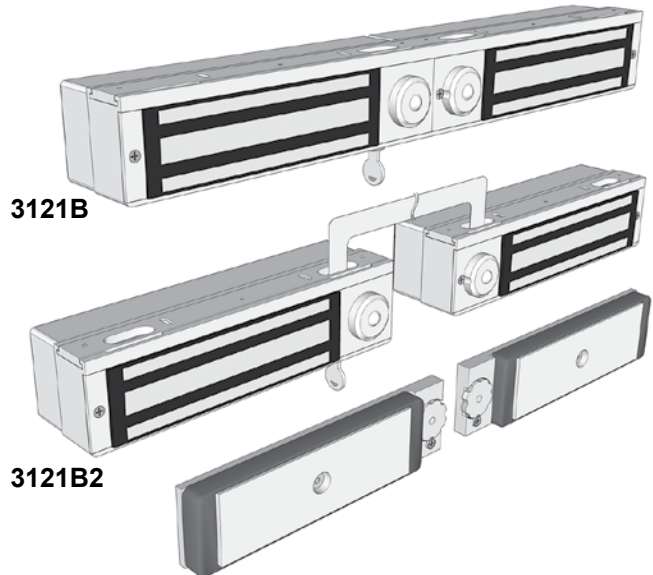

- (1) LOCK ASSEMBLY
- (2) ARMATURE
- (2) ARMATURE HOUSING
- (2) ARMATURE MOUNTING PLATE ASSEMBLY
- (2) HARDWARE KIT
- (2) DOOR SIGN - "15 SECONDS" *
- (1) TEMPLATE
- (1) INSTALLATION MANUAL

* "30 SECONDS" SIGNS AVAILABLE

REQUIRED TOOLS

- (1) Electric Drill
- (1) #2 Phillips Screwdriver
- (1) Soft Faced Mallet
- (1) Hammer
- (1) Center Punch
- (1) Pencil & Tape
- Drill Bits: 1/8", 5/16", 3/8", 9/16"

HARDWARE KIT CONTENTS - (2) Part #301325

<u>QTY.</u>	<u>ITEM</u>	<u>DESCRIPTION</u>
(5)	Fas-Trak Mounting Screws	#10 x 1" phillips pan head tek screw
(5)	Fas-Trak Mounting Screws	10-24 x 1/2" phillips pan head machine screw
(1)	Armature Mounting Screw	5/16-18 x 1" hex flat head machine screw, turned
(1)	Armature Spacer	3/8"D x 0.360"L
(1)	Armature Spring	Compression spring
(4)	Armature Mounting Plate Screws	#10 x 1" phillips flat head sheet metal screw
(4)	Armature Housing Mounting Screws	8-32 x 3/8" phillips machine screw
(1)	Anti-Tamper Cover Screwdriver	#6 spanner key
(1)	Fas-Trak Set Screw Wrench	1/8" ball head hex wrench
(1)	Armature Bolt Wrench	3/16" hex wrench
(1)	Thread Locking Compound Liquid	
(2)	Bypass/Reset Key	
(1)	Mini Screwdriver	

NOTE: For further parts clarification refer to the Exploded Parts View on page 15 or consult factory.

MOUNTING CONSIDERATIONS

Inspect the door frame and determine if an angle bracket, spacer or filler plate will be required for installation. The lock will require a 2-9/16" wide header stop for a suitable mounting surface.

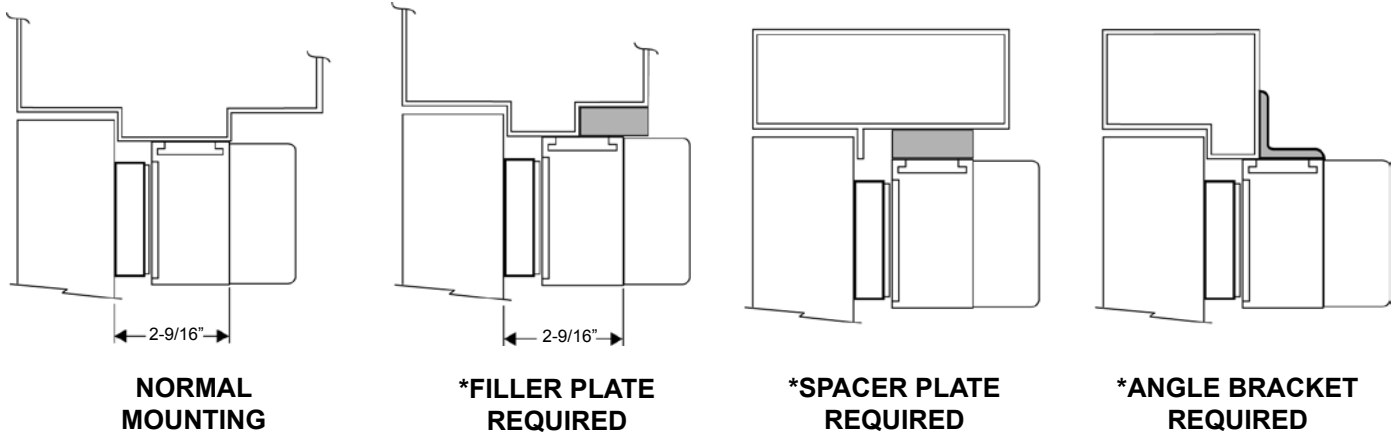

*These items are available from DynaLock.

USING THE TEMPLATE

1. Fold the template(s) on the dotted line to form a 90 degree angle. Scoring the template(s) with a straight edge and a screwdriver will make it fold easier.
2. **3121B:** With the doors in the closed and latched positions, place the template against the header and doors, centered on the frame. Tape in place.
3121B2: With the doors in the closed and latched positions, place the templates against the header and doors, with the edges against the center mullion. Be sure to use the correctly handed template for each door. Tape in place.
3. Transfer all hole locations to both the doors and header with a center punch, then remove the template(s) from the doors.
4. Referring to the template(s), drill four 1/8" dia. lock mounting holes and one or two 9/16" dia. wiring hole(s) in the top of the frame, at the transferred locations.
5. Drill the remaining transferred holes in the face of each door to accept the Armature Mounting Plate Assemblies:
 - a. Four 1/8" dia. mounting screw holes, 1" deep.
 - b. One 3/8" dia. armature screw clearance hole, 3/8" deep.
 - c. One 5/16" dia. adjustment wheel screw clearance hole, 1/4" deep.

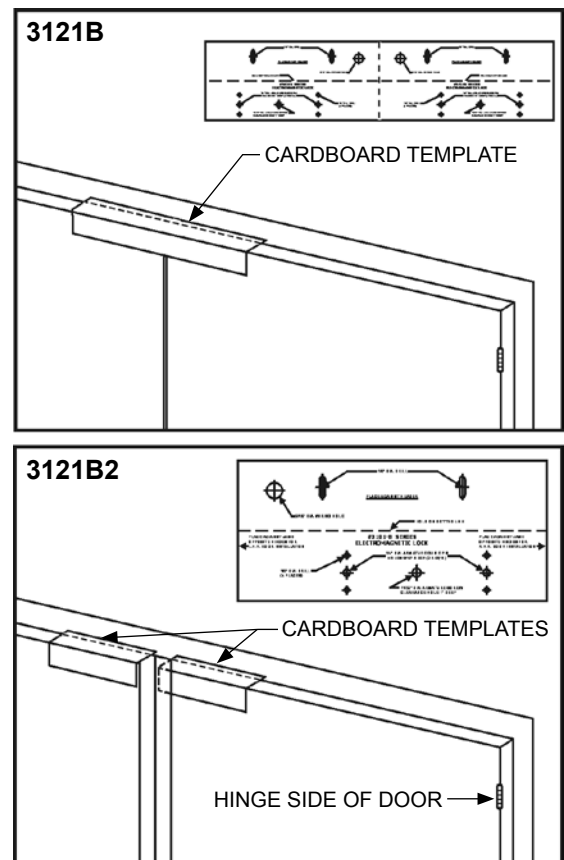

MOUNTING THE ARMATURE ASSEMBLIES

Using the four #10 x 1" flat head sheet metal screws attach the armature mounting plate to the door. Firmly tighten the screws with a #2 phillips screw driver.

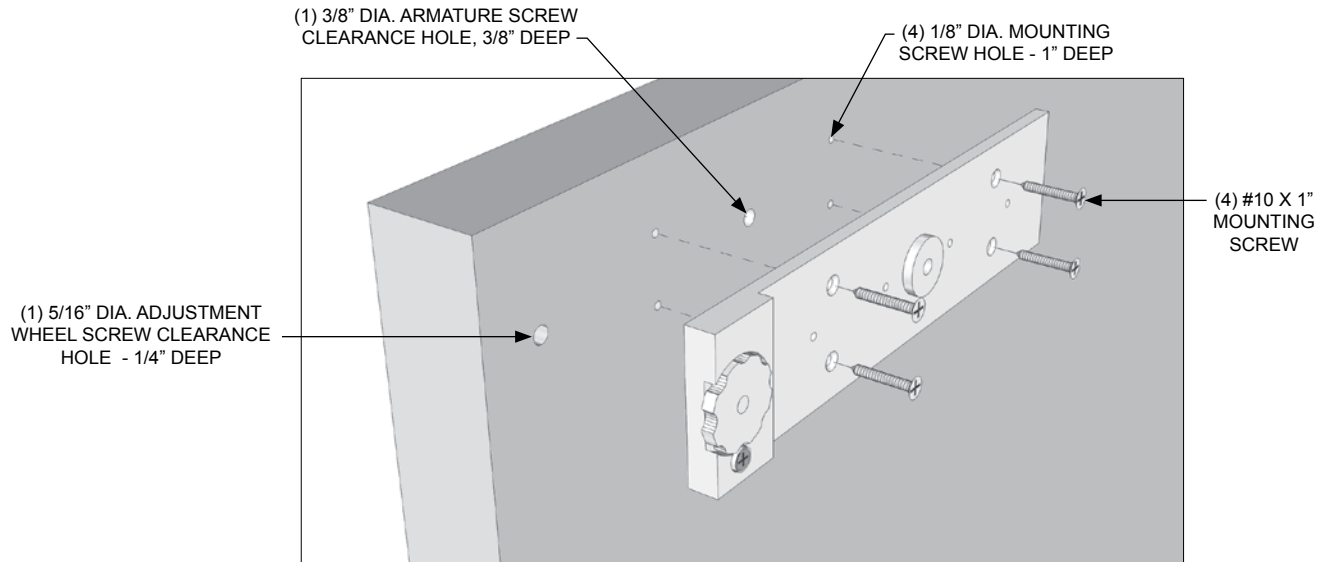

Attach the Armature to the Mounting Plate Assembly using the hardware supplied. Apply the supplied thread locking compound to the threads of the Armature Mounting Screw and firmly tighten with a 3/16" hex wrench. The head of the armature mounting screw must not project beyond the face of the armature. **Failure to properly secure the Armature to the door could result in serious injury or possible security breach.**

Check the installation by pushing in on a corner of the Armature - it should move. Although the mounting screw is tight the Armature should have approximately 1/4" of free play, under slight spring tension.

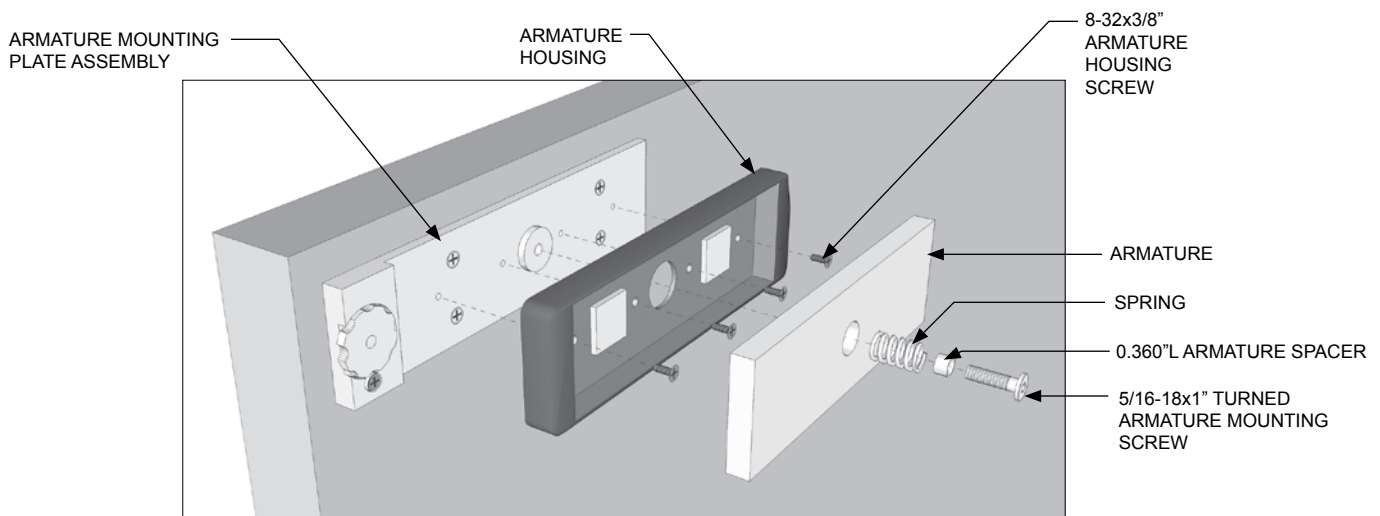

REPEAT FOR OTHER DOOR

MOUNTING THE LOCK

1. Before installation begins remove the rear Electronics Covers, End Covers and Sensor Cover Assemblies (see page 13-15 for parts locations). Carefully unplug the sensor harnesses from the circuit board connectors and detach the Sensor Cover Assemblies from the lock. For 3121B2, carefully remove the ribbon cable. In the upper inside corners of the lock housing(s) are located #1/4-28 set screws. Using the 1/8" ball head hex wrench loosen (**do not remove**) the set screws until the Fas-Trak Baseplate(s) is free (Fig. "C"). Remove the Fas-Trak(s).
2. Place the Fas-Trak(s) against the header with the slot counter bores visible and the tabs facing the doors (Fig. "A"). Attach the Fas-Trak(s) to the header at the slotted hole locations, with #10 x 1" tek screws or 10-24x1/2" machine screws. Tighten the screws just snug enough to allow for final adjustment.
3. Temporarily mount the lock(s) to the Fas-Trak(s) by offsetting the lock(s) 1-1/8" from the jamb (Fig. "C") and tipping the front of the lock(s) down engaging the rear flange of the Fas-Trak(s) (Fig. "B"). Rotate the lock(s) up allowing two tabs (one for 3121B2) to pass through the corresponding notch in the top of the lock housing. Slide the lock(s) into position. Close and latch the doors. Check that the armature and lock faces make full contact. If any adjustment is required gently tap the housing(s) with a soft mallet until full contact is achieved. Open the doors, remove the lock(s) from the Fas-Trak(s) and tighten the slot screws. Drive additional screws into the header using the Fas-Trak(s) as a physical template. Screw heads must not project above the Fas-Trak(s).
4. Any roughed-in wiring may be brought in at this time through the slotted wiring hole(s) (for 3121B2 include ribbon cable). Re-install the lock on the Fas-Trak(s). Firmly tighten the housing set screws with the 1/8" ball head hex wrench. Re-install the End Covers and Sensor Cover Assemblies. Carefully plug the Sensor harnesses back into the connectors on the circuit boards (see page 13&14). **If the lock wiring and set-up are not being done at this time, replace the Electronics Covers and see that these instructions (and ribbon cable for 3121B2) are left for the electrical installer.**

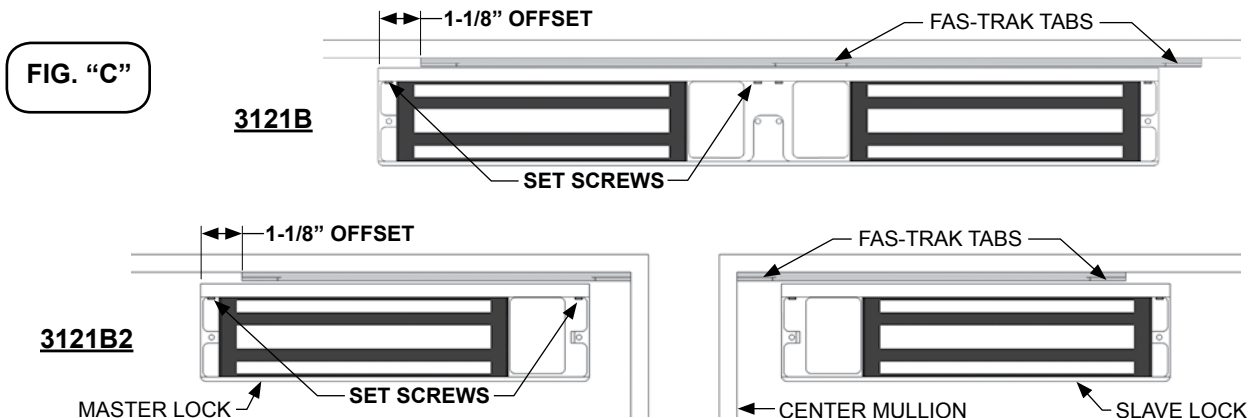
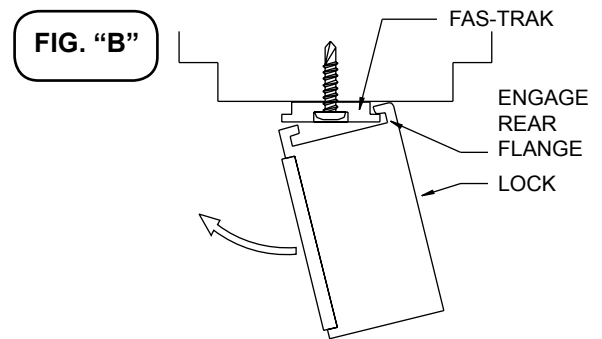
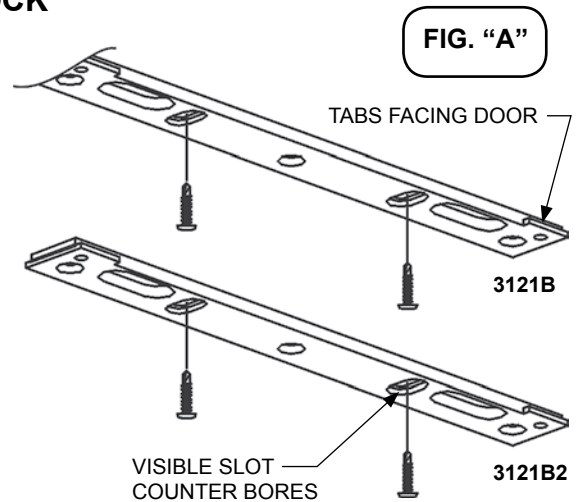

BASIC SET-UP

1. Remove the Electronics Cover from the Master Lock (right side) to expose the master circuit board assembly.

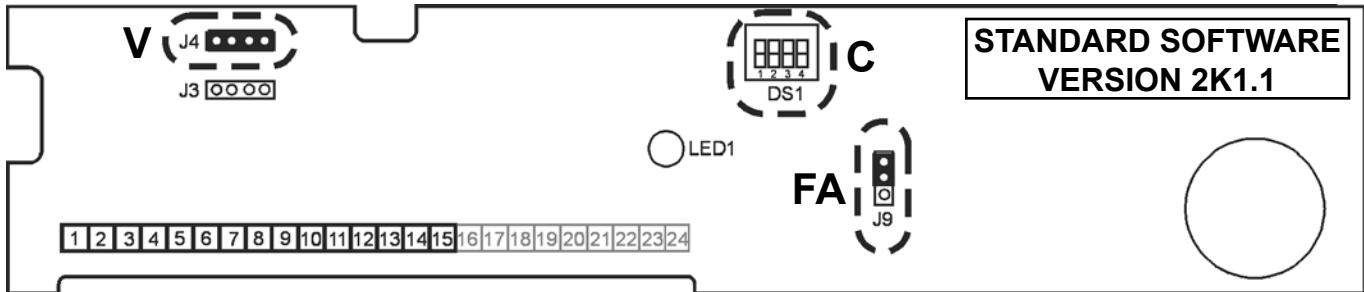

2. V - Voltage Selection

Check that the voltage selection jumper (J4) is properly set to match your input power. Note that all locks are factory set for 24 volts.

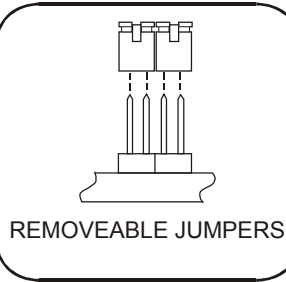

(Factory Setting)

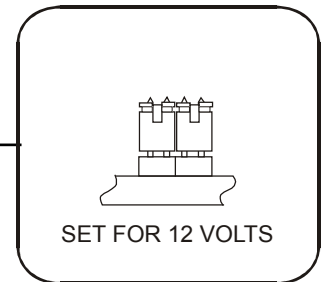
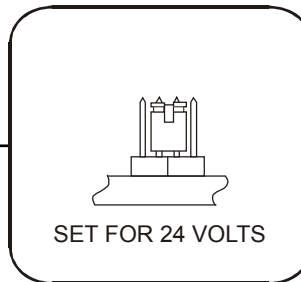

3. FA - Fire Alarm Control

Check that the fire alarm control jumper (J9) is properly set to match your fire panel input contacts. If fire panel tie-in is not required leave jumper at factory setting (N.O.).

(Factory Setting)

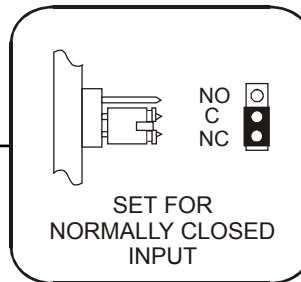
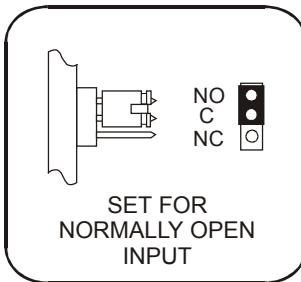

4. C - System Selector Switches

The selector switches (DS1) that control major system functions are factory set to the OFF position for basic lock operation. Switch 1 will be used during sensor adjustment (page 8). Switches 2, 3 and 4 are only used for options described on page 10.

(Factory Setting)

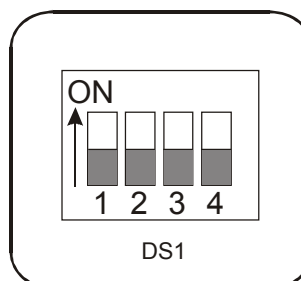

BASIC WIRING

Basic hook-up is shown below. For other system features hook-up see “Option Wiring” (page 11).

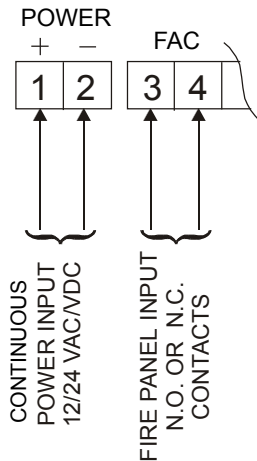

Terminals 1 & 2 - Power Input. May be 12 or 24 Volts, AC or DC, uninterrupted. Current requirement is 0.75 Amps for 12 Volts and 0.5 Amps for 24 Volts (check voltage selection jumpers “V” - page 6).

DO NOT INTERRUPT INPUT POWER (TERMINALS 1 & 2) FOR AUTHORIZED ACCESS/EGRESS. EXTERNAL ACCESS/EGRESS CONTROLS (EX. KEYPAD, CARD READER, ETC.) SHOULD USE DEDICATED BYPASS TERMINALS 7 & 8 or 9 & 10 (SEE PAGE 11).

Terminals 3 & 4 - Fire Panel Input. May be normally-open (N.O.) or normally-closed (N.C.) dry contacts from fire panel (check fire alarm control jumper “FA” - page 6).

When the fire panel trips, the lock will release, the audible will sound a constant tone and the bi-color LED (LED1) will change to green. When the fire panel is reset, the lock will reset and lock.

NOTE: DO NOT APPLY POWER TO TERMINALS 3 & 4 OR DAMAGE WILL OCCUR.

**PROPER OPERATION OF THE 3121B/B2 REQUIRES
ADJUSTMENT OF THE EGRESS SENSORS
PROCEED TO EGRESS SENSOR ADJUSTMENT**

EGRESS SENSOR ADJUSTMENT

The sensor and armature assemblies are designed for use on doors with existing mechanical latching hardware. If used on doors without latches, false alarms are possible. In these cases, we suggest using external triggers such as our 6451 Exit Sensor Bars - connect using terminals 11&12 and disable the internal sensors (see pages 10&11).

SEE PAGE 10 FOR LOCATION OF ELECTRONIC PARTS MENTIONED IN THIS SECTION

1. With both doors closed and latched apply input power to terminals 1 & 2 on Master Lock. Slide selector switch (DS1) #1 to the ON position to activate the Set-Up mode. Rotate the on-board keyswitch counter-clockwise. The lock should now be unlocked (LED1-OFF).
2. Open both doors. Temporarily remove the Adjustment Wheel Stops from the Armature Mounting Plates and close the doors. Set aside for re-installation later.
3. With the doors closed observe the bi-color LED (LED1) on the circuit board. It should be lit red. If it is not lit, rotate the adjustment wheels counter-clockwise as necessary to ensure that they will contact and fully depress the ball plungers on the lock. Rattle the doors to ensure the LED remains lit.
4. With the doors closed and LED1 lit red, unlatch and slowly open either door. The LED will shut off as soon as the door opens far enough for the ball plunger to fully project. Check that the other door operates in the same manner.
NOTE: LEDs operate in tandem - both LEDs will go out when either door is opened.

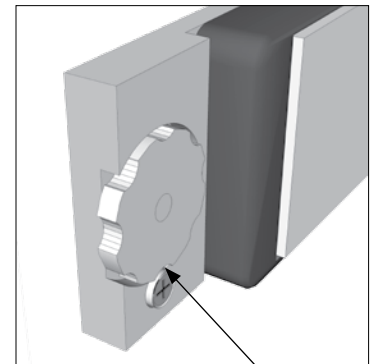
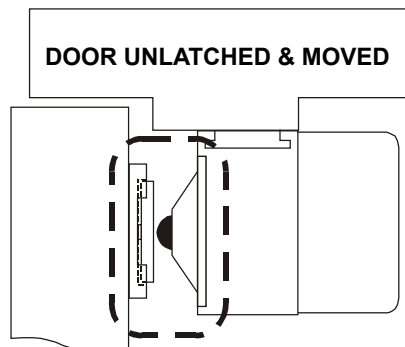
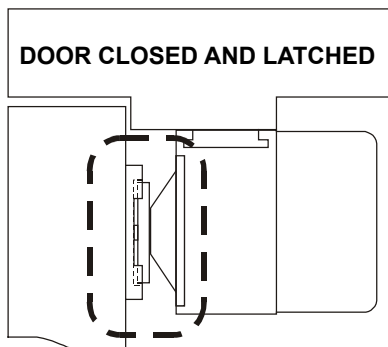
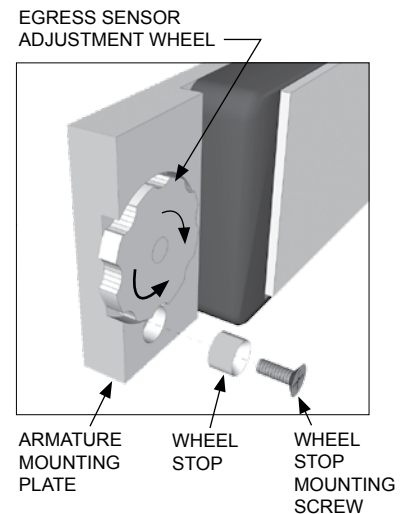

5. With adjustment completed, re-install the adjustment wheel stops to lock-in the adjustments. Close the doors, slide selector switch (DS1) #1 back to the OFF position and return the on-board keyswitch to the center position to re-lock the 3121B/B2.
6. Unlatch and push on either door until delay egress triggers (1-3 seconds). The audible will sound and LED1 will flash red. After 15 seconds, both sides of the lock will release. Turn the on-board keyswitch clockwise to reset the lock. If delayed egress triggers too soon, or fails to trigger, re-adjust the sensor adjustment wheel(s) for desired sensitivity. Check that the other door operates in the same manner.

TIP: Both sensors work together in series. You can "jump out" one sensor at a time, leaving the other sensor isolated for adjustment. Temporarily remove the jumper from the audible selector (J11) and unplug one sensor - place the jumper on the pins where the white and green wires were. Now the other sensor can be adjusted.



705 Emmett Street • Bristol, CT 06010
 1-877-DynaLock • www.dynalock.com

**MODEL 3121B/B2
 DELAY EGRESS SYSTEM**

INSTALLATION INSTRUCTIONS

BUILT-IN KEYSWITCH OPERATION

POSITION	DESCRIPTION
CENTER	NORMAL / LOCKED
CLOCKWISE (SPRING LOADED)	RESET AFTER DELAY EGRESS ALARM
COUNTER-CLOCKWISE	BYPASS / UNLOCKED WITHOUT ALARM

INDICATOR & AUDIBLE DESCRIPTIONS

**LED1 & SLAVE LED -
 BI-COLOR LED INDICATORS**
 (Located at center of each circuit board.)
 Indicates lock status and monitors door
 movement during egress sensor adjustment.

**LED2 -
 WATCHDOG LED INDICATOR**
 (Located upper right corner of master circuit board.)
 Troubleshooting indicator - monitors proper operation
 of the microprocessor.

CONDITION	AUDIBLE SIGNAL	LOCKS	LED1/SLAVE LED	LED2
DELAY EGRESS ALARM	One second pulse rate during delay cycle.	ON	BLINK RED	RED
DELAY EGRESS ALARM	Steady tone after delay until reset.	OFF	GREEN	RED
FIRE ALARM RELEASE	Steady tone until fire alarm contacts are reset.	OFF	GREEN	RED
OPTIONAL REMOTE AUTHORIZED BYPASS (TERMINALS 7&8 / 9&10)	None, unless bypass audible is enabled (dip switch 2). If door is held open past relock time, goes into delay egress alarm & requires reset.	OFF	GREEN	RED
FACTORY SERVICE REQUIRED	Steady tone.	N/A	N/A	BLINK RED OR OFF
POOR MAGNETIC BOND	Rapid pulse rate until problem is corrected (only functional with Dynastat Force Sensor option).	N/A	FAST BLINK RED	RED

OPTIONAL SET-UP

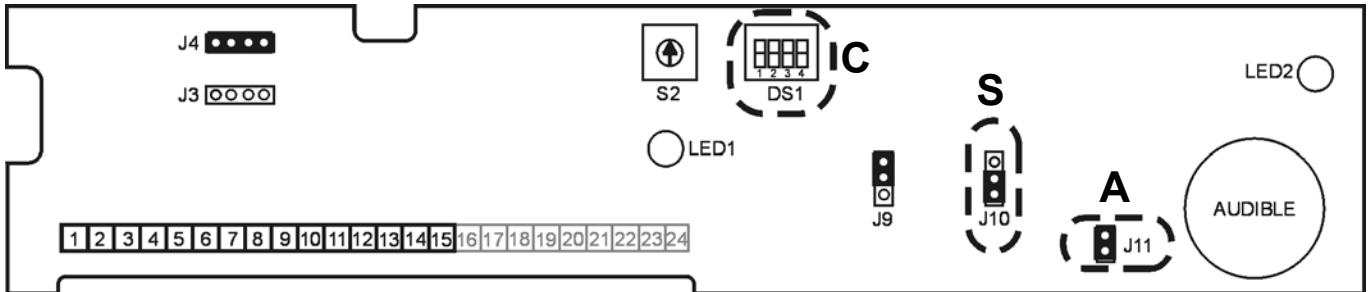

1. C- System Selector Switches

Set the System Selector Switches (DS1) to address your specific system requirements. The normal factory setting is all switches off.

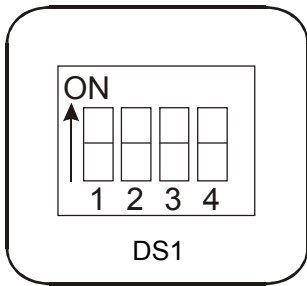

SWITCH	FUNCTION	MODE SETTINGS	
		OFF	ON
1	SYSTEM SET-UP	NORMAL	SET-UP MODE
2	BYPASS AUDIBLE *	DISABLED	ENABLED
3	NUISANCE DELAY	1 SEC.	3 SEC.
4	EGRESS DELAY	15 SEC.	30 SEC.

*Only applies to terminals 9&10 (see next page)

2. A- Audible Selector

The on-board audible is normally enabled for local signaling of lock and alarm status. To completely disable the audible remove jumper (J11).

(Factory Setting)

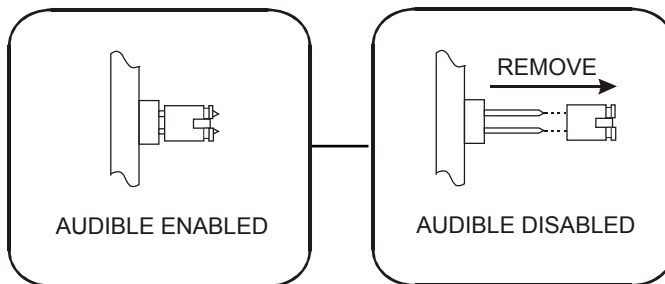

3. S- Sensor Control

The egress sensor may be disabled if you wish to trigger the lock via external remote contacts on input terminals 11 & 12. Position jumper (J10) to disable the egress sensor as shown.

(Factory Setting)

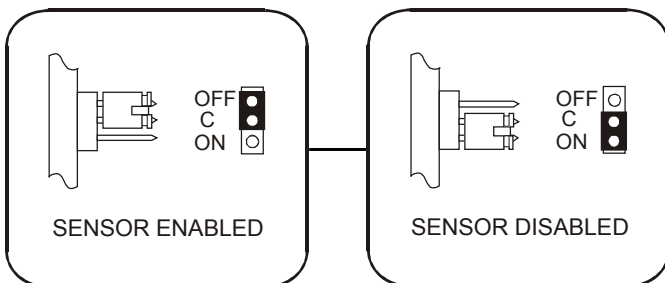

OPTION WIRING

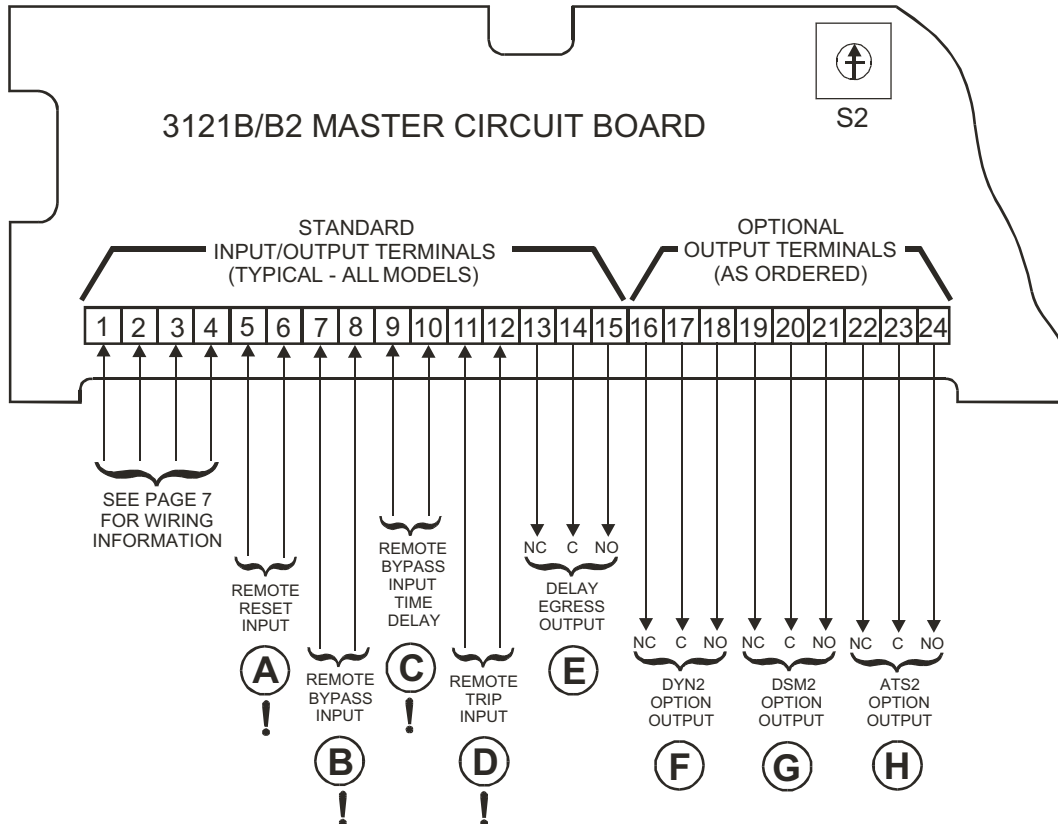

! WARNING: DO NOT APPLY POWER TO INPUTS MARKED "!" OR DAMAGE WILL OCCUR

INPUT DESCRIPTIONS

<p>(A)! REMOTE RESET INPUT</p> <p>Momentarily closing a normally-open dry contact across terminals 5 & 6 will reset and re-lock the 3121B/B2 following delayed egress and re-closure of door.</p>	<p>(C)! REMOTE BYPASS INPUT TIME DELAY</p> <p>Momentarily closing a normally-open dry contact across terminals 9 & 10 will immediately release the lock without alarm. The door will remain unlocked for a period of time controlled by on-board adjustable timer S2. To increase the delay rotate timer S2 clockwise. Range is 1 to 75 seconds (~5 sec. per click).</p>
<p>(B)! REMOTE BYPASS INPUT</p> <p>Momentarily closing a normally-open dry contact across terminals 7 & 8 will immediately release the lock without alarm. The door will remain unlocked until the contact is opened. Connect authorized access/egress control(s) here (typical).</p>	<p>(D)! REMOTE TRIP INPUT</p> <p>Momentarily closing a normally-open dry contact across terminals 11 & 12 will initiate delayed egress. This input may be used as a redundant or substitute means of triggering delayed egress if built-in sensor initiation is not desired (see page 10, note 3).</p>

OPTION WIRING

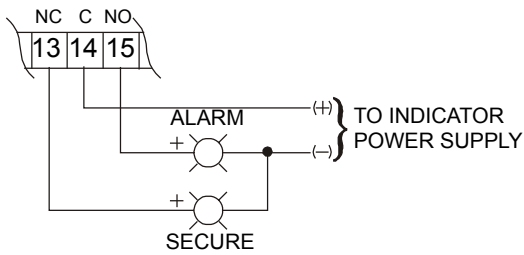
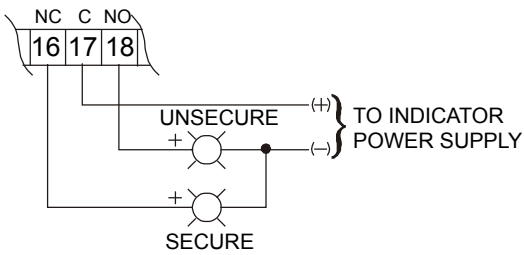
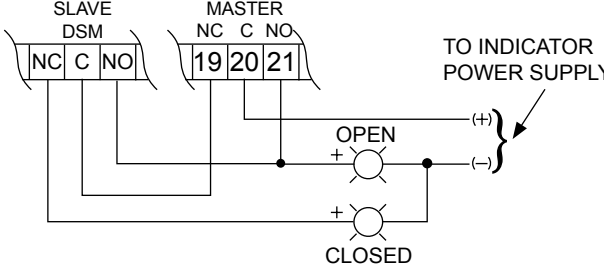
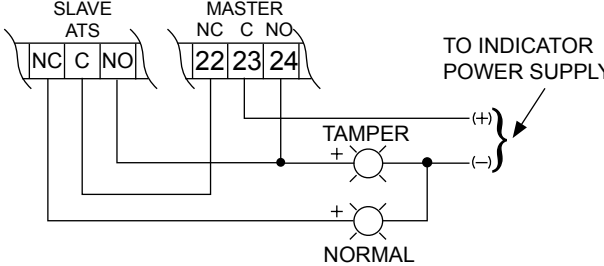
MONITORING OUTPUT DESCRIPTIONS	TYPICAL WIRING
<p>(E) DELAY EGRESS OUTPUT Delay egress alarm monitoring.</p> <p>SPDT dry relay contacts rated 1Amp @ 24 Volts</p> <p>Contacts change state upon initiation of delayed egress, after the nuisance delay has elapsed. They remain in that state until both doors are closed and reset.</p>	 <p>NOTE: INDICATORS ARE NOT INCLUDED</p>
<p>(F) DYN2 OPTION OUTPUT Dynastat bond sensor monitoring.</p> <p>SPDT dry relay contacts rated 1Amp @ 24 Volts</p> <p>Contacts change state to signal lock status as either both secure or either door unsecure. Armature misalignment can also create an unsecure condition.</p>	 <p>NOTE: INDICATORS ARE NOT INCLUDED</p>
<p>(G) DSM2 OPTION OUTPUT Door position sensor monitoring.</p> <p>(2) SPDT dry relay contacts rated 0.5Amp @ 24 Volts</p> <p>Contacts change state to signal physical door position as either closed or open. Slave side has its own connection. Both are independent circuits that do not require lock power to operate.</p>	 <p>NOTE: INDICATORS ARE NOT INCLUDED</p>
<p>(H) ATS2 OPTION OUTPUT Anti-Tamper Switch monitoring.</p> <p>(2) SPDT dry relay contacts rated 0.5Amp @ 24 Volts</p> <p>Contacts change state to signal removal of lock module's electronics cover. Slave side has its own connection. Both are independent circuits that do not require lock power to operate.</p>	 <p>NOTE: INDICATORS ARE NOT INCLUDED</p>

FACTORY WIRING - MASTER LOCK MODULE

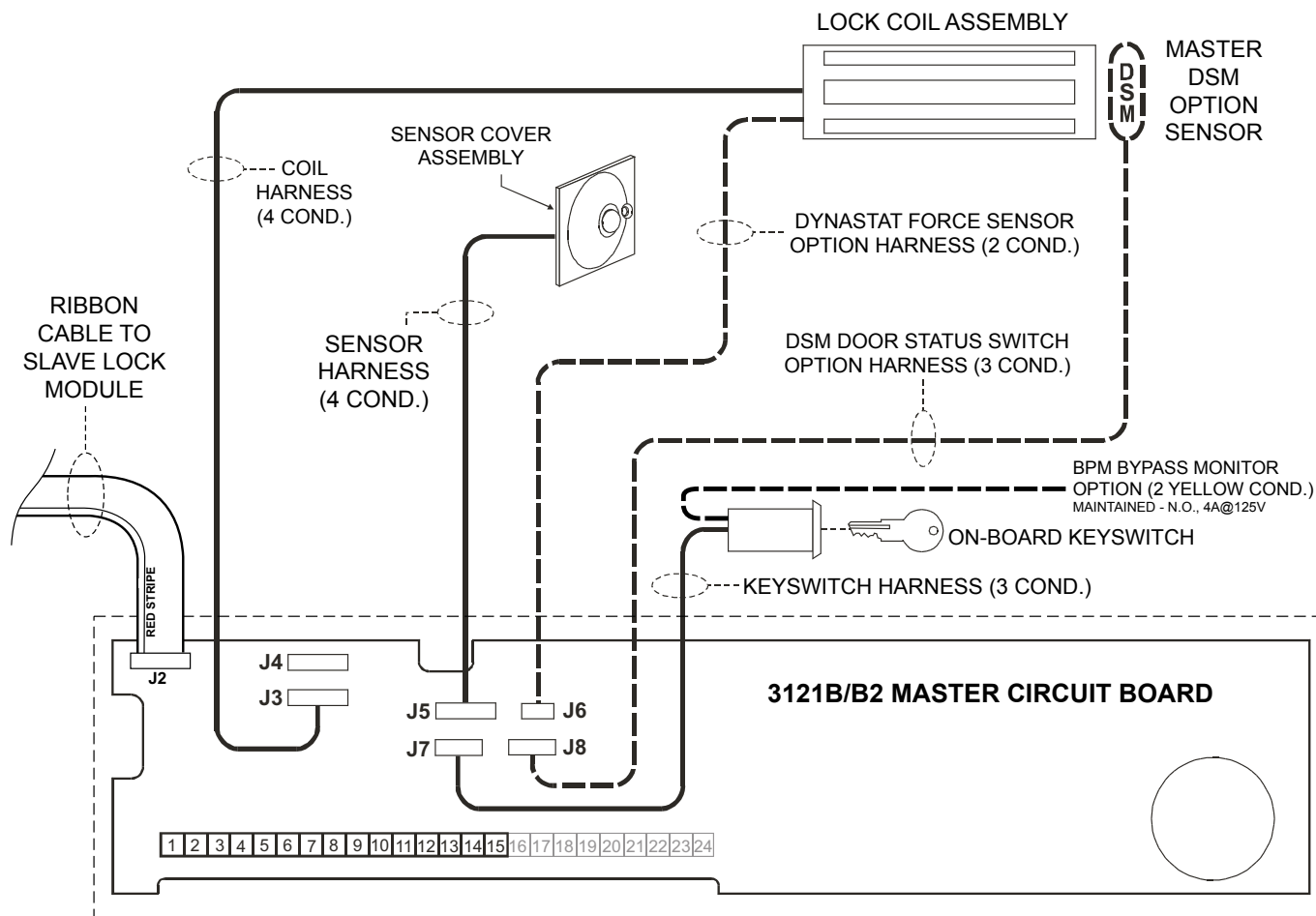

NOTES:

- Harnesses J6 and J8 are only present if the lock is equipped with the DYN2 - Dynastat Force Sensor and/or DSM2 - Door Status Switch Options.
- Observe polarity when re-connecting the J5, J7 and J8 harness connectors. Orient these connectors with respect to harness wire colors as follows:

J2	ORIENT CABLE WITH RED STRIPE TO LEFT AS SHOWN ABOVE			
J5	WHT	GRN	RED	BLK
J7	WHT	BLK	BLU	
J8	GRN	WHT	RED	
- Harness connectors J4 and J6 are not polarity sensitive.
- J3 & J4 are interchangeable - jumpers can go on J3 and coil can go on J4.

FACTORY WIRING - SLAVE LOCK MODULE

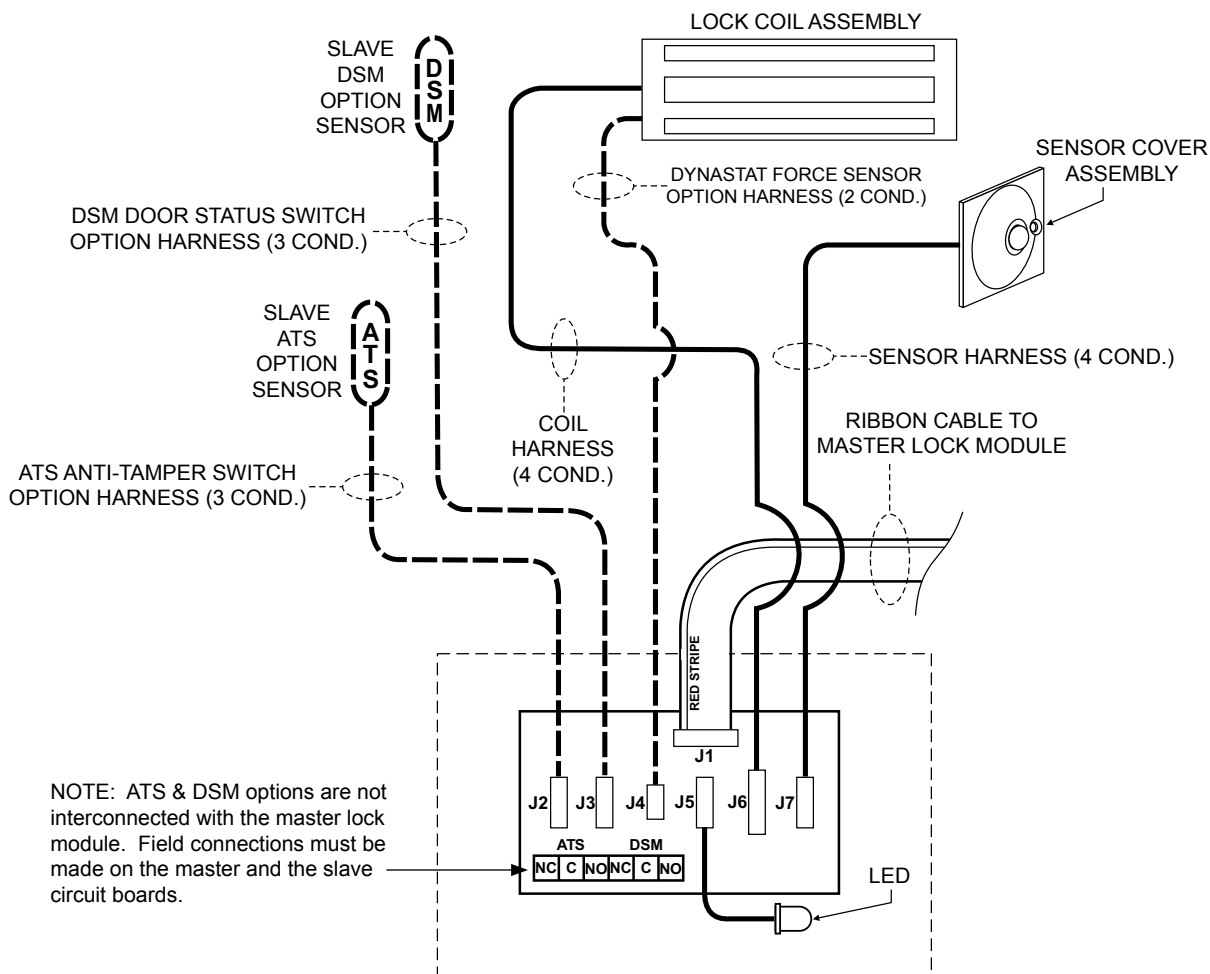

NOTES:

- Harnesses J2, J3 and J4 are only present if the 3121B/B2 is equipped with the DYN2 - Dynastat Force Sensor, DSM2 - Door Status Switch, and/or ATS2 - Anti-Tamper Switch Options.
- Observe polarity when re-connecting the J1, J2, J3, J5 and J7 harness connectors. Orient these connectors with respect to harness wire colors as follows:

J1 - ORIENT CABLE WITH RED STRIPE TO LEFT AS SHOWN ABOVE

J2	J3	J5	J7
RED	RED	GRN	WHT
WHT	WHT	BLK	GRN
GRN	GRN	RED	RED
			BLK

- Harness connectors J4 and J6 are not polarity sensitive.

EXPLODED PARTS VIEW

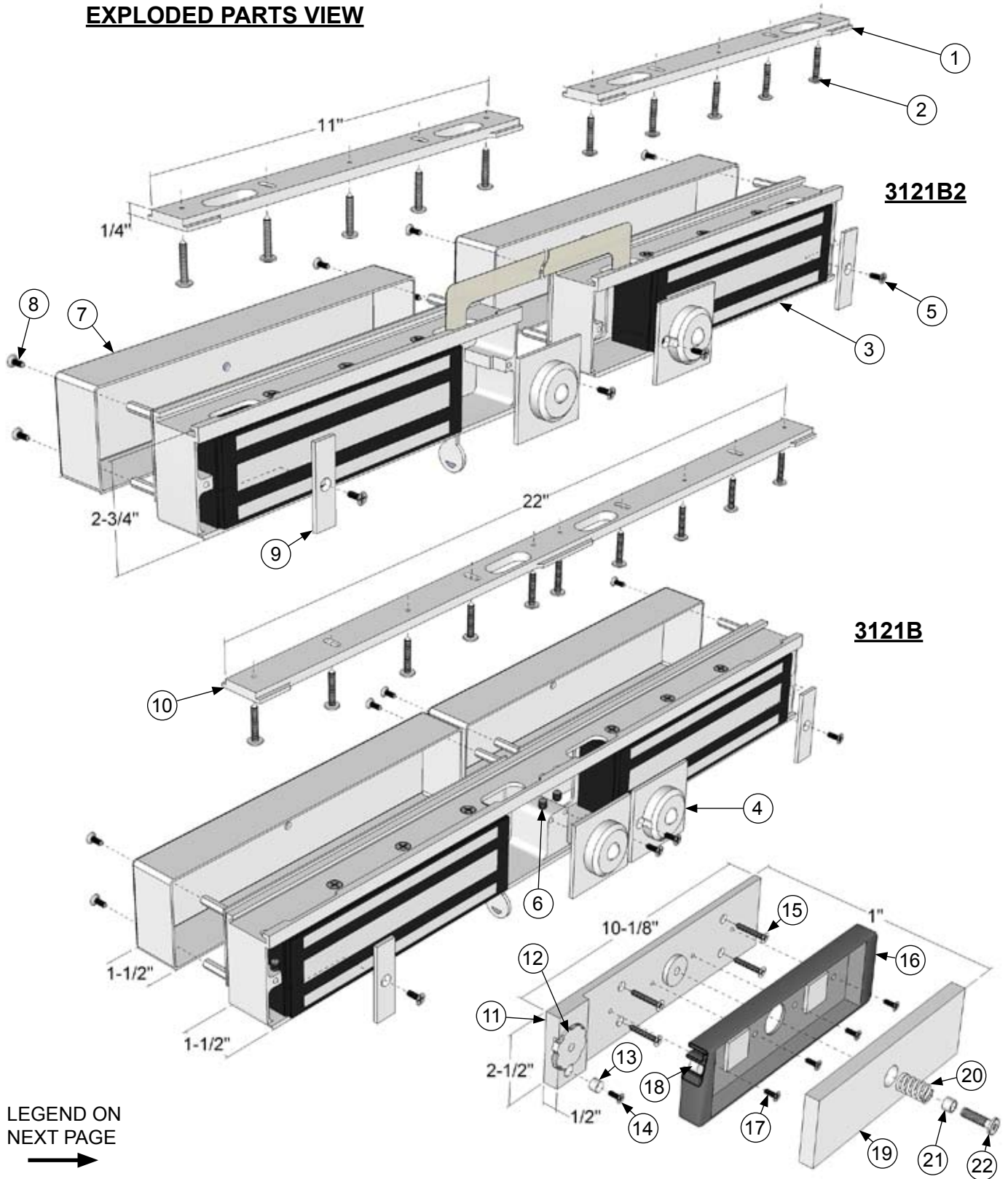

EXPLODED PARTS VIEW LEGEND

ITEM	DESCRIPTION	PART #
1	Fas-Trak Baseplate	300011
2	#10x1" Self-Tapping Screw	*
2	10-24x1/2" Machine Screw	*
3	Lock Housing	
4	Access Cover & Sensor Assembly	301037
5	8-32x3/8" Machine Screw	300608
6	1/4-28x1/4" Set Screw	300604
7	Electronics Cover	300353
8	6-32x1/2" Spanner Security Screw	700058
9	End Cover	300010
10	Double Fas-Trak Baseplate	300015

ITEM	DESCRIPTION	PART #
11	Armature Mounting Plate Assy.	301038
12	Sensor Adjustment Wheel & Stud	301383
13	Wheel Stop	301003
14	8-32x1/2" Wheel Stop Screw	301005
15	#10x1" FHS Mtg. Plate Screw	*
16	Armature Housing w/ pads	301334
17	8-32x3/8" Armature Mtg. Screw	*
18	Disc Magnet (DSM only)	301289
19	Armature	300373
20	Compression Spring	*
21	0.360"L Armature Spacer	*
22	5/16-18x1" Armature Bolt (turned)	*

* Part of Hardware Kit 301325
(the lock comes with *two* hardware kits)

Refer to Page 15 for parts locations.

PLEASE DELIVER THIS MANUAL AND THE KEYS TO THE END USER UPON COMPLETION OF THE INSTALLATION



GWXT Auxiliary Lock
FWAX Special Locking Arrangements
CSFM California State Fire Marshal

FOR PRODUCT SUPPORT AND PARTS ORDERING INFORMATION CONTACT:

DynaLock Corp.
705 Emmett Street
Bristol, CT 06010
Bus: (877) 396-2562 Toll-Free USA
(860) 582-4761
Fax: (860) 585-0338

DYNALOCK ON THE INTERNET:

E-mail: info@dynalock.com
Website: www.dynalock.com