

# 216, 216-L, 216-N

Active Infrared "Touchless" Switch

INSTALLATION INSTRUCTIONS

## Section 1

### General Description

The 216 Series "touchless" switches are active infrared devices designed for hands-free activation of automatic door operators or other access control products. The 216 switch assembly will fit in a variety of locations from a 1 3/4" door frame to a single or 2-gang or junction electrical box. Various size surface mounting boxes are also available from the factory. Three standard face plate sizes are available:

- 216: 4 1/2" x 4 1/2" stainless steel (fits single, 2-gang, junction electrical boxes)
- 216-L: 2 3/4" x 4 1/2" stainless steel (fits single gang electrical boxes)
- 216-N: 1 11/16" x 4 1/2" stainless steel (fits 1 3/4" door frames)

## Section 2

### Basic Installation

#### SINGLE GANG ELECTRICAL BOX: 216 & 216-L

- 1) Install the electrical box (purchased separately) in its intended location.
  - 2) Set the unit for its intended operating mode via the jumpers on the side of the switch assembly: Fail Close (factory setting), Fail Open or Toggle (Figure 1).
  - 3) Make the appropriate electrical connections to the switch assembly--4 wires are required (Figure 2).
  - 4) Attach the switch assembly to the electrical box with the two (2) 6-32 x 1/2" screws provided.
- MAX TORQUE 4 inch.-lbs. DO NOT OVER TIGHTEN!**
- 5) Adjust for range and time delay via the potentiometers on the front of the switch assembly (Figure 3).
  - 6) Attach face plate with the 6-32 x 3/8" screws provided ensuring that the backside of the face plate lens and the foam gasket on the front of the switch assembly are less than 1/4" apart (Figure 4).

#### 2-GANG ELECTRICAL BOX OR JUNCTION BOX: 216

- 1) Install the electrical box (purchased separately) in its intended location.
- 2) Attach the adaptor ring provided (see below) to the electrical box.

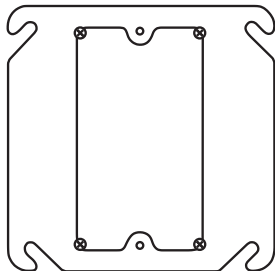

- 3) Set the unit for its intended operating mode via the jumpers on the side of the switch assembly: Fail

- Close (factory setting), Fail Open or Toggle (Figure 1).
  - 4) Make the appropriate electrical connections to the switch assembly--4 wires are required (Figure 2).
  - 5) Attach the switch assembly to the adaptor ring (mounted to the electrical box in step 2) with the 6-32 x 1/2" screws provided.
- MAX TORQUE 4 inch.-lbs. DO NOT OVER TIGHTEN!**
- 6) Adjust for range and time delay via the potentiometers on the front of the switch assembly (Figure 3).
  - 7) Attach face plate with the 6-32 x 3/8" screws provided ensuring that the backside of the face plate lens and the foam gasket on the front of the switch assembly are less than 1/4" apart (Figure 4).

#### DOOR FRAME: 216-N

- 1) Make a cutout in the door frame at the intended location. Drill and tap 2 mounting holes (see below).

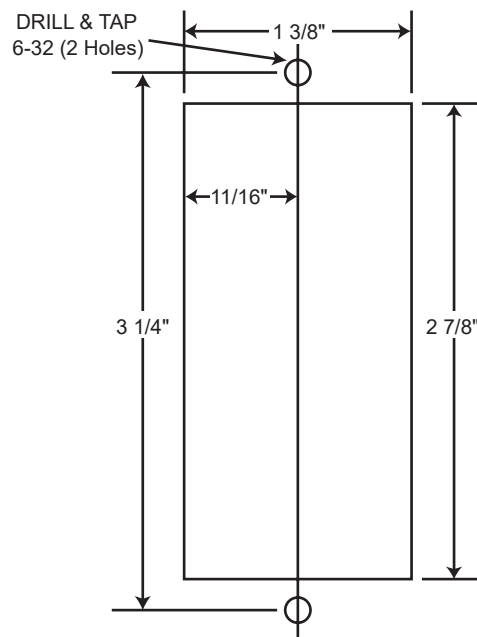

- 2) Set the unit for its intended operating mode via the jumpers on the side of the switch assembly: Fail Close (factory setting), Fail Open or Toggle (Figure 1).
  - 3) Make the appropriate electrical connections to the switch assembly--4 wires are required (Figure 2).
  - 4) Mount the switch assembly in the cutout and attach with the 6-32 x 1/2" screws provided.
- MAX TORQUE 4 inch.-lbs. DO NOT OVER TIGHTEN!**
- 5) Adjust for range and time delay via the potentiometers on the front of the switch assembly (Figure 3).
  - 6) Attach face plate with the 6-32 x 3/8" screws provided ensuring that the backside of the face plate lens and the foam gasket on the front of the switch assembly are less than 1/4" apart (Figure 4).

# 216, 216-L, 216-N

Active Infrared "Touchless" Switch

INSTALLATION INSTRUCTIONS

## Section 3

### Technical Data

Model..... 216, 216-L, 216-N  
Input Power..... 12-24V AC or DC  
Input Current.....Approx. 100 MA @ 18V AC  
Output Connections.....8" 22 AWG Leads  
Output Rating.....Form C, Rated at 3 Amps  
Detection Scheme..... Coded Modulated Carrier  
Codes Available..... Automatic Self Changing ID  
Coding  
Activation Time..... <0.03 seconds  
Reaction Time..... 0.05 - 1 second  
Operating Distance.....6" to 30"  
Temperature Rating..... -13 °F to 140 °F  
(-25 °C to 60 °C)  
Weight..... <0.25 lbs.  
Physical Size..... 1 5/16"L x 4"W x 1 1/4"H

## Section 4

### Warranty

MS SEDCO guarantees this product to be free from manufacturing defects for 1 year from date of installation. Unless MS SEDCO is notified of the date of installation, the warranty will be in effect for 1 year from the date of shipment from our factory. If, during the first year, our motion detector or support device fails to operate and has not been tampered with or abused, the unit can be returned prepaid to factory and it will be repaired free of charge. After 1 year, the unit will be repaired for a nominal service charge. **This limited warranty is in lieu of all other warranties expressed or implied, including any implied warranty of merchantability, and no representative or person is authorized to assume for MS SEDCO any other liability in connection with the sale of our products. All warranties are limited to the duration of this written warranty. In no event shall MS SEDCO be liable for any special, incidental, consequential or other damages arising from any claimed breach of warranty as to its products or services.**

**Questions? Call us at 1-317-842-2545 or  
visit us online at [www.mssedco.com](http://www.mssedco.com).**



# 216, 216-L, 216-N

Active Infrared "Touchless" Switch

INSTALLATION INSTRUCTIONS

**FIGURE 1—Operating Modes Diagram**

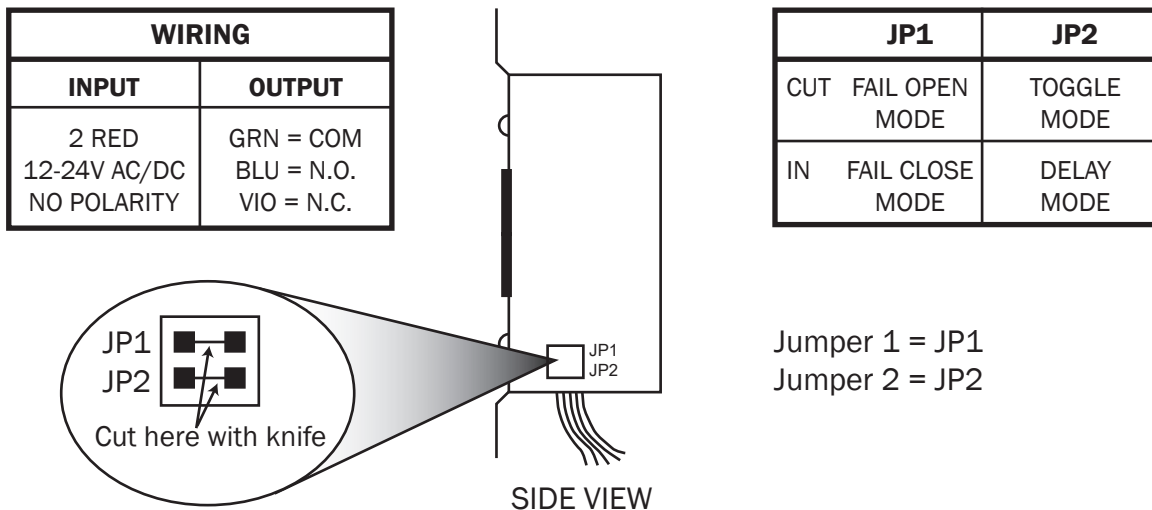

- 1) **Standard "Fail Close" Mode (Factory Setting):** This is the most common operating mode. In this mode, if power were to fail to the 216 series switch, the door it is activating will stay closed (the switch relay is in its inactive state). The unit is shipped from the factory in this mode - no change to the jumpers is necessary. Wire connections are COM and N.O.
- 2) **Optional "Fail Open" Mode (Cut Jumper 1):** In this mode, if power were to fail to the 216 series switch, the door it is activating will open (the switch relay is in its active state). In order to program this mode, cut Jumper 1. Wire connections are COM and N.C.
- 3) **Toggle Mode:** In this mode, when the 216 series switch is activated, the relay is energized and maintains that state until it is activated again, returning the relay to its de-energized state. For example, a 216 series switch could be located at the entrance of a room. When a person enters, the 216 series switch turns on the light. As they exit, the 216 series switch turns off the light. In order to program this mode, cut Jumper 2. Wire connections are COM and N.O.

**FIGURE 2—Wiring Diagram**



**Input Connections**

12-24V AC or DC  
Red and black wires have no polarity on this product.  
Do not tie either of the power supply lines to ground.  
The power in must "float" and not be grounded.

**Output Connections**

Green = Common (COM)  
Blue = Normally Open (N.O.)  
Violet = Normally Closed (N.C.)

**Fail Close Mode (Factory Setting):** Wire connections COM & N.O.

**Fail Open Mode:** Cut Jumper 1; wire connections COM & N.C.

**Toggle Mode:** Cut Jumper 2; wire connections COM & N.O.

# 216, 216-L, 216-N

Active Infrared "Touchless" Switch

INSTALLATION INSTRUCTIONS

### FIGURE 3—Adjustments Diagram

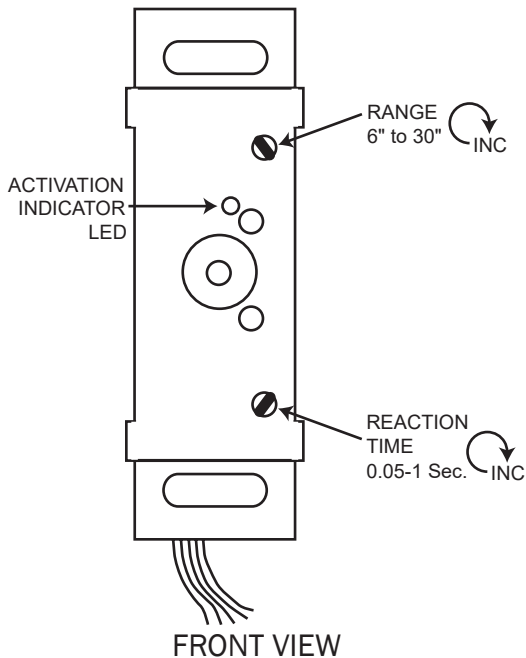

Range Adjustment: Clockwise to increase 6" to 30".



**NOTE:** When attaching the face plate, the range may increase.

Reaction Time Adjustment: Clockwise to increase 0.05 to 1 second.

### FIGURE 4—Face Plate Installation Diagram



**WARNING:** For proper operation, the backside of the face plate lens must be no more than 1/4" from the foam gasket on the switch assembly (no more than 1/4" of space between the lens and the foam gasket). For optimum performance, the lens and foam gasket should be touching.



**WARNING:** When attaching the face plate to the switch assembly, only use 6-32 x 3/8" screws provided. Use of longer screws may cause damage to the unit.

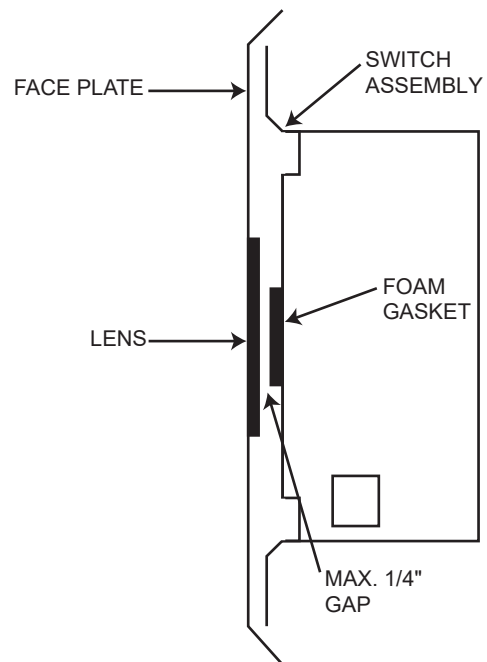

SIDE VIEW