

SDC Security Door Controls

801 Avenida Acaso, Camarillo, Ca. 93012 • (805) 494-0622 •
www.sdcsecurity.com • E-mail: service@sdsecurity.com

INSTALLATION INSTRUCTIONS EXIT CHECK® DELAYED EGRESS EMLOCK® 1511S / 1511T

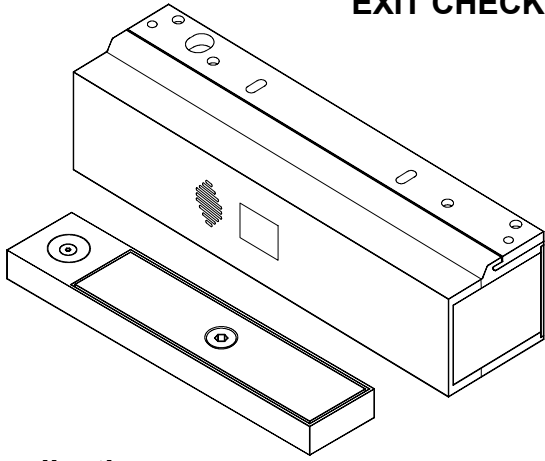

**PUSH UNTIL ALARM
SOUNDS. DOOR CAN BE
OPENED IN 15 SECONDS.**

**KEEP PUSHING. THIS DOOR
WILL OPEN IN 15 SECONDS.
ALARM WILL SOUND.**

California Building
Code Compliant

Application

When unauthorized egress is initiated, the Exit Check® delays egress through the door for a period of 15 or 30 seconds. An integral digital countdown display and voice commands inform the person intending to exit of the seconds remaining to unlock. Meanwhile, the person exiting must wait allowing personnel or security respond. The door unlocks after the 15 or 30 second delay period has elapsed, permitting egress. A signal from the fire/life safety system will release the lock immediately for uninhibited egress in an emergency.

Exit Check® applications include:

- Restricting the egress of patients for their own safety.
- Restricting the egress of commercial center patrons for security application needs.
- Controlling pedestrian traffic in transportation facilities, including airport jetways and tarmacs

Standard Features

1650 lbs. Holding Force
15 or 30 Second Exit Delay when activated.
1 or 2 Second Nuisance Delay
75dB Alarm Tone with Digital Display & Selectable Voice
Instruction

Choice of Activation Trigger:

- Door Movement
- Exit Device w/ REX Switch
- Touch Sense Bar w/REX Switch

Auto Power-Up – Occurs when power is restored and/or the fire panel is restored. (When Allowed by Code)
Manual Power-Up – *This is a UBC & California Building Code Compliant Feature* – Only after power restoration and fire panel reset may the lock be reset manually at the opening. Lock can be reset with the built-in reset key switch or, a key switch or keypad adjacent to the door.

Vandal resistant Proximity Sensor Trigger
Auto Sensing 12/24VDC input power
Connection for Tandem Option (Pairs of Doors)

Optional Features

D = DPS Door Position Switch
B = BAS Bond Alert Sensor
A = ATS Anti Tamper Switch
E = Energy Saver Option (1200 lb. Holding Force)

Building & Fire Life Safety Code Compliant

IBC International Building Code
IFC International Fire Code
NFPA 101 Life Safety Code
NFPA 1, UFC, Uniform Fire Code
UBC Uniform Building Code
CBC California Building Code
SBC Standard Building Code
BOCA National Building Code compliant
Chicago Building Code compliant



Only the 1511S and the 1511T have been UL listed as Special Locking Arrangements to UL Standard 294, and NFPA 101.



California State
Fire Marshal Listed
CSFM #3774-0324:103

1511S Operational Description

The door is closed and secured by latching hardware. The model 1511S Exit Check locks the door in the secured position, and the display shows the unlock delay time.

Activation / Alarmed Release :

Activation of the 1511S Exit Check's 15 or 30 second unlock cycle is started by releasing the door latch and applying up to 15 lbs. of pressure to the door causing slight door movement. A short nuisance delay period is then initiated, a pre-activation warning tone is sounded and the integral display will start counting down. To prevent false alarms, re-latching the door during the nuisance delay period will silence the pre-activation warning tone, reset the countdown display and keep the door locked.

Once the nuisance delay period has been exceeded, the Exit Check continues with an irreversible door release cycle. The integral digital countdown display and voice commands continue to inform the person intending to exit of the seconds remaining until unlock and an alarm output is activated to alert personnel of an unauthorized exit. After the 15 or 30 second delay cycle has expired, the Exit Check will release the door allowing free egress.

Reset / Relock:

The Exit Check can be manually reset by authorized personnel by closing the door and activating the integral reset key switch or by momentarily activating a N/O switch connected to the remote reset terminals.

Request to Exit / Authorized Bypass:

Momentarily actuating the integral key switch to the bypass position or momentarily activating a N/O switch connected to the REX terminals will initiate the request to exit cycle and unlock the 1511S Exit Check allowing free egress. After the request to exit cycle has expired, the Exit Check will automatically relock.

Leaving the integral key switch in the bypass position or placing a maintained closure across REX terminals will reset the request to exit cycle and keep the 1511S unlocked for extended periods of time. Releasing the remote contact or returning the integral key switch to the center position will restart the request to exit cycle and will relock the door after the request to exit time has expired.

(NFPA-101)

The 1511S operation complies with the following building and fire codes: NFPA 101; NFPA 1-UFC; UBC; IBC; IFB; SBC; CBC (California Building Code). Listings: UL Listed: Special Locking Arrangements and Auxiliary Locks; California State Fire Marshal (CSFM) Listed.

Option Code	Delay Release Time	Nuisance Time	Reset after Alarm	Lock Status on Power-Up
NA	15 sec or 30 sec Selectable	1 sec or 2 sec Selectable	Manual	Locked or Unlocked Selectable
ND	15 sec Fixed	0 sec or 1 sec Selectable	Manual	Locked or Unlocked Selectable
NH	30 sec Fixed	0 sec or 1 sec Selectable	Manual	Locked or Unlocked Selectable
NC (CBC Compliant)	15 sec Fixed	0 sec or 1 sec Selectable	Manual	Unlocked Fixed

Per BOCA compliance, the Exit Check is manually reset by authorized personnel after an alarm by closing the door and actuating the integral reset key switch or by momentarily closing a contact connected to the remote reset terminals. In addition, reset will be automatically initiated once the door has been opened, then closed and remains closed for 30 consecutive seconds.

(BOCA/Chicago)

The 1511S operation complies with BOCA National Building Code and the Chicago Building Code: UL Listed, Special Locking Arrangements and Auxiliary Locks.

Option Code	Delay Release Time	Nuisance Time	Reset after Alarm	Lock Status on Power-Up
BD	15 sec Fixed	0 sec or 1 sec Selectable	Auto/Manual	Locked or Unlocked Selectable
BH	30 sec Fixed	0 sec or 1 sec Selectable	Auto/Manual	Locked or Unlocked Selectable
BC (CHICAGO)	15 sec Fixed	0 sec Fixed	Auto/Manual	Locked or Unlocked Selectable

Specifications

Interior Applications Only

Input Voltage Requirements:

Dual Voltage (Auto Sensing) –
12/24 VDC (+/- 10%)

(Use with a UL 294 Standard Power Supply)

Power Consumption:

Standard Model (1650 lbs.) -
1511S – 820/500 mA @ 12/24 VDC
1511T – 1500/850 mA @ 12/24 VDC

Energy Saver (1200 lbs., "E" Option) –
1511S – 452/274 mA @ 12/24 VDC
1511T – 660/486 mA @ 12/24 VDC

Size: 11"L x 2-3/4"H x 2-5/8"D

Lock Status Relay Rating: 1 Amp @ 30V resistive

Alarm Output Rating: 1 Amp @ 30V resistive

DPS Rating: 250 mA @ 30V resistive

BAS Rating: 250 mA @ 30V resistive

ATS Rating: 1 Amp @ 30V resistive

Operating Condition: 0-49 deg C, 85% RH
(non-condensing)

Included in Package

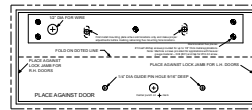

TEMPLATE
TEMP-1511

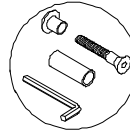

ARMATURE
SCREW PACK
1580S-101-C

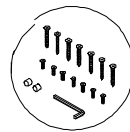

EMLOCK
SCREW PACK
C-1500

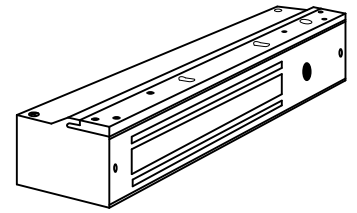

1511S EMLOCK
HOUSING ASSY. &
MOUNTING PLATE

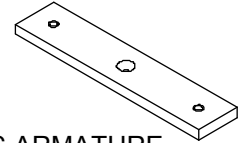

1511S ARMATURE
1511S-12T

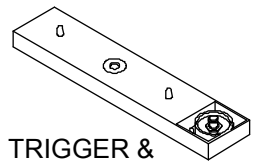

1511S TRIGGER &
ARMATURE BASE
1511S-11

Suggested Optional Equipment

Digital Entry



918 Digital Keypad
Two relay outputs:
Relay 1 -Reset;
Relay 2 – Choice of
momentary or
sustained bypass.

Remote Speaker

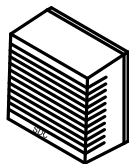

101-SP
Indoor Surface Mount;
85dB@3ft.;
Compact Design (4 in. sq.);
Plug-in connector included
for easy installation

Power Supply

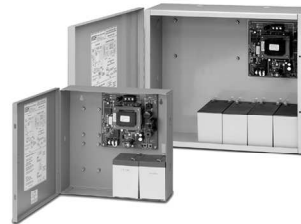

600 Series Power Supply

Field Selectable 12 or 24VDC modular
Power Supplies with Fire/Life Safety
Emergency Release. Tri-colored LED,
separate PTC protected outputs, battery
charger, and Class 2 Outputs.

602RF 1 Amp
631RF 1.5 Amp
632RF 2 Amp
634RF 4 Amp
636RF 6 Amp

Station Controls, Annunciator Panels, and Consoles



728
Single station two
function key switch
control for alarm
reset and access or
sustained bypass.



101-1A
The single station
annunciator is
equipped with a tri-
colored LED and
audible alarm.



101-PAM
Visual & audible
annunciation, timed
access, sustained
bypass and audible
mute.



728-L
Single station two
function key switch
control for alarm reset
and access with a tri-
colored LED showing
door condition.



101-4AM
Provides visual &
audible annunciation
with audible mute for
one, two, three or
four openings.



TCC Desk Top : Stations 4, 8, & 12

SDC Annunciator Consoles
provide remote annunciation
of multiple openings. Stations
are specified in sets of four.
Control switches are capable
of both sustained bypass and
timed unlocking.



702-R
Single station one
function key switch
control for alarm
reset.



101-1AK
Visual & audible
annunciation and a
two function key
switch for alarm reset
and access or
sustained bypass.



PSB560

Request-to-exit pressure
sense non-latching bar
that will activate the Exit
Check® when slight
pressure is applied to
the bar. For doors
without latching.

Door and Frame Preparation Instructions

STEP 1. Locate the paper template and fold along the dotted line. Place the folded edge of the template against the door stop and door at the header while against the vertical stop, opposite the hinge side of the door. Tape in place at this position.

STEP 2. As indicated on the paper template, punch the designated hole locations on the frame and armature mounting holes on the door. **(NOTE: PRIOR TO DRILLING, INSPECT TO SEE IF ANY OF THE HOLES CANNOT BE DRILLED DUE TO THE FRAME OR DOOR CONFIGURATION. A FILLER PLATE OR ANGLE BRACKET MAY BE REQUIRED. SEE PAGE 4.)**

STEP 3. Drill and tap the two 1511S mounting holes as indicated on the paper template. **(NOTE: READ NOTE ON TEMPLATE WITH REGARD TO SELECTING THE PROPER HOLE SIZE FOR ARMATURE MOUNTING BOLT.)**

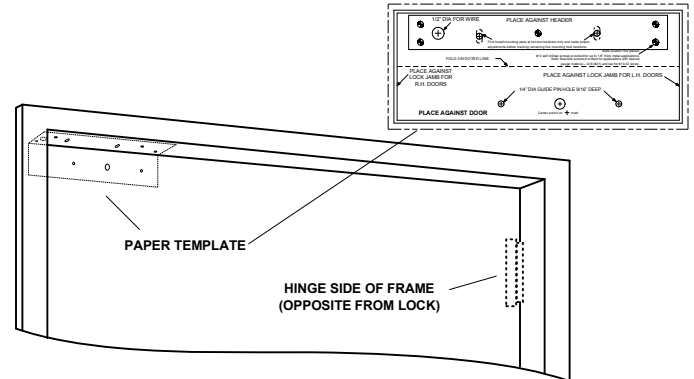
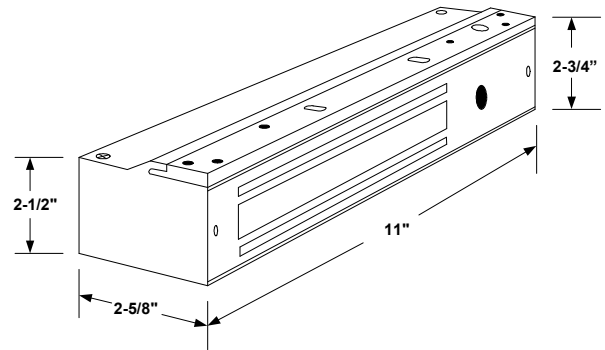

Door and Frame Reference

IMPORTANT! – IT IS HIGHLY RECOMMENDED THAT YOU FIRST INSTALL THE MOUNTING PLATE AT TWO SLOT LOCATIONS ONLY. THIS WILL ALLOW YOU TO MAKE PROPER ADJUSTMENTS OF THE LOCK'S POSITION PRIOR TO MARKING, DRILLING AND TAPPING THE FOUR PERMANENT MOUNTING PLATE HOLES.

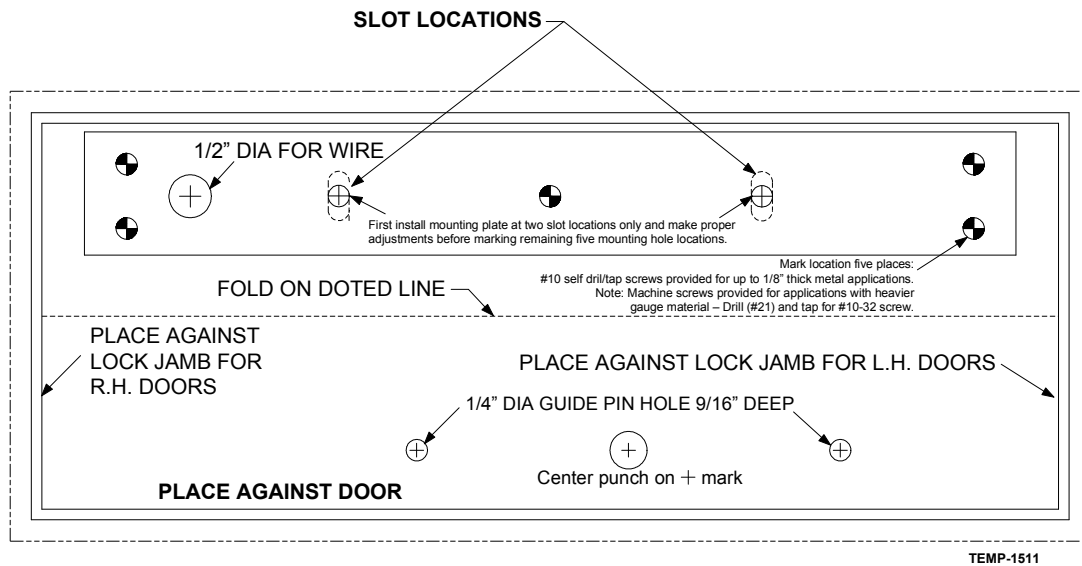

NOTES:

- #10 self drill/tap screws provided for up to 1/8" thick metal applications
- For applications with heavier gauge material, drill (#21) and tap for #10-32 machine screws.

ARMATURE MOUNTING INSTRUCTIONS

STEP 1. Mount armature to door. (See figures 2A, 2B & 2C.)

STEP 2. Install the mounting plate (filler plate and/or angle bracket if needed – see figures 1A, 1B & 1C) to header with only the two screws at the slotted hole locations at this time. Snug the screws down lightly (do not torque) so the mounting plate & lock can be repositioned later.

STEP 3. Temporarily install the lock to the mounting plate with the 1/4-20 socket head screws encased in the lock.

STEP 4. With the lock mounted, close the door so the armature holder just comes into contact with the face of the lock. If the door is not completely closed when the lock & armature touch, open the door and reposition the lock away from the door as described in step 2. **(THIS IS TO PREVENT THE DOOR FROM USING THE LOCK AS THE DOOR STOP.)**

STEP 5. Remove the lock from the mounting plate, mark & punch all remaining screw and wiring holes. Drill & tap holes as indicated on the paper template and install all screws.

STEP 6. Reinstall the lock to the mounting plate. At this point, if there is no need to remove the lock for painting or any other reason, install the anti-tamper plugs over the socket head mounting screws, using a soft hammer to avoid damage to the lock case.

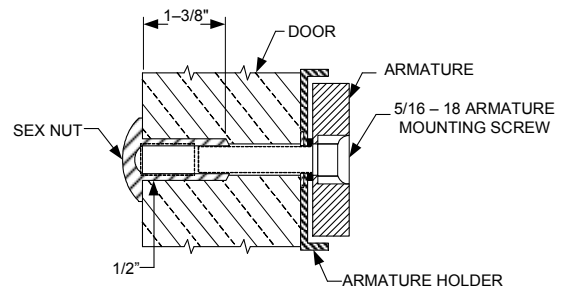

Figure 2A – SOLID DOOR

Drill exactly 3/8" diameter through the door. From sexnut side of door, drill 1/2" diameter hole 1-3/8" deep. Mount armature to door with hardware provided per Figure 2A.

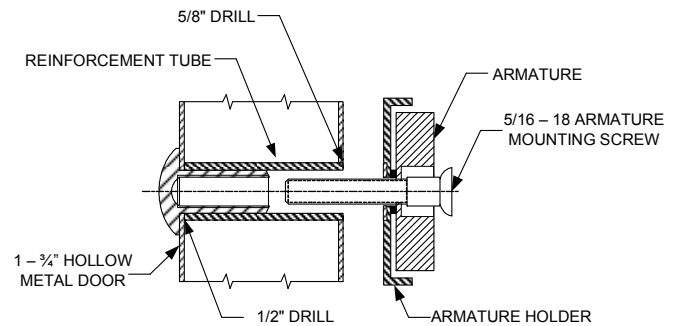

Figure 2B – HOLLOW METAL DOOR

From sexnut side of door, drill exactly 1/2" hole through one metal thickness only. From armature side of door, drill 5/8" hole to insert reinforcement tube. Press in sexnut & reinforcement tube all the way and mount armature to door using hardware provided per Figure 2B.

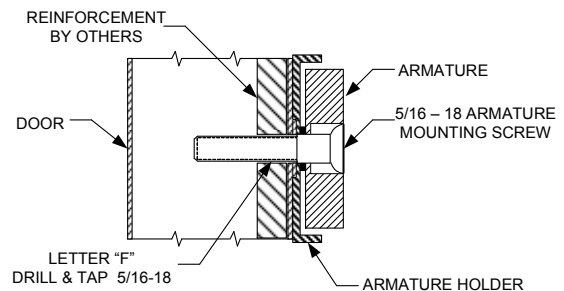
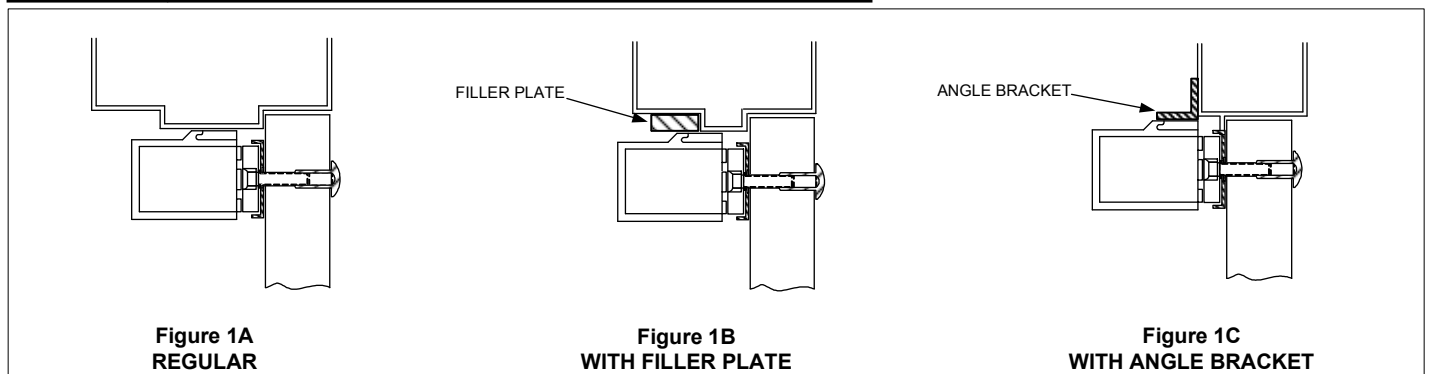

Figure 2C – REINFORCED ALUMINUM OR HOLLOW METAL DOOR

Use letter "F" drill and tap for 5/16-18 machine screw. Mount armature to door with hardware provided per Figure 2C.

REGULAR, FILLER PLATE & ANGLE BRACKET DETAILS



Typical System Wiring – Single Door (Model 1511S)

Display Modes

- 15 Door armed and locked.
- 00 Alarm countdown has ended, door is unlocked and alarm sounding until reset.
- Door unlocked and alarm is shunted (REX or Bypass)
- ⋮ Door has been opened after REX, Bypass or Alarm.

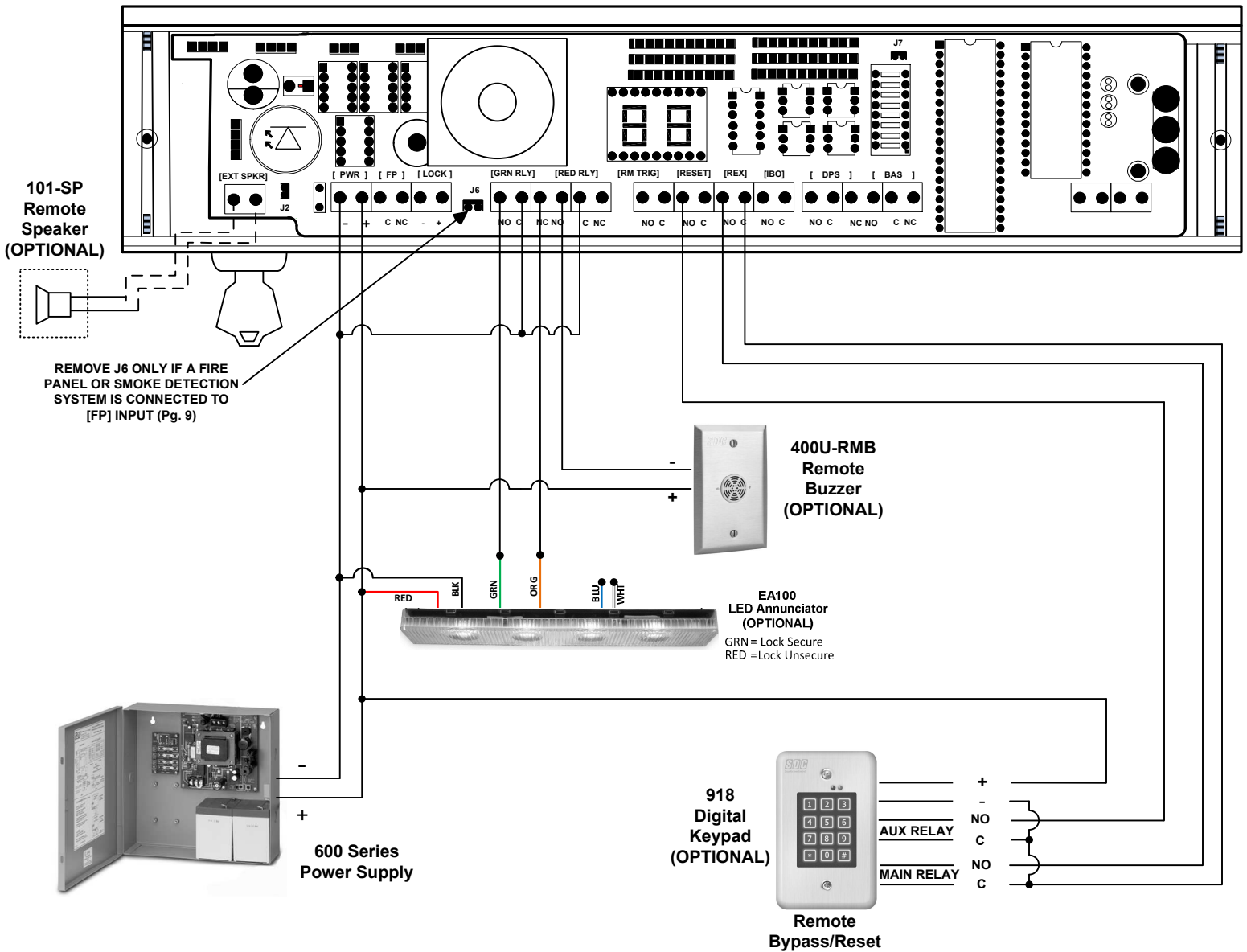
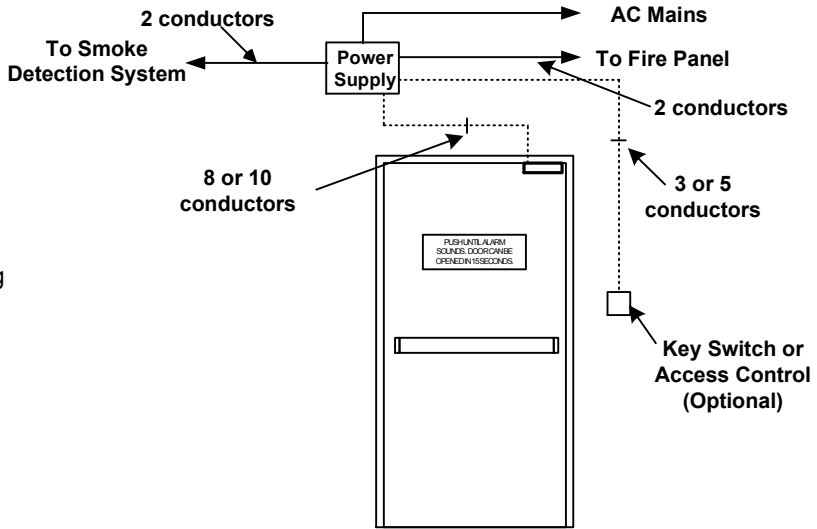

Typical System Wiring – Pair of Doors (Model 1511T)

Display Modes

- 15 Door armed and locked.
- 00 Alarm countdown has ended, door is unlocked and alarm sounding until reset.
- Door unlocked and alarm is shunted (REX or Bypass)
- ::: Door has been opened after REX, Bypass or Alarm.

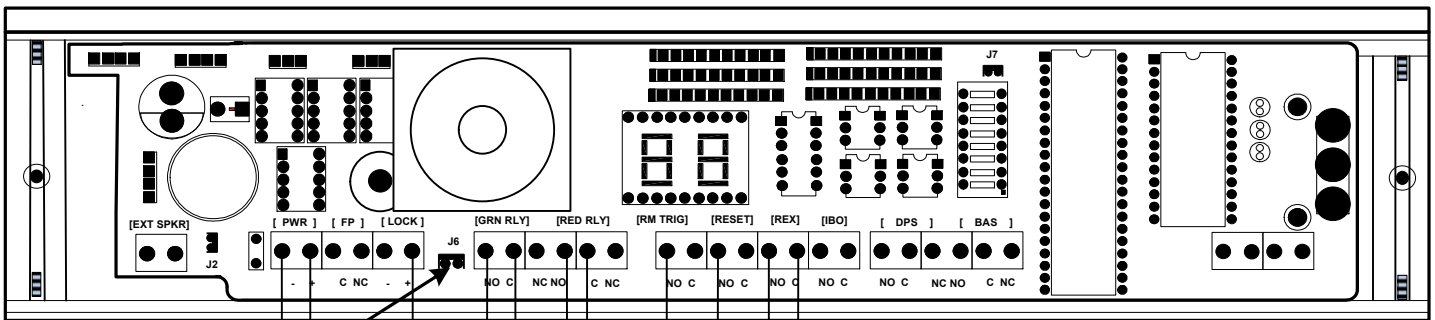
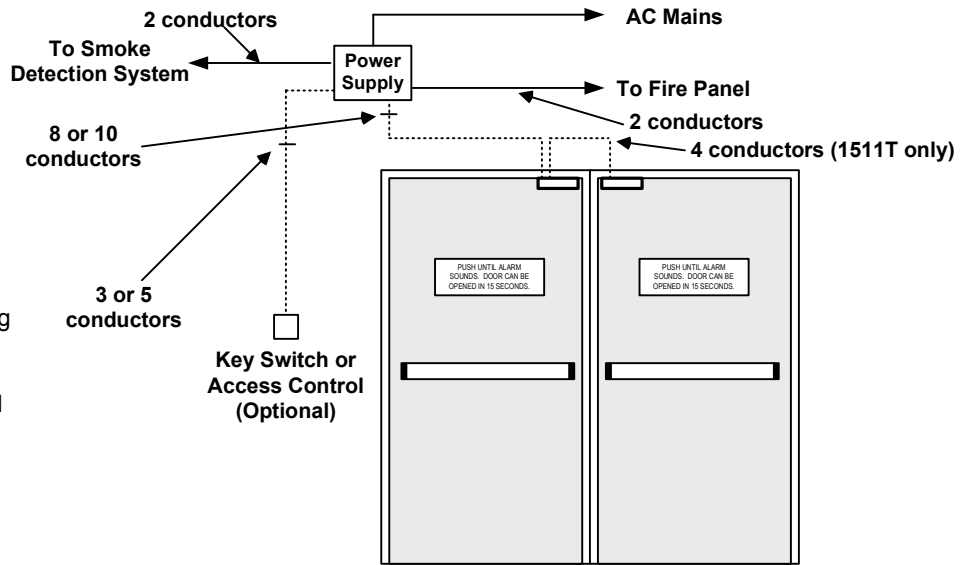

REMOVE J6 ONLY IF A FIRE PANEL OR SMOKE DETECTION SYSTEM IS CONNECTED TO [FP] INPUT (Pg. 9)



600 Series Power Supply



918 Digital Keypad (OPTIONAL)



728U or 728UL3 Key Switch Reset Station (OPTIONAL)

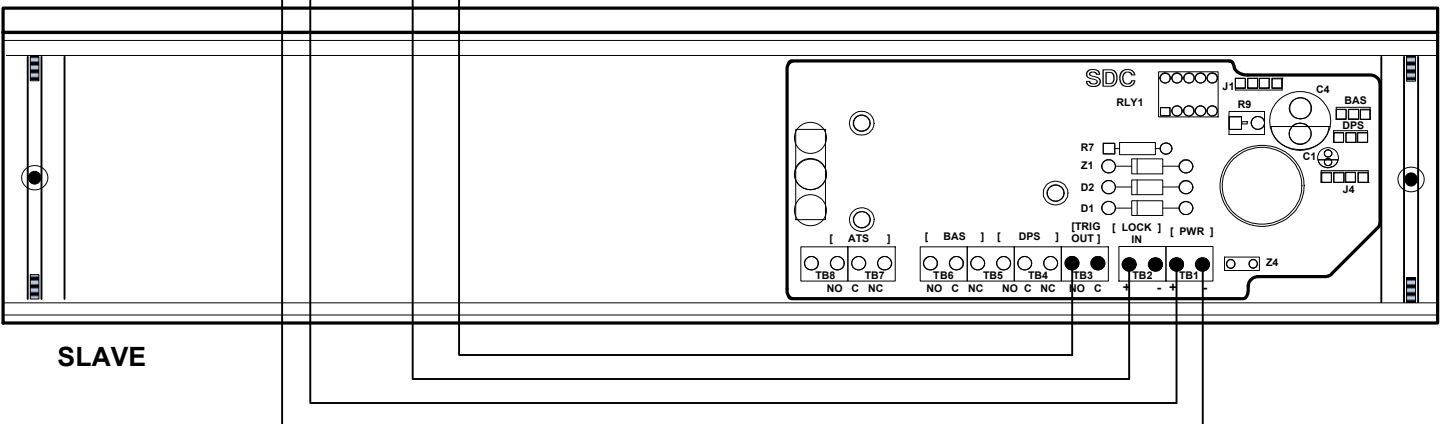

SLAVE

Wiring to Infant & Patient Protection Systems

System Operation

1. Close and hold REX input. The 1511S will be in the Bypass mode and will be unlocked.
2. Whenever the IBO input is closed and held, the 1511S will instantly relock and rearm. Egress is possible as the normal 15/30 sec delayed unlock.
3. Releasing the IBO input will return the 1511S to the Bypass mode.
4. Releasing the REX input will rearm the system.
5. Upon power-up, you must manually reset the lock to activate the IBO input.

Connection to a Infant/Patient Monitoring Systems has not been investigated by UL.

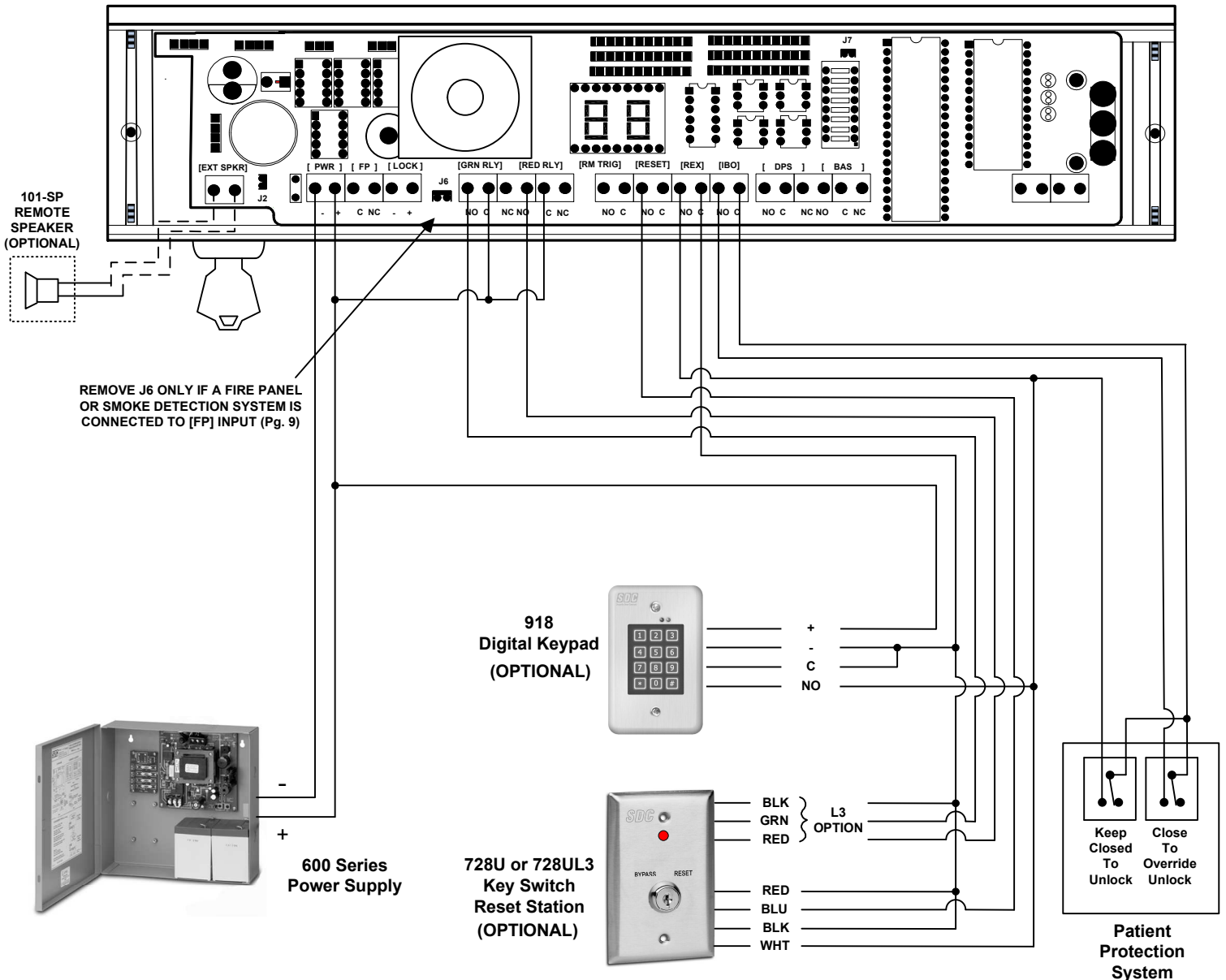
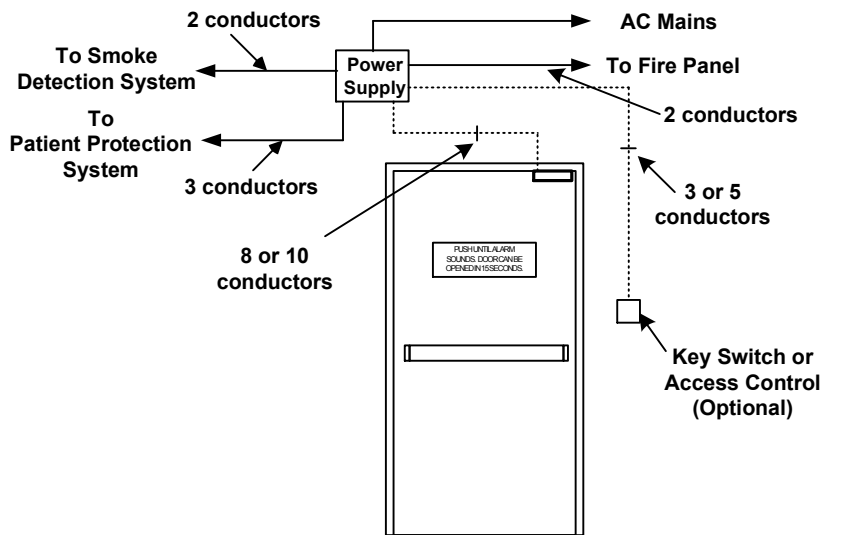

Wiring Details & Functions (ALL OPTIONS SHOWN)

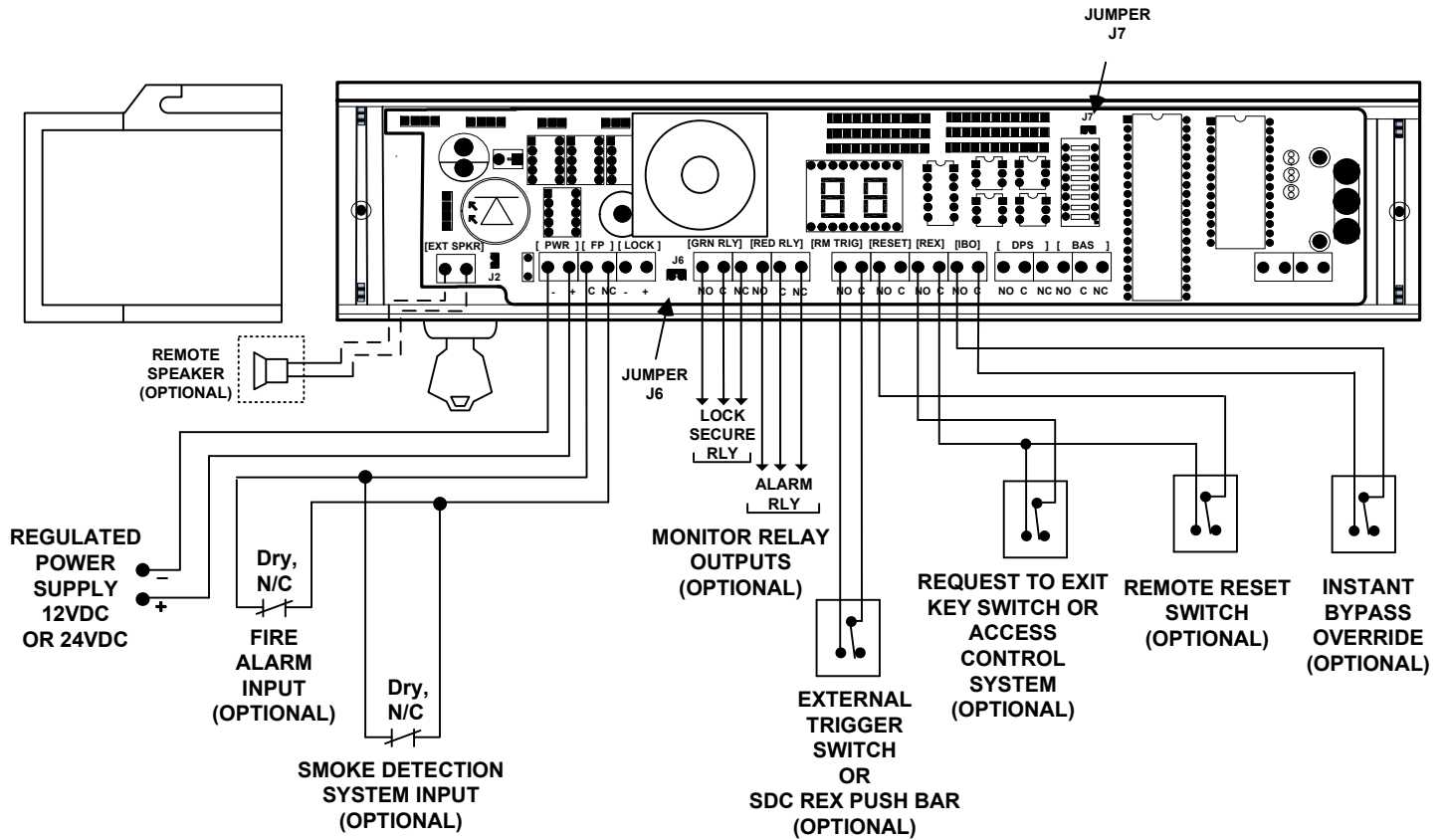

TERMINAL BOARD CONNECTIONS		
[PWR]	POWER IN - POWER IN +	12 VDC OR 24 VDC
[FP]	COM N/C	TO CLOSED FIRE/SMOKE DETECTOR CONTACT
[LOCK]	AUX LOCK - AUX LOCK +	SLAVE/TANDEM LOCK POWER TERMINALS
[GRN RLY]	N/O COM N/C	LOCK SECURE OUTPUT
[RED RLY]	N/O COM N/C	ALARM OUTPUT
[RM TRIG]	N/O COM	EXTERNAL TRIGGER SWITCH INPUT
[RESET]	N/O COM	EXTERNAL RESET SWITCH INPUT
[REX]	N/O COM	REQUEST TO EXIT INPUT
[IBO]	N/O COM	INSTANT BYPASS OVERRIDE INPUT

MONITOR RELAY OUTPUT CONFIGURATIONS	
LOCK STATUS	RELAY STATE
SECURE	GRN RLY = ON RED RLY = OFF
ALARMED & LOCKED	GRN RLY = ON RED RLY = ON
ALARMED & UNLOCKED	GRN RLY = OFF RED RLY = ON

MONITORING OPTIONS		
[DPS]	N/O Com N/C	DOOR POSITION SWITCH (DPS)
[BAS]	N/O Com N/C	BOND ALERT (BAS)
[ATS]	N/O Com N/C	ANTI-TAMPER SWITCH (ATS)

JUMPER SETTINGS

JUMPER J6 (Fire Alarm Input) – Factory Installed. Remove J6 only if a dry, normally closed contact from a fire alarm OR smoke detector system is connected to the Fire Panel [FP] terminals.

JUMPER J7 (DOOR PROP)

INSTALLED: The ExitCheck™ will enter the alarm mode if the door is held open past the request to exit period.

REMOVED: The ExitCheck™ will remain unlocked if the door is held open past the request to exit period. No alarm will sound. The ExitCheck™ will relock and rearm upon closure of the door.

DIP SWITCH SETTINGS

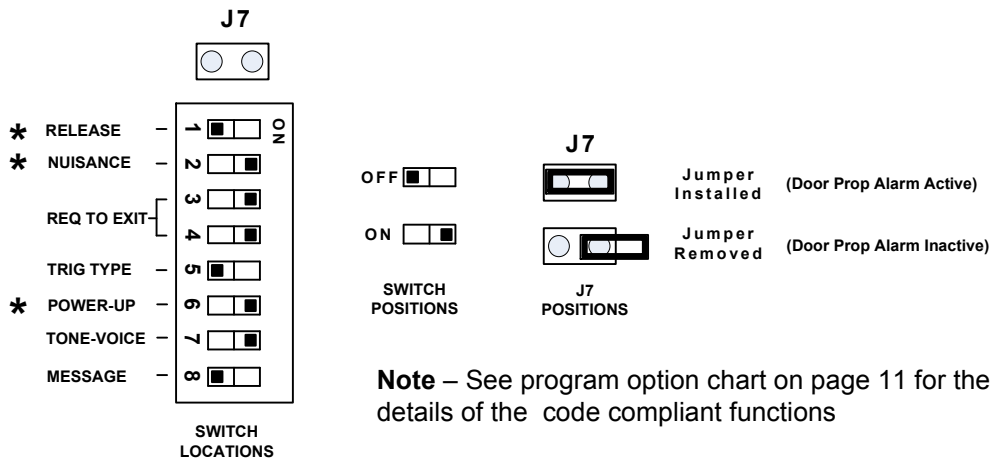

RELEASE TIME* – The Release time can be selectable for 15 or 30 seconds. The Nuisance Delay time period is included in the door release cycle and it will not increase or decrease the “total time to unlock” once the ExitCheck™ is activated.

*** WARNING!**
CONTACT AUTHORITY HAVING JURISDICTION FOR APPROVAL PRIOR TO SELECTING RELEASE TIME OR PWR-UP SETTINGS

NUISANCE DELAY* – The Nuisance delay time feature, intended to avoid accidental triggering, is selectable for 1 or 2 seconds. Releasing the door latch and pushing on the door will activate the internal trigger sensor. Activating the trigger beyond the nuisance delay time will start the irreversible Exit Delay cycle time. The Nuisance Delay time period is included in the lock release cycle and it will not increase or decrease the “total time to unlock” once the ExitCheck™ is activated. Releasing the door before the end of the Nuisance delay time will turn off the warning alarm and reset the ExitCheck™ to secure mode.

REQUEST TO EXIT PERIOD – The Request to Exit (REX) time is selectable for 1, 15, 20, or 30 seconds. The REX time is the period of time the lock will remain “bypassed”, after a remote normally open contact switch is momentarily activated. When activated with an access control system, the REX time cycle begins immediately after the access control open time expires. The ExitCheck™ will automatically relock if the door is opened, and then closed during the REX time cycle.

TRIGGER TYPE – The trigger type is selectable for “REMOTE” or “INTERNAL”. Selecting INTERNAL mode uses the internal trigger sensor to activate the Exit Delay cycle. Selecting REMOTE mode disables the internal trigger. Activation of the Exit Delay cycle is triggered by an external exit device equipped with a normally open contact switch.

POWER-UP STATE* – The power-up option, indicating the state of the ExitCheck™ upon restoration of system power, is can be selected to be “UNLOCKED” or “LOCKED”. In the LOCKED mode, the ExitCheck™ will attempt to reset to secure mode. In the UNLOCKED mode, the ExitCheck™ will remain unlocked and the digital display will indicate two horizontal bars “--”. Turning the reset switch momentarily to the reset position will relock and rearm the door. This feature enables the ExitCheck™ to comply with code requirements in jurisdictions that require manual reset/relock upon loss and restoration of system power.

ALARM TYPE – The alarm type is selectable to “TONE ONLY” or “VOICE”. When secure, the ExitCheck™ digital display will indicate a 15 second delay time. Upon activation of the irreversible Exit Delay cycle, the digital display begins counting down to zero. In VOICE mode, the countdown will be accompanied by a warning beeping tone and verbal exit instructions. When the digital display indicates zero, the ExitCheck™ releases. The speaker output changes to a continuous warning tone and the verbal instruction announces “Exit Now”. In TONE ONLY mode, the countdown will be accompanied by a warning beeping tone only, which changes to a continuous tone once the Exit Delay cycle expires.

MESSAGE TYPE – The message type is selectable to “MSG1” or “MSG2”.

MSG1: (Female Voice) “Exit in 12 seconds, facility staff has been notified...Exit in 5 seconds...exit now...”

MSG2: (Male Voice) “Exit in 12 seconds, security has been alerted...Exit in 5 seconds...exit now...”

Both messages repeat “Exit now” until the lock is reset.

Dip Switch Settings By Model Option Code

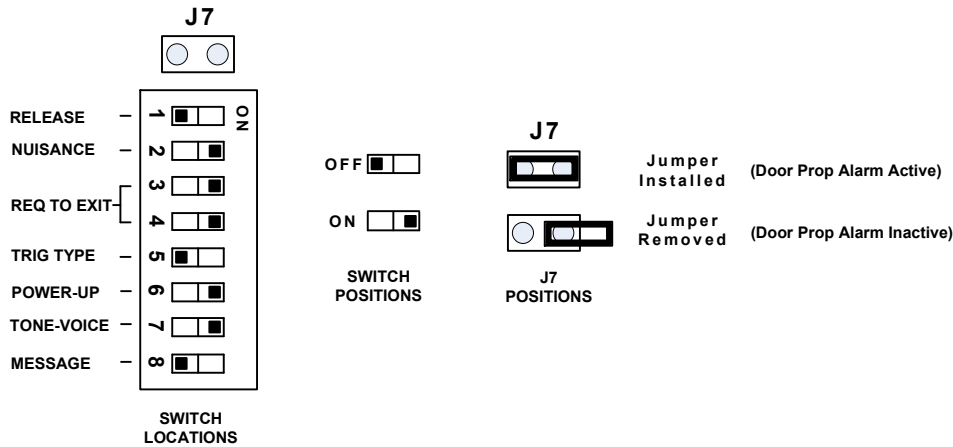

	RELEASE TIME		NUISANCE DELAY		REQUEST TO EXIT PERIOD			TRIGGER TYPE		POWER UP STATE		ALARM TYPE		MESSAGE TYPE	
Option	Switch 1	Switch 2	Switch 3	Switch 4	Switches 3	Switches 4	Switch 5	Switch 6	Switch 7	Switch 8	Switch 9	Switch 10	Switch 11	Switch 12	Switch 13
NA	15 sec	off	1 sec	off	1 sec	ON	ON	Internal	off	Unlocked	off	Tone Only	off	Msg #2	off
	30 sec	ON	2 sec	ON	15 sec	off	off	Remote	ON	Locked	ON	Tone/Voice	ON	Msg #1	ON
All options are selectable					20 sec	ON	off								
					30 sec	off	ON								
ND	15 sec	off	1 sec	off	1 sec	ON	ON	Internal	off	Unlocked	off	Tone Only	off	Msg #2	off
	15 sec	ON	2 sec	ON	15 sec	off	off	Remote	ON	Locked	ON	Tone/Voice	ON	Msg #1	ON
NFPA Compliant					20 sec	ON	off								
					30 sec	off	ON								
NC	15 sec	off	1 sec	off	1 sec	ON	ON	Internal	off	Unlocked	off	Tone Only	off	Msg #2	off
	15 sec	ON	2 sec	ON	15 sec	off	off	Remote	ON	Unlocked	ON	Tone/Voice	ON	Msg #1	ON
NFPA/OSHPD compliant. Power Up Unlocked and Manual Reset are fixed.					20 sec	ON	off								
					30 sec	off	ON								
BD	15 sec	off	0 sec	off	1 sec	ON	ON	Internal	off	Unlocked	off	Tone Only	off	Msg #2	off
	15 sec	ON	1 sec	ON	15 sec	off	off	Remote	ON	Locked	ON	Tone/Voice	ON	Msg #1	ON
BOCA compliant. Automatic alarm reset after 30 continuous seconds of door closure					20 sec	ON	off								
					30 sec	off	ON								
BC	15 sec	off	0 sec	off	1 sec	ON	ON	Internal	off	Unlocked	off	Tone Only	off	Msg #2	off
	15 sec	ON	0 sec	ON	15 sec	off	off	Remote	ON	Locked	ON	Tone/Voice	ON	Msg #1	ON
BOCA/Chicago compliant. 0 sec nuisance. Automatic alarm reset after 30 continuous seconds of door closure					20 sec	ON	off								
					30 sec	off	ON								
NH	30 sec	off	0 sec	off	1 sec	ON	ON	Internal	off	Unlocked	off	Tone Only	off	Msg #2	off
	30 sec	ON	1 sec	ON	15 sec	off	off	Remote	ON	Locked	ON	Tone/Voice	ON	Msg #1	ON
NFPA compliant.					20 sec	ON	off								
					30 sec	off	ON								
BH	30 sec	off	0 sec	off	1 sec	ON	ON	Internal	off	Unlocked	off	Tone Only	off	Msg #2	off
	30 sec	ON	1 sec	ON	15 sec	off	off	Remote	ON	Locked	ON	Tone/Voice	ON	Msg #1	ON
BOCA compliant. Automatic alarm reset after 30 continuous seconds of door closure					20 sec	ON	off								
					30 sec	off	ON								

Lock Adjustment and Operation

STEP 1. After the lock has been mounted to the door and frame per the provided template, feed the wiring through the access hole and out to the controller board. Re-install the lock front cover onto the lock. Ensure that the trigger sensor is aligned with the hole in the cover. The sensor is preset at the factory to slightly project through the cover. **WARNING: DO NOT ATTEMPT TO ADJUST THE TRIGGER SENSOR LENGTH. AS THIS WILL RESULT IN DAMAGE TO THE SENSOR AND VOID THE WARRANTY.**

STEP 2. Make all wiring connections to the lock. Observe the polarity of the input power terminals. The lock senses the power supply voltage and automatically configures itself for 12vdc or 24vdc operation. Correct power supply voltage must be used for proper lock operation. **WARNING: INPUT TERMINALS FOR RESET, REX AND REMOTE TRIGGER MUST ONLY BE CONNECTED TO A NORMALLY OPEN MOMENTARY DRY CONTACT SWITCH (I.E. 918 DIGITAL KEYPAD OR 728 KEY SWITCH). CONNECTION TO A VOLTAGE OR A "WET" OUTPUT MAY DAMAGE THE LOCK AND VOID THE WARRANTY.**

STEP 3. Slowly swing the door closed and visually observe the position of the armature trigger as it approaches the trigger sensor on the lock. If the provided mounting template was used during the lock and armature installation, the trigger & sensor should align with one another both horizontally and vertically. The LED on the back of the trigger sensor will light when the armature trigger is detected. **IMPORTANT: CORRECT OPERATION OF THIS LOCK DEPENDS ON THE TRIGGER SENSOR BEING ABLE TO DETECT THE ARMATURE TRIGGER WHEN THE DOOR IS CLOSED. A PROXIMITY ADJUSTMENT CAN BE MADE TO THE TRIGGER FOR FINE TUNING. THIS IS EXPLAINED IN STEP 4.**

STEP 4. The small black spot located on the locks front access cover facing the door is the trigger sensor. The TRIGGER SENSOR LED as well as the DIGITAL DISPLAY are beneficial in the testing process.

the TRIGGER SENSOR LED located on the back of the sensor can be used to check the sensors operation and verify proper alignment and adjustment of the circular TRIGGER located on the armature assembly. The trigger sensor LED can be viewed through the terminal block side of the lock with the cover removed. You can find this near the speaker.

The DIGITAL DISPLAY can be used for diagnostics when the lock is in bypass mode. It uses the TRIGGER SENSOR to sense door position so can also be used to check TRIGGER SENSOR operation.

- "Double Dash Marks" (--) indicate that the TRIGGER SENSOR sees the TRIGGER and that the door is closed.
- "Six Dash Marks" (::) indicate that the TRIGGER SENSOR does **not** see the TRIGGER. The door is either open or the trigger is improperly adjusted.

Set the lock to BYPASS mode by turning the built in key on the lock counterclockwise. With the lock in the bypass mode, swing the door open. The TRIGGER SENSOR LED should be off and the digital display should show "Six Dash Marks". Prop your door open, place and hold a metal object (such as a coin) against the TRIGGER SENSOR on the face of the and verify that the TRIGGER SENSOR LED turns ON and that the DIGITAL DISPLAY changes to "Double Dash Marks"

Remove the metal object and verify that the TRIGGER SENSOR LED turns OFF and the DIGITAL DISPLAY changes back to "Six Dash Marks". This verifies that the trigger sensor is working.

Close the door and verify that the TRIGGER SENSOR LED turns ON. If the LED does not turn ON and the DIGITAL DISPLAY does not change, adjust the TRIGGER on the armature assembly by turning the allen head screw in the center of the TRIGGER counterclockwise which will extend the trigger outward toward the lock face. Proper adjustment will allow the TRIGGER to touch the face of the TRIGGER SENSOR and be slightly depressed with the door fully closed.

Reset the lock by turning the built in key switch momentarily clockwise. The lock should lock and the digital display should show the delay time. Now, push the door. With slight door movement (1/8" to 1/4") the delay process should start with the display counting down and the alarm sounding. If the delay process does not start once the door has moved, the circular target has been adjusted too far out and needs to be adjusted back in slightly. A properly adjusted target will pull away from the face of the sensor with 1/8" to 1/4" of door movement and start the delay process.

STEP 5. Activation of the 1511S can be made by door movement or an external trigger. When using the door movement method, activation is achieved through the way the armature hardware is designed. When someone unlatches the door and applies up to 15 lbs. pressure, the lock will hold onto the armature while simultaneously letting the door & trigger armature move away from the lock & trigger sensor. Sensitivity in the detection of the trigger movement can be adjusted for optimum sensitivity & performance. This adjustment can be made as indicated in step 4. The center of the trigger or "target" is spring loaded and can be screwed in and out of the armature thus either decreasing or increasing the space between itself and the sensor. The "spring" feature of the target is to prevent damage from direct contact with the trigger sensor. Depending on the accuracy of the alignment, the trigger does not have to physically touch the sensor to operate correctly.

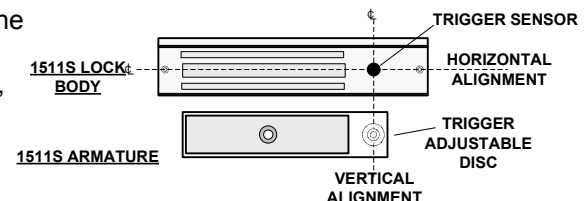

Systems Applications Reference

Activation by applying pressure to doors with latching hardware:

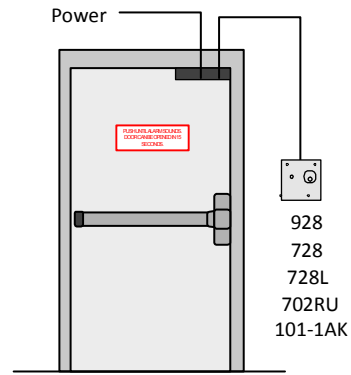

Wall Mount Reset Station (Optional)

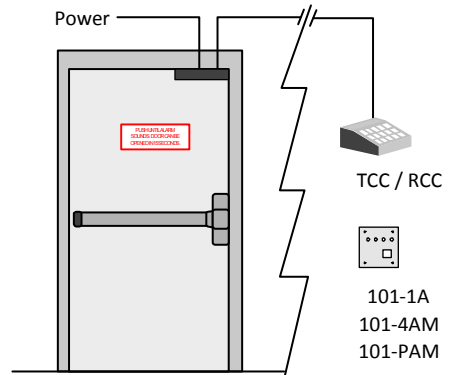

Remote Annunciators and Control Panels (Optional)

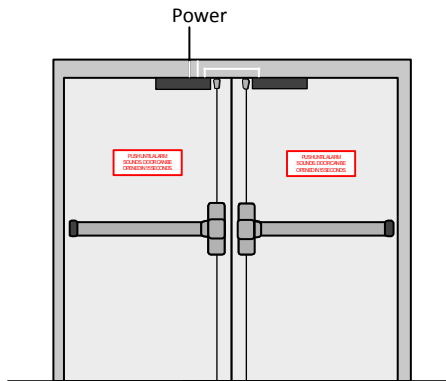

A pair of doors requires the 1511T
Pushing either door triggers
the delayed release of both doors.

Activation by a remote trigger for doors with or without latching hardware:

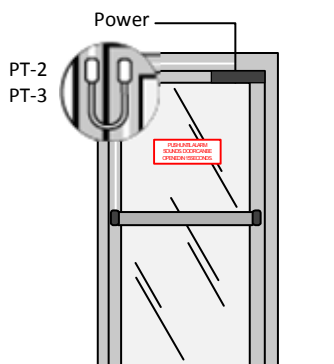

Sense Bar Trigger Non-Latching
PSB560, MSB550

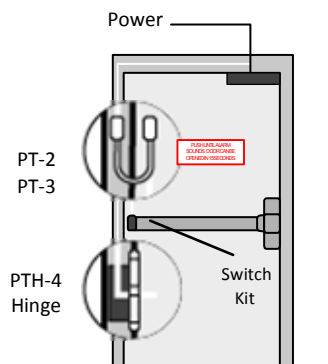

Latching Exit Device with
Built-in Switch Kit Trigger

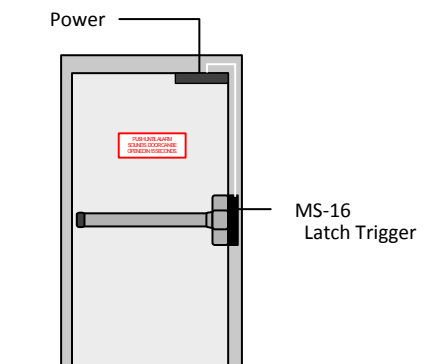

Latch Monitoring Strike Trigger
For Mortise Exit Devices