

**FOR DEVICES SOLD  
PRIOR TO  
4-14-14**

# 33/3549A CS 33/3549A

**VON DUPRIN®**

Installation Instructions

This instruction covers new installation of the 33/3549A concealed vertical device for aluminum and hollow metal doors.

Also covered is the CS 33/3549A retrofit cabling system for converting 33/3547A Series to 33/3549A Series (compatible with models 33/3547A, 33/3547A-F, 33/3547A-LBR, and 33/3547A-F-LBR).

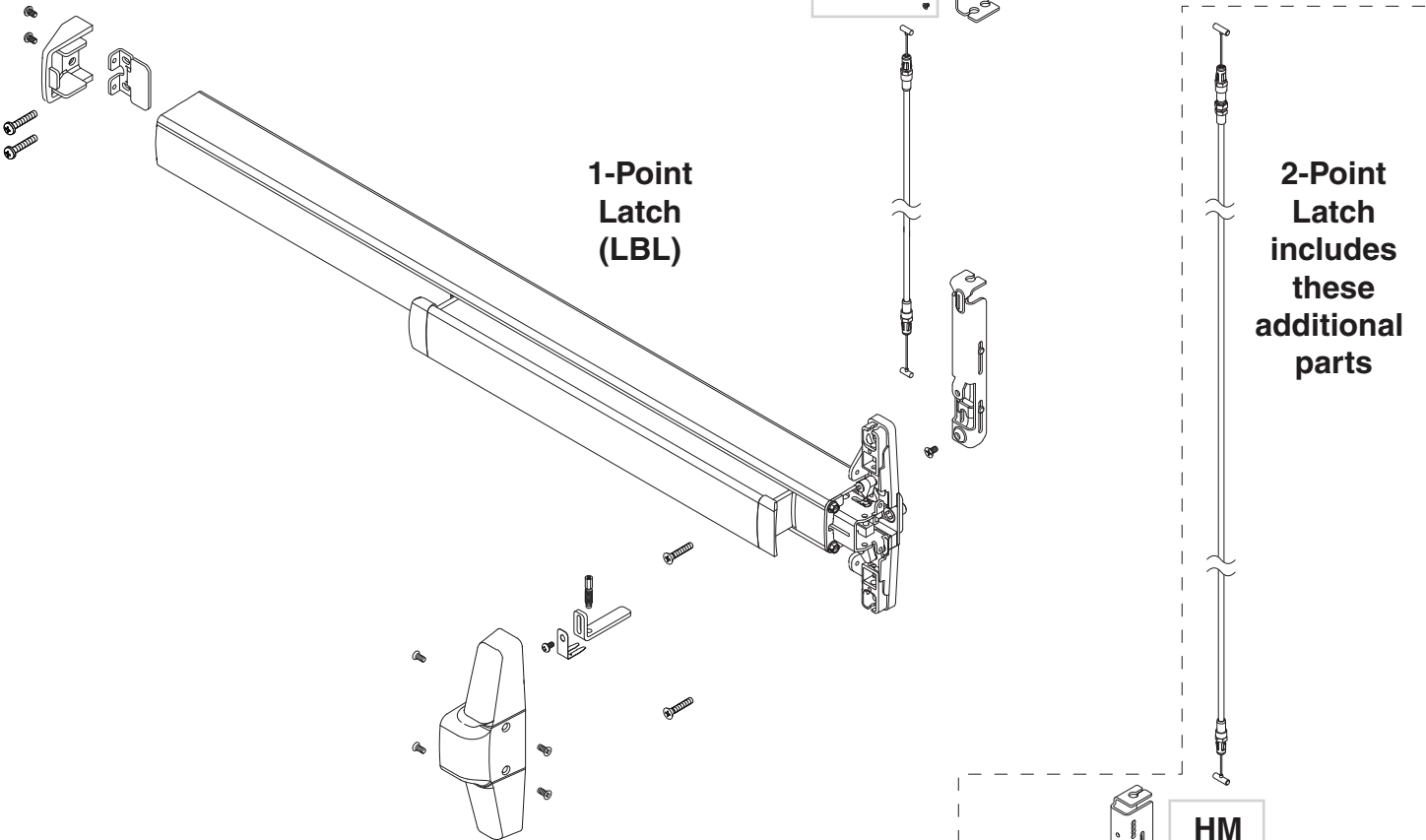

- AL** = for Aluminum Door applications
- HM** = for Hollow Metal Door applications
- RF** = for Hollow Metal Door Retrofit applications

**Customer Service**

1-877-671-7011

[www.allegion.com/us](http://www.allegion.com/us)



© Allegion 2015  
Printed in U.S.A.  
110338 Rev. 10/15-b

# 1 Identify Cables and Locations.

(if not preinstalled in door)

**NOTE:** For retrofit installations, begin at Step 5.

For easy identification, each cable is labeled with part number and location.

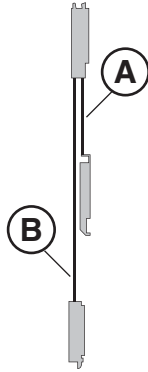

CABLE IDENTIFICATION (STANDARD SIZES)				
Door Opening Height	HOLLOW METAL AND WIDE STILE ALUMINUM DOORS		NARROW STILE ALUMINUM DOORS	
	A Top Cable (Red)	B Bottom Cable (White)	A Top Cable (Red)	B Bottom Cable (White)
6' 8"	23925795	23926207	23925803	23926215
7' 0"	23925761	23926173	23925761	23926173
8' 0"	23925647	23926058	23925647	23926058
9' 0"	23925522	23925936	23925522	23925936
10' 0"	23925407	23925811	23925407	23925811

# 2 Install Cable(s).

a. Position red cable end to clip on center slide

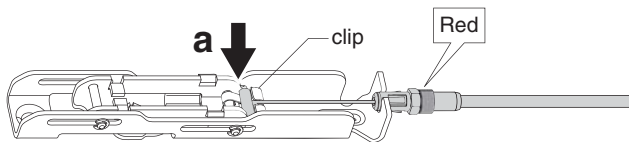

b. Pull cable into clip to snap it into place

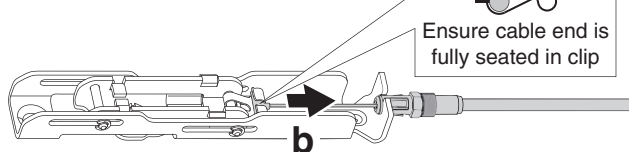

c. Push cable snap against center slide to secure cable

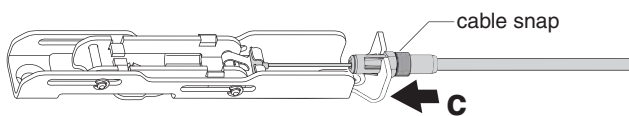

d. In the same way, install opposite end of red cable to top latch in the position marked red

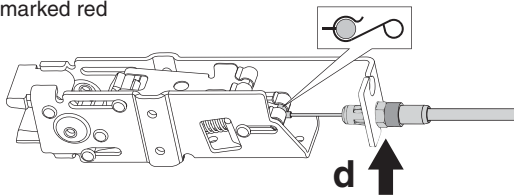

## For 2-Point Latch Only

e. There is an adjuster on one end of the white cable. Install this end to the remaining top latch position (marked as white)

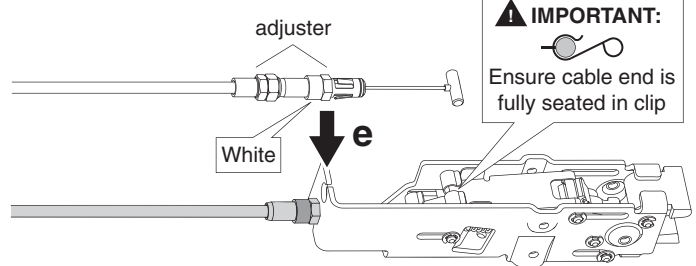

f. Install opposite end of white cable to bottom latch

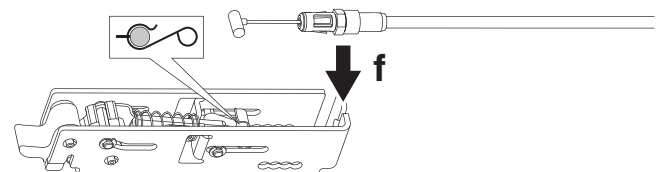

# CABLE REMOVAL

A cable removal tool has been provided. Slot in tool fits over cable, holding tabs down. Pull on cable snap to loosen cable for removal.

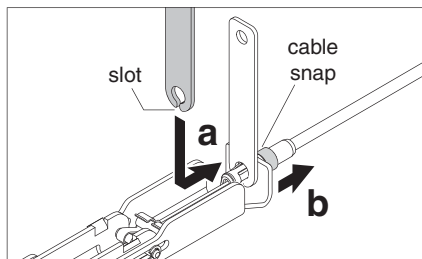
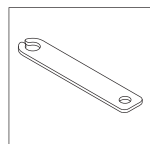

### 3 Determine if Bottom Latch Retraction Adjustment is Necessary.

#### For 2-Point Latch Only

- a. Flex the cable into an L-shape as shown to simulate the installed condition of the latches.

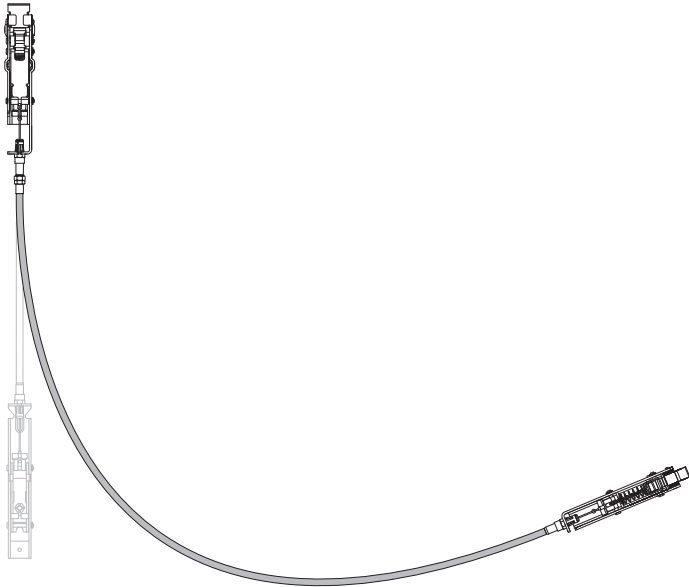

- b. To determine whether an adjustment is required, actuate the top latch to the hold-open position by pressing down on the connecting rod. Bottom latch should retract to within  $\frac{1}{16}$ " of flush. If it does not, an adjustment is necessary.

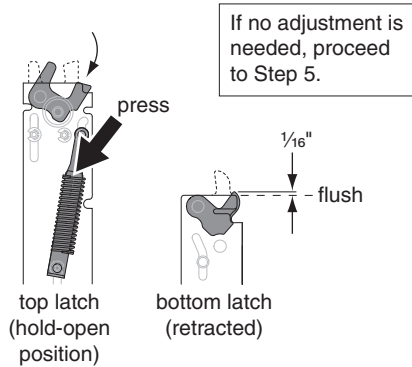

### 4 Adjust Bottom Latch Retraction (if necessary). For 2-Point Latch Only

- ! NOTE:** Adjustment must be made while the top latch is in the hold-open position, with cable flexed into an L-shape to simulate the installed condition of the latches.



These (3) hex components are used to make the adjustment.

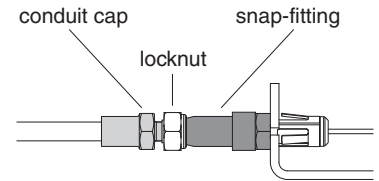

- a. While holding the snap-fitting with a  $\frac{3}{8}$ " wrench, use a 10mm wrench to break loose the lock nut.

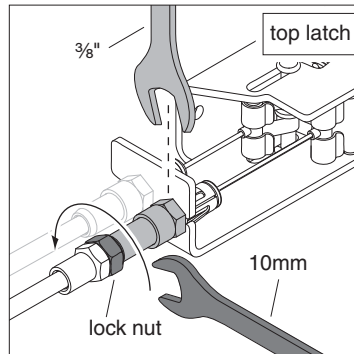

- c. While holding the conduit cap with a  $\frac{3}{8}$ " wrench, use a 10mm wrench to turn the locknut in a clockwise direction to close the gap between the lock nut and snap-fitting. Stop when the gap is closed and the snap-fitting begins to turn with the locknut.

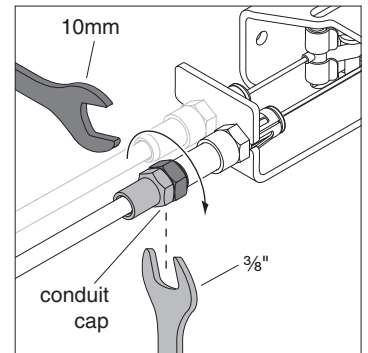

- b. While holding the lock nut in place, rotate the barrel of the snap-fitting clockwise by hand until the bottom latch is retracted to within  $\frac{1}{16}$ " of flush.

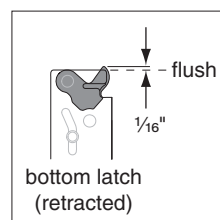
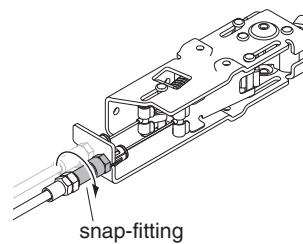

- d. While holding the snap-fitting with a  $\frac{3}{8}$ " wrench, continue to tighten the locknut until it is secure.

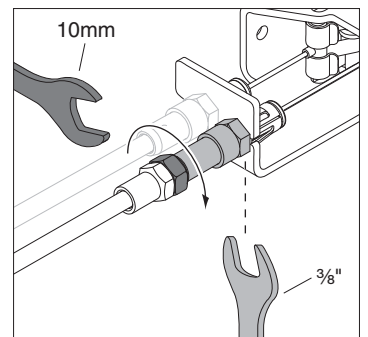

## 5 If Retrofit Installation

- Remove device from existing door.
- Remove and discard existing door.
- Remove and discard existing strikes.

## 6 With Door Laying Flat, Draw Horizontal and Vertical Device Center Lines (C).

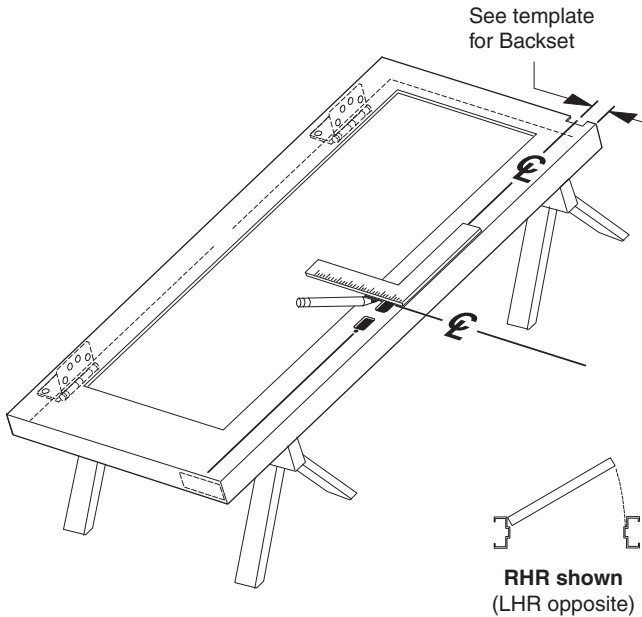

**NOTE:** Centerlines are predetermined by cutout. If no cutout exists, refer to templates at the back of this instruction to determine centerlines.

## 7 Align Paper Template to Mark and Prepare Door, if Required.

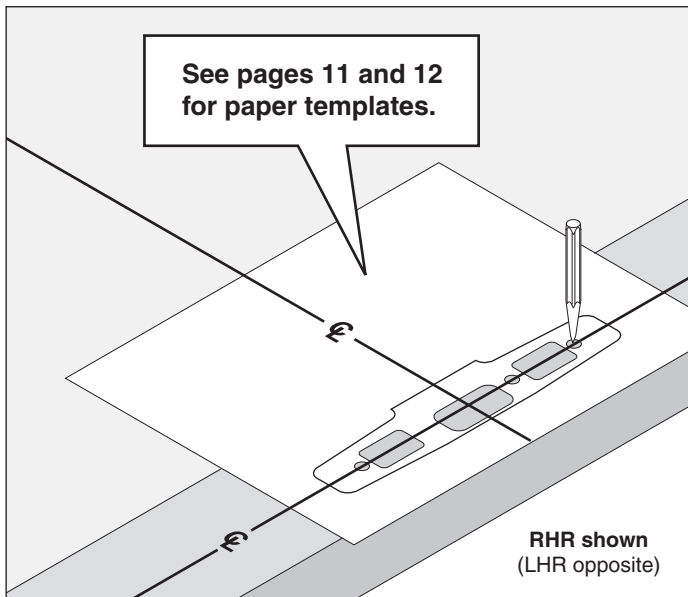

## 8 Assemble Latch Mounting Brackets. Hollow Metal

Top

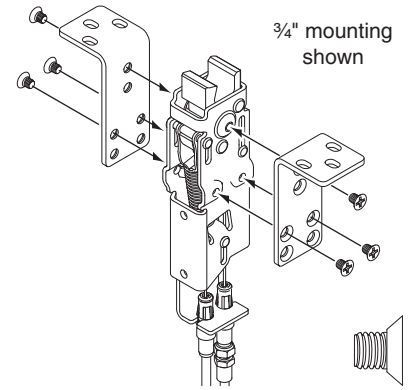
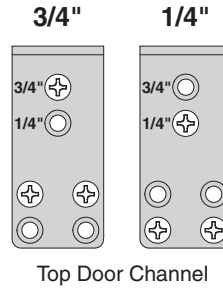

Bottom

For 2-Point Latch Only

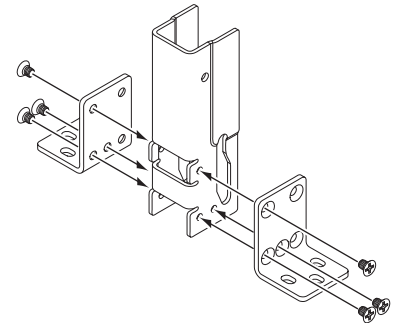

## 9 Prepare Access Hole for Bottom Latch Adjustment Pin.

Hollow Metal For 2-Point Latch Only

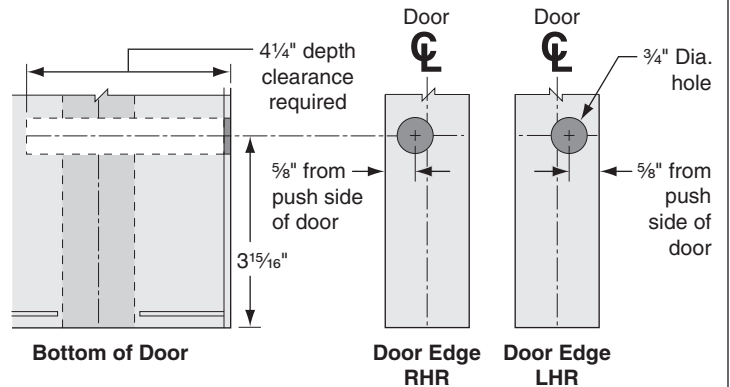

**10** If Necessary, Prepare Door for Top Strike Cutout.

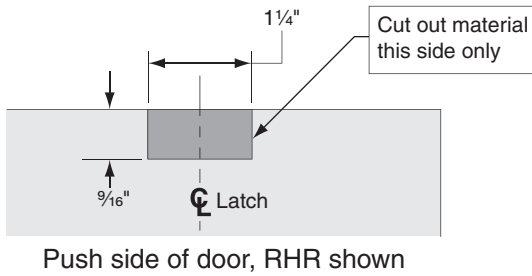

**13** If Using 360/386/388 Thru-Bolting Trim, Remove Center Slide Mounting Nut.

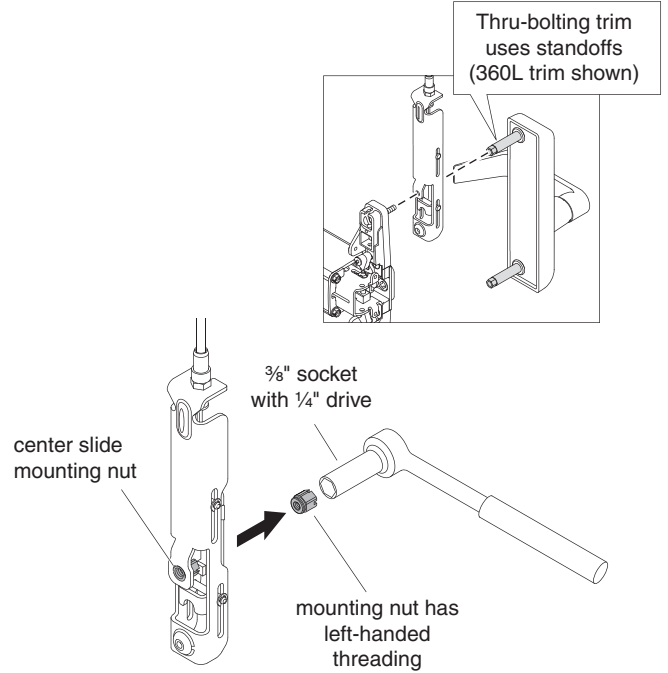

**11** Prepare Top of Door for Latch Mounting.  
**Aluminum**

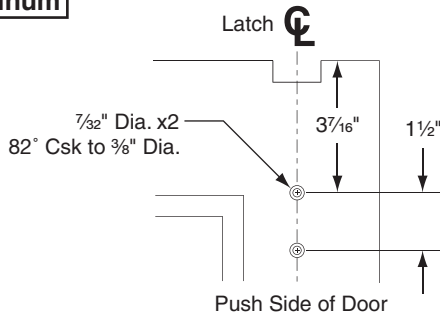

**12** Prepare Bottom of Door for Latch Mounting.  
**Aluminum For 2-Point Latch Only**

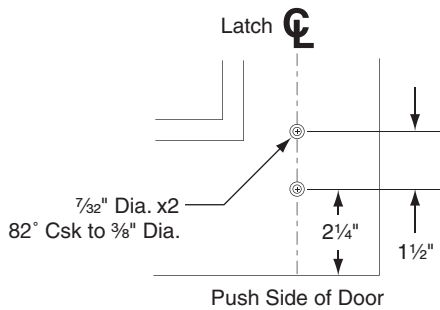

**14** Slide Latch and Center Slide Assembly thru Door.

**NOTE:** Confirm top latch (and bottom latch, if applicable) is in correct orientation before proceeding.

**NOTE:** It is normal for the cable to bend inside the door, forcing the latch outward.

**1-Point Latch (LBL)**

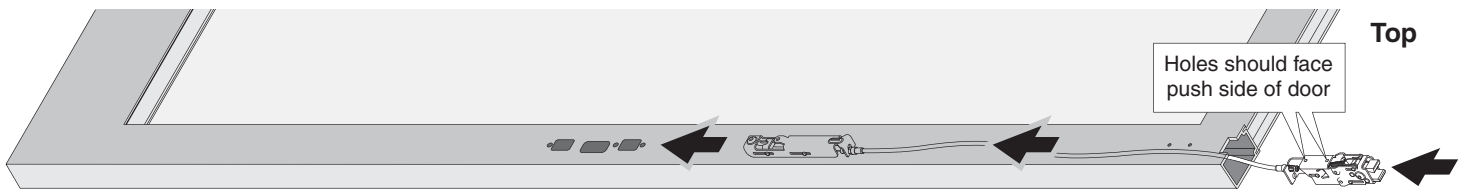

**2-Point Latch**

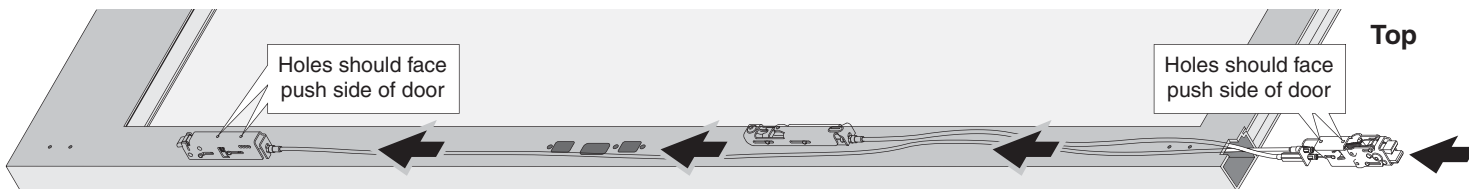

Aluminum Door application shown

**15** Secure Center Slide to Door.

Secure center slide to door by lightly tightening lower screw

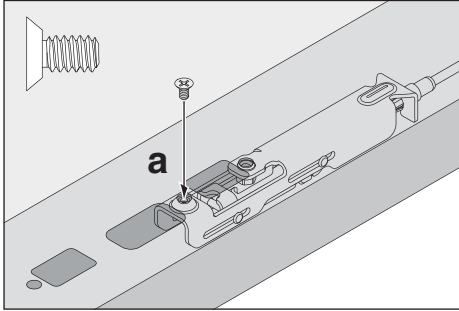

Align upper hole visually

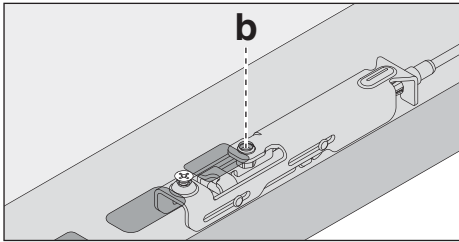

Insert small screwdriver into upper hole to prevent center slide from rotating

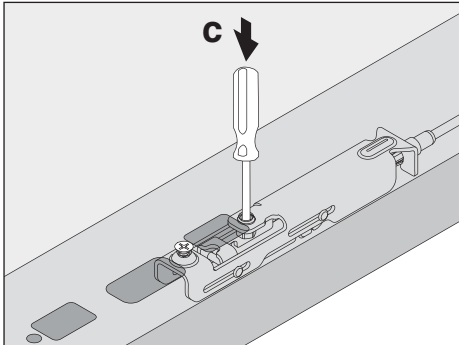

Fully tighten lower screw

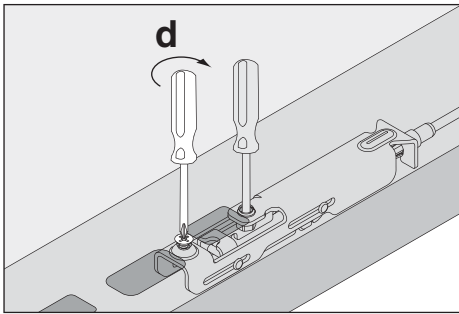

**16** Align Bottom Latch and Install Mounting Screws.  
**Aluminum For 2-Point Latch Only**

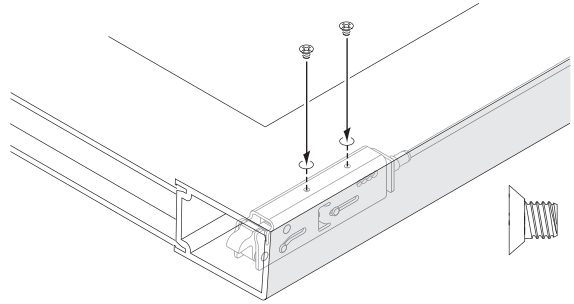

**17** Secure Top Latch with 2 Screws.  
**Aluminum**

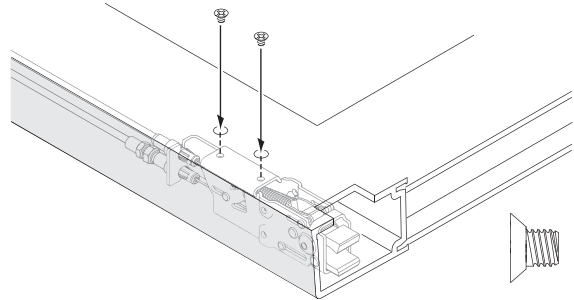

**18** Install Bottom Latch Mounting Bracket Assembly.  
**Hollow Metal For 2-Point Latch Only**

**NOTE:** Confirm correct orientation of assembly before proceeding. Open side of housing should face pull side of door.

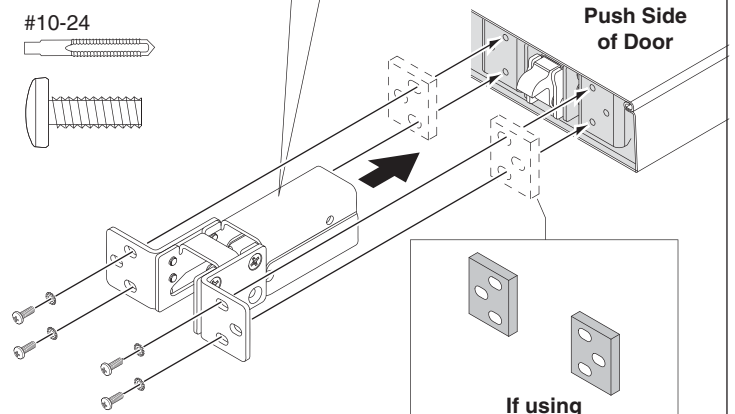
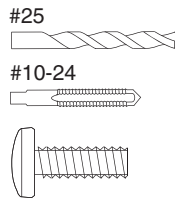

**NOTE:** Use 2 screws per bracket (center hole not used for this application).

**If using 3/4" undercut door**  
spacer blocks (2) are required  
Spacer Block Kit (24231516) purchased separately

**19** Insert Latch Adjustment Pin to Hold Bottom Latch in Place.

**Hollow Metal For 2-Point Latch Only**

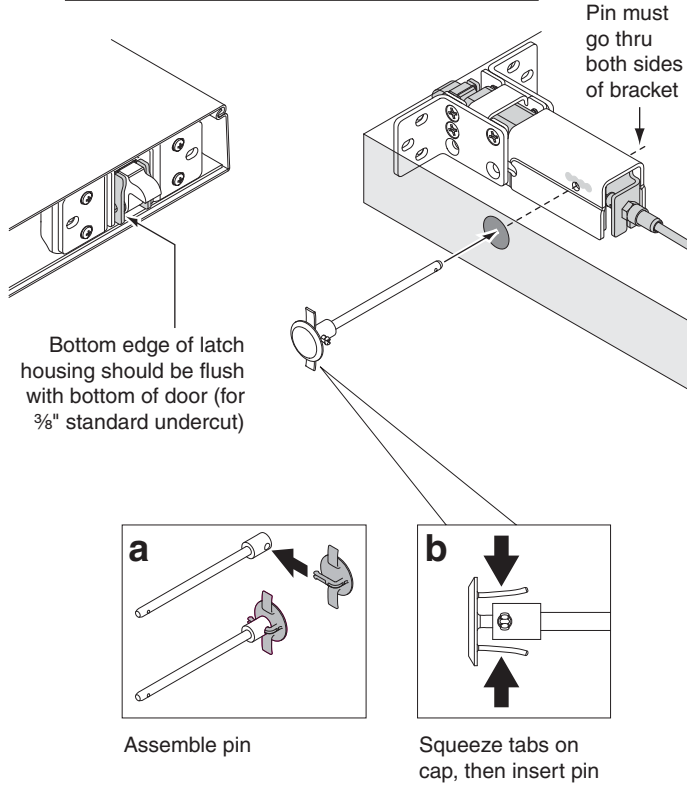

**22** If Necessary, Cut Device.

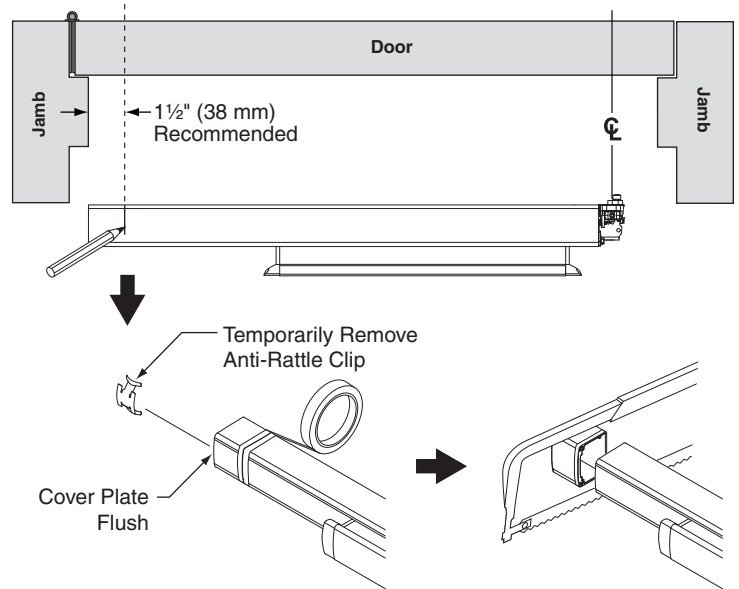

**23** Attach Center Case to Door.

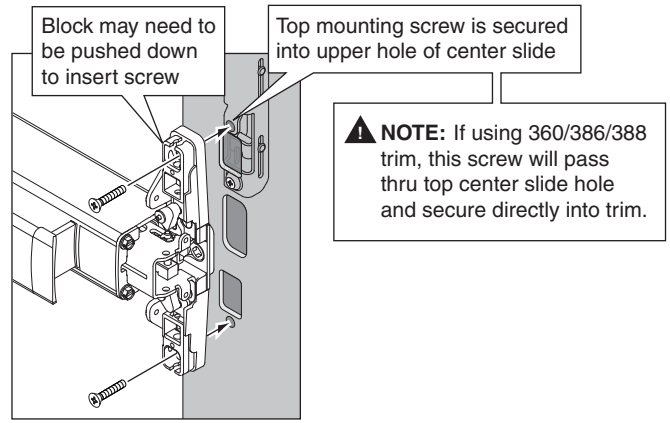

**20** Secure Top Latch Mounting Bracket.

**Hollow Metal**

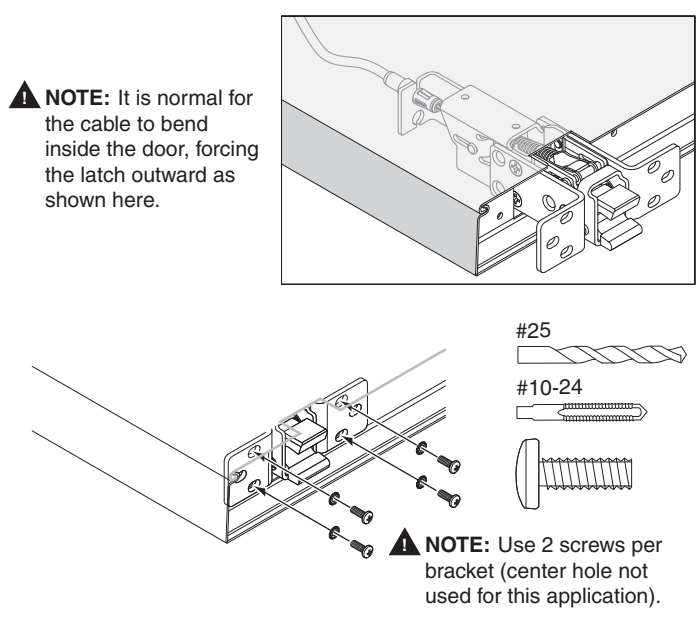

**21** Hang Door on Frame.

**CAUTION:** For 2-point latches, bottom latch cannot be in locked position while hanging door on frame. Latch must be retracted.

**Thru-bolting Trim**

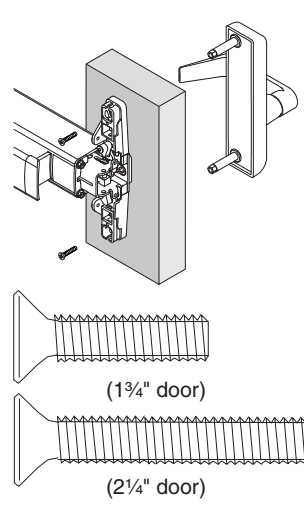

**Sex Bolt**

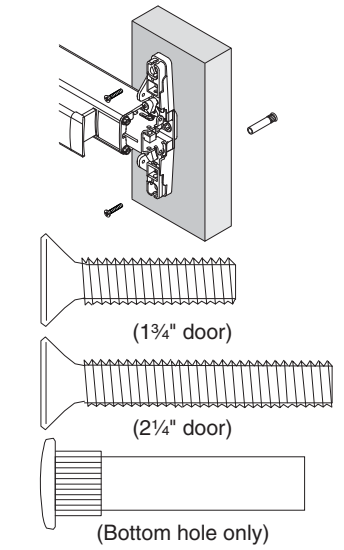

**24** Mark and Prepare 2 Holes.

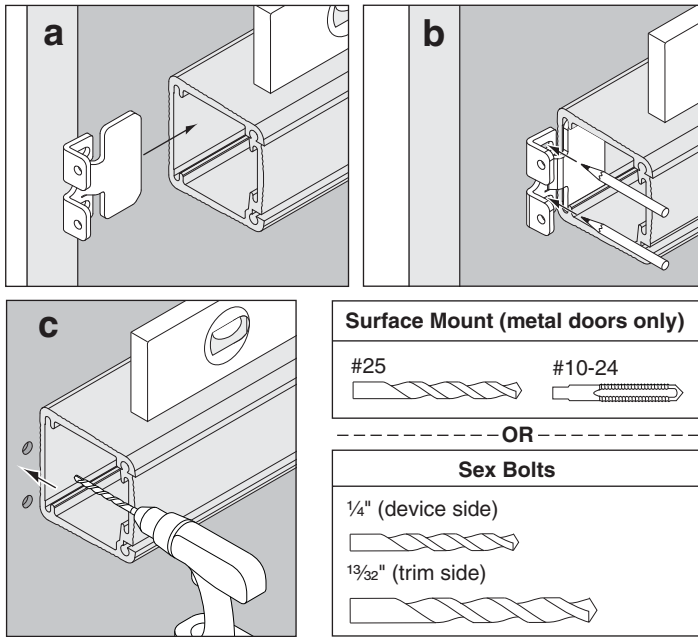

**25** Install End Cap Bracket and End Cap.

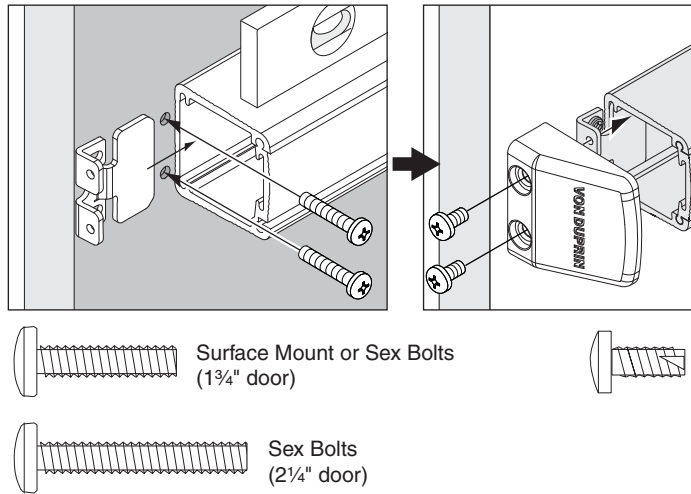

**26** If New Installation, Prepare Door Frame for Top Strike.

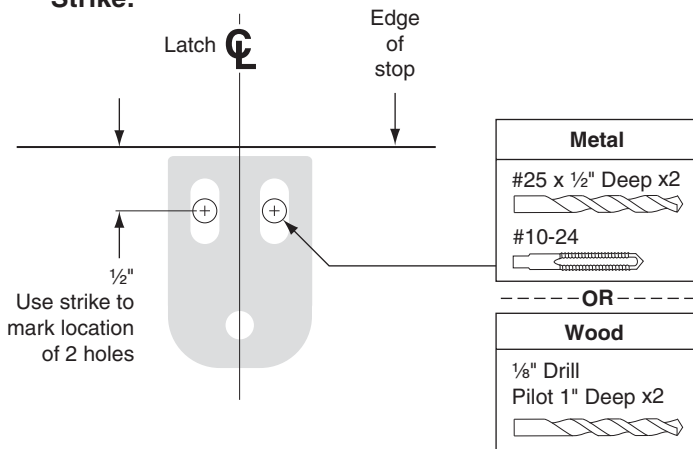

**27** If Retrofit Installation, Install Steel Cover Plate to Cover Existing 338 Strike Opening in Accordance with the Frame Manufacturer's Fire Listing.

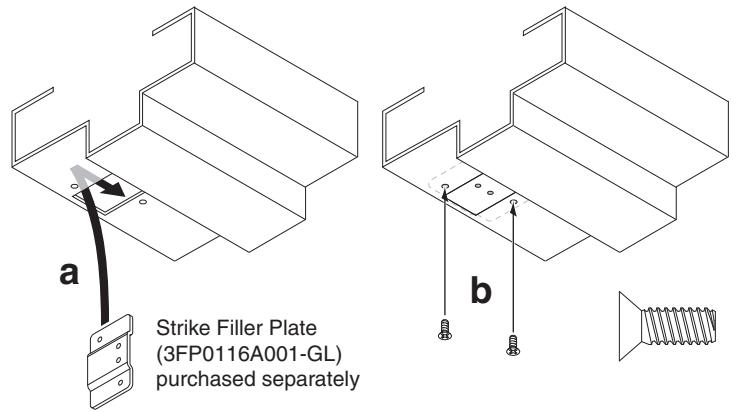

**28** Install 2 Top Strike Screws Using the Slot Features on the Strike.

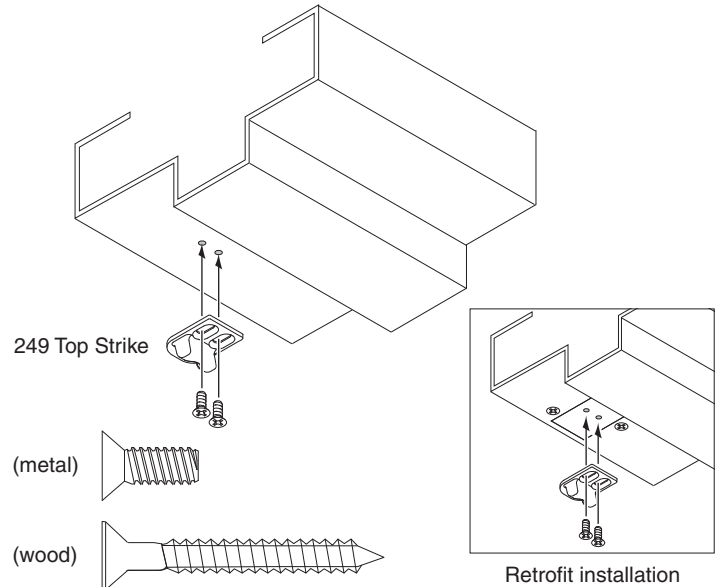

**29** Prepare Floor for Bottom Strike. **Hollow Metal For 2-Point Latch Only**

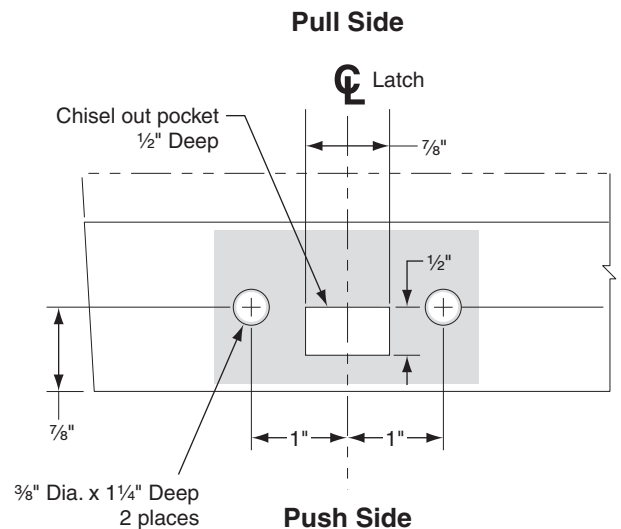



### 30 Install Bottom Strike.

**Hollow Metal For 2-Point Latch Only**

Clear holes of debris, then drop in anchors (slotted end first)

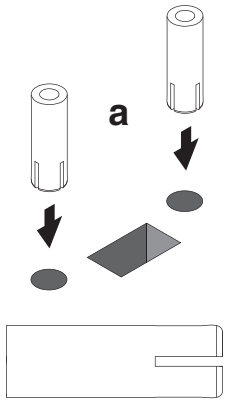

Secure the anchors using a hammer and punch

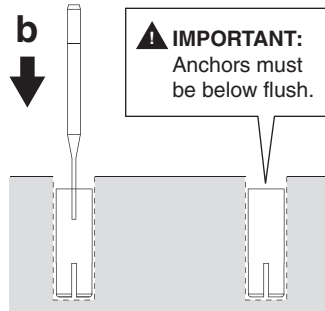

Install strike plate and secure with 2 screws

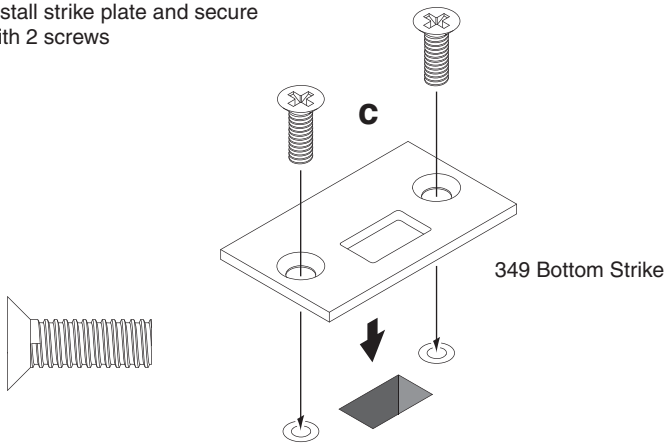

### 31 Prepare Threshold.

**Aluminum For 2-Point Latch Only**

- After closing door with bottom latch installed, mark the location the bottom latch bolt is contacting the threshold.
- Drill a 3/4" diameter hole in the threshold.

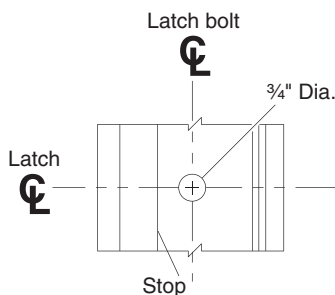

### 32 Install Lift Finger and Retainer Clip.

**NOTE:** The lift finger installation and adjustment must be performed while the latches are in the extended (latched) position.

Slide L-shaped lift finger thru block in device center case and then into center slide

**For 2-Point Latch Only**

Push cable to the side so it does not interfere with lift finger.

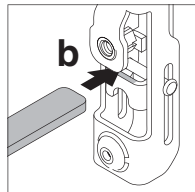

Lift finger must insert into center slide here

Insert adjustment screw through top slot and rotate with screwdriver to raise lift finger until it is snug against block

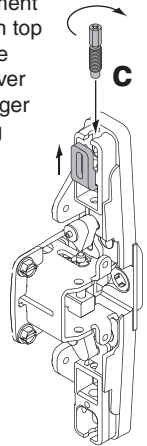

Install retainer clip against lift finger, snapping it into the slot of the adjustment screw

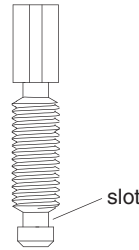

Secure lift finger and retainer clip with screw

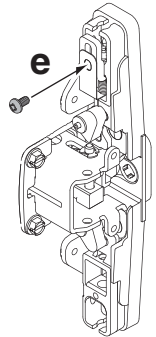

### 33 Adjust Lift Finger.

**NOTE:** Lift finger adjustment must be performed while the latches are in the extended (latched) position.

Loosen retainer clip screw

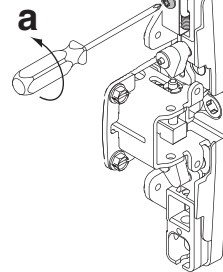

Loosen adjustment screw until the lift finger drops and you feel contact with the center slide

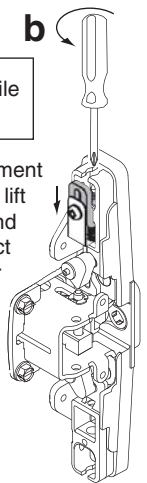

Tighten retainer clip screw

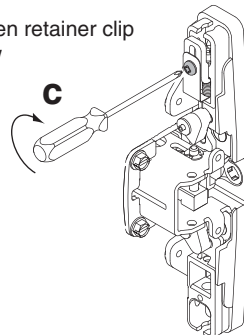

### 34 Perform Functional Test of Door.

- Depress pushbar. Door should begin to open when pushbar is nearly fully depressed. If necessary, refer to Step 33 to readjust lift finger.
- With door closed, top latch should be secure.

#### For 2-Point Latch Only

- With door closed, bottom latch should be secure.
- Confirm that bottom latch does not drag against floor when door is opened.

#### Hollow Metal For 2-Point Latch Only

If this occurs, remove latch adjustment pin and raise latch, then reinsert pin in next notch.

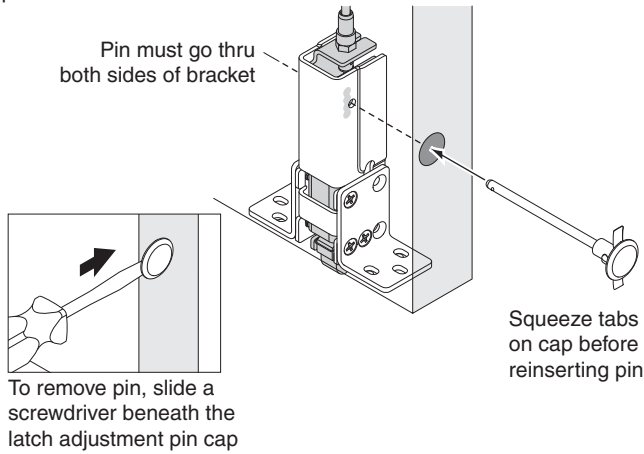

### 35 Adjust Top Strike as Necessary, then Install the Third Strike Screw to Fix the Strike Position.

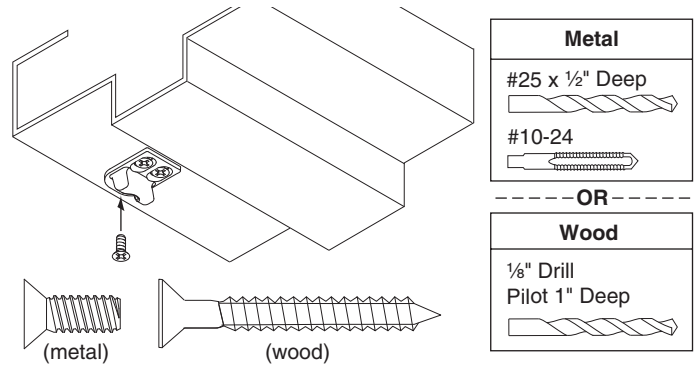

### 36 Install Center Case Cover.

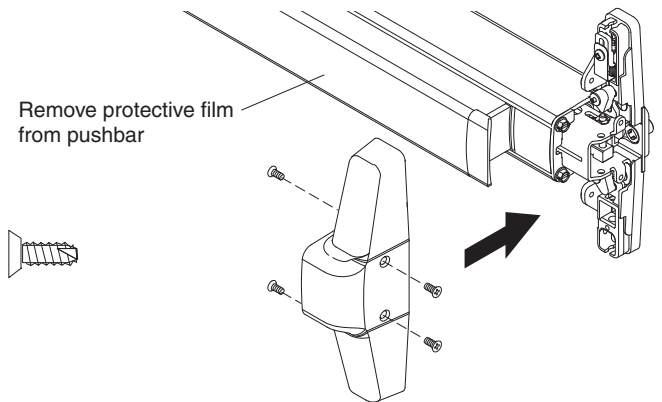

## OPTIONAL EQUIPMENT

### CD (CYLINDER DOGGING)

- Remove mortise cylinder cam and reinstall in reverse (Figure 1).
- Insert key and rotate cam to install the cylinder to the cover plate (Figure 2).
- Remove key to slide cover plate in position in the mechanism case.

#### CD function conversion

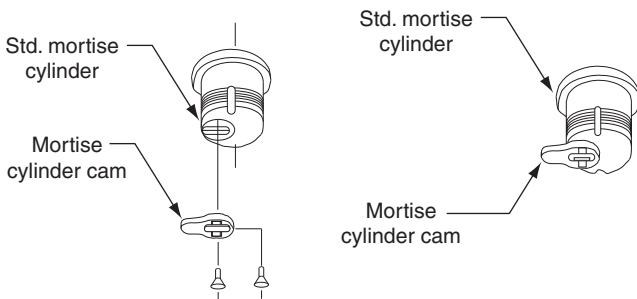

Figure 1

#### Dogging procedure

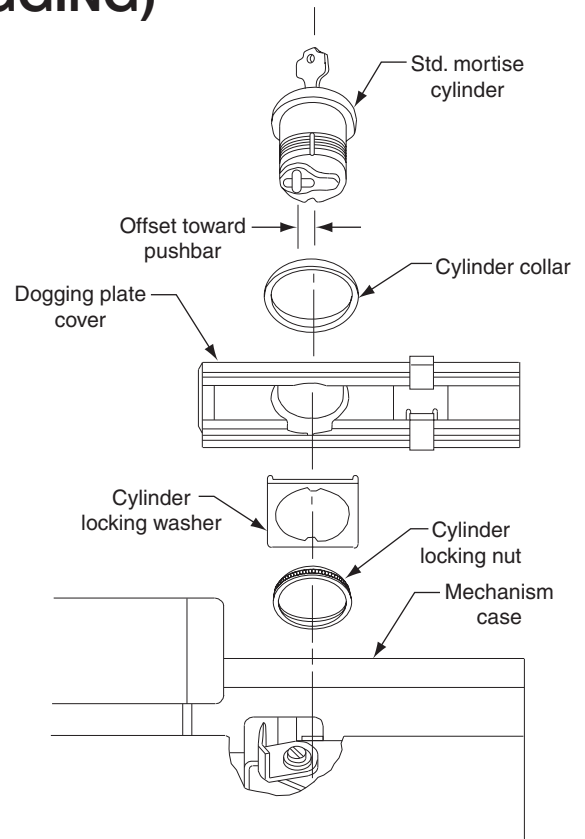
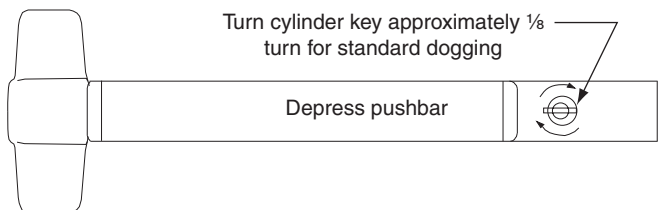

Figure 2

# ALUMINUM AND HOLLOW METAL DOORS - RHR

## 33/3549A Device Template

☒ Device

RHR

B = backset

A = stile width

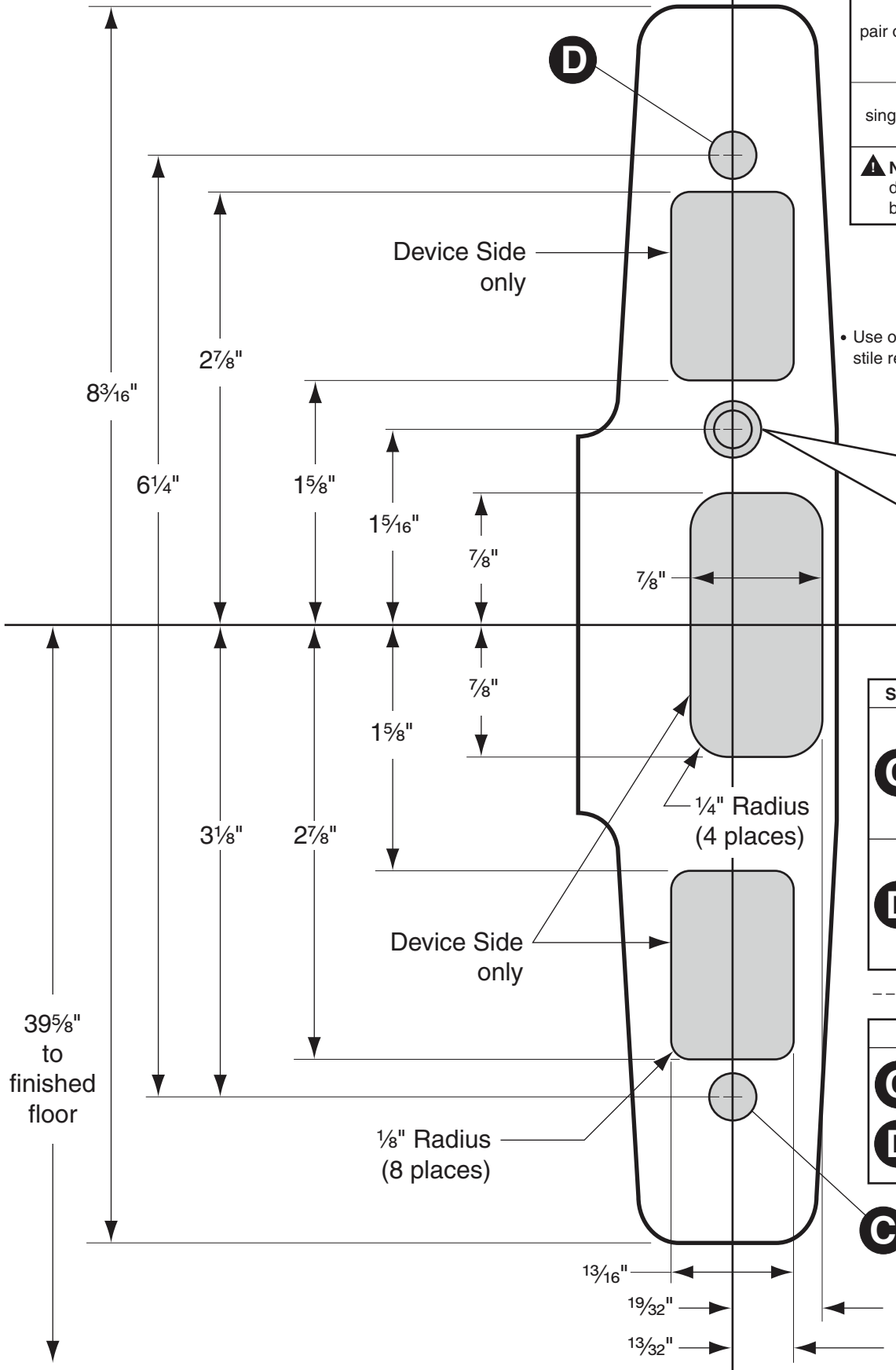

33/3549A		
Installation	A	B
pair of doors	2 1/8" to 2 3/4"	1 3/16"
	2 3/4" to 3 3/4"	1 1/2"
	3 3/4" to 5"	1 7/8"
single door	5" to flush	2 1/2"
	2 1/2" to 3 3/4"	1 1/2"
	3 3/4" to 5"	1 7/8"
5" to flush	2 1/2"	

**NOTE:** Consult aluminum door manufacturer to confirm backset compatibility.

33/3549A-F	
A	B
3 5/8" Min.	2 3/4"

• Use of outside trim may alter minimum stile requirement. See trim template.

Aluminum Door
1/4" Dia. (Device Side only) 82° Csk to 7/16" Dia.
----- OR -----
Hollow Metal Door
1/4" Dia. (Device Side only) 82° Csk to 3/8" Dia.

☒ Device

Sex Bolt (for bottom hole only)	
<b>C</b>	5/16" (device side) 1 3/32" (trim side)
<b>D</b>	5/16" (device side) (Screw will tighten directly into center slide)

Thru-Bolting Trim	
<b>C</b>	5/16" (device side)
<b>D</b>	1/2" (trim side)

# LHR

# Device $\mathcal{C}$

# ALUMINUM AND HOLLOW METAL DOORS - LHR

## 33/3549A Device Template

**B = backset**

**A = stile width**

33/3549A		
Installation	A	B
pair of doors	2 1/8" to 2 3/4"	1 3/16"
	2 3/4" to 3 3/4"	1 1/2"
	3 3/4" to 5"	1 7/8"
single door	5" to flush	2 1/2"
	2 1/2" to 3 3/4"	1 1/2"
	3 3/4" to 5"	1 7/8"
	5" to flush	2 1/2"

**NOTE:** Consult aluminum door manufacturer to confirm backset compatibility.

33/3549A-F	
A	B
3 5/8" Min.	2 3/4"

• Use of outside trim may alter minimum stile requirement. See trim template.

Aluminum Door
1/4" Dia. (Device Side only) 82° Csk to 7/16" Dia.
OR
Hollow Metal Door
1/4" Dia. (Device Side only) 82° Csk to 3/8" Dia.

# $\mathcal{C}$ Device

Sex Bolt (for bottom hole only)	
<b>C</b>	5/16" (device side)
	1 3/32" (trim side)
<b>D</b>	5/16" (device side)
	(Screw will tighten directly into center slide)

OR

Thru-Bolting Trim	
<b>C</b>	5/16" (device side)
<b>D</b>	1/2" (trim side)

