

FALCON®

T Series

Grade 1, cylindrical lock

Overview

Falcon is focused on offering a solid product and that is why the T Series lock is constructed with a compression spring that far exceeds ANSI/BHMA cycle test requirements. Unlike typical torsion springs that can break at the bend points, the T Series spring provides the most robust lever support for years of reliable performance. Perfect for high-use applications the T Series lock delivers the Falcon promise of providing a solid product with solid performance at a solid price.

Falcon fits - The most versatile lockset in the business

- Fits most competitors' conventional key systems
- Fits all competitors' interchangeable cores
- Pressure Release® lever rotation standard. Prevents damage to internal lock components when subjected to excessive force.
- Ideal for both new construction and retrofit
- Designed for high-use applications such as multi-family, retail, office, institutional and government/military



The most robust lever support

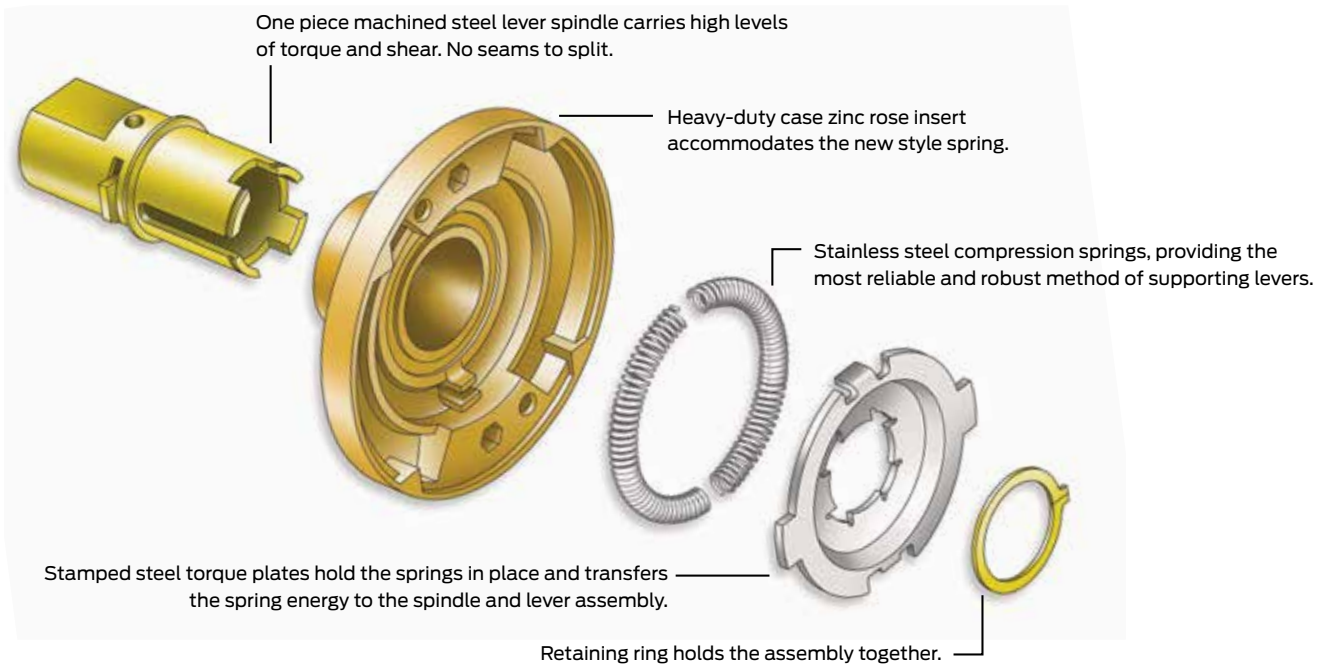

Designed to work hard

T Series levers are available in three designs. Additional options such as abrasive coating and lead lining are available on all T Series levers to cover a variety of application requirements.



Avalon



Dane



Quantum

Available finishes



605
Bright brass



606
Satin brass



613
Oil rubbed bronze



625
Bright chrome



626
Satin chrome

About Allegion

Allegion (NYSE: ALLE) creates peace of mind by pioneering safety and security. As a \$2 billion provider of security solutions for homes and businesses, Allegion employs more than 8,000 people and sells products in more than 120 countries across the world. Allegion comprises 27 global brands, including strategic brands CISA®, Interflex®, LCN®, Schlage® and Von Duprin®. For more, visit www.allegion.com