



40 SERIES MAGNETIC LOCK

INSTALLATION INSTRUCTIONS & CUT-OUT TEMPLATE

The 40 Series magnet is powered by 12 or 24VDC only. Schlage offers several power supplies which can be used to power magnetic locks. Magnetic locks are usually controlled by an access control reader (card, prox, etc.) and an egress device such as an exit device with a switch, pushbutton and/or motion detector. In most cases it is required that activation of building's fire alarm system cause all magnetic locks to unlock. Consult local authority having jurisdiction regarding system requirements for local life safety and electrical codes.

1) Place template on door and frame as shown. Leave room if required for existing door hardware such as vertical rod panic hardware, etc. Drill required holes.

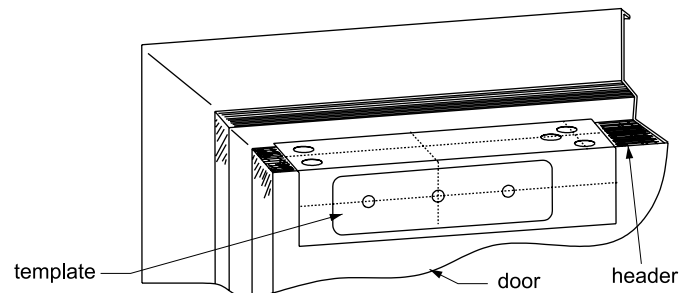

2) Install armature plate assembly. Note that armature plate assembly must pivot about the mounting bolt. This is to allow the magnet and armature to mate when the door is closed. If the armature does not pivot, check to see that there is no binding in the 1/2" armature guide holes and that the hardware is installed correctly.

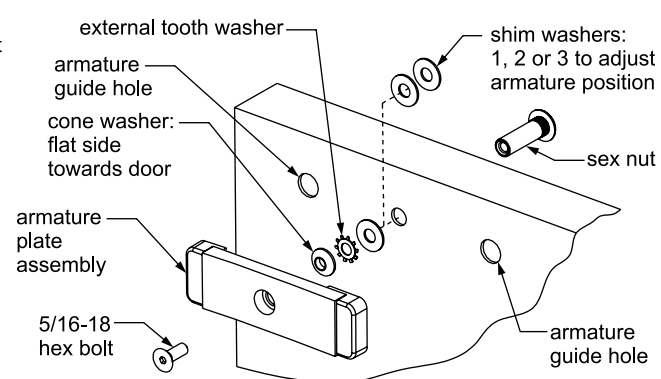

3) Refer to wiring chart and make wiring connections.

WIRING:	
Red (+)	0.300A@12VDC
Black (-)	0.150A@24VDC
White	MBS C
Green	MBS NO
Orange	MBS NC
} 1.0A max.@30VDC	
Contact shown with lock unlocked	
Yellow	DSM C
Blue	DSM NO
Brown	DSM NC
} 0.10A max.@30VDC	
Contact shown with door opened	

4) Install magnet.

NOTE: Magnet and armature must mate when door is in closed (and latched if applicable) position. Adjust by adding/subtracting shim washers.

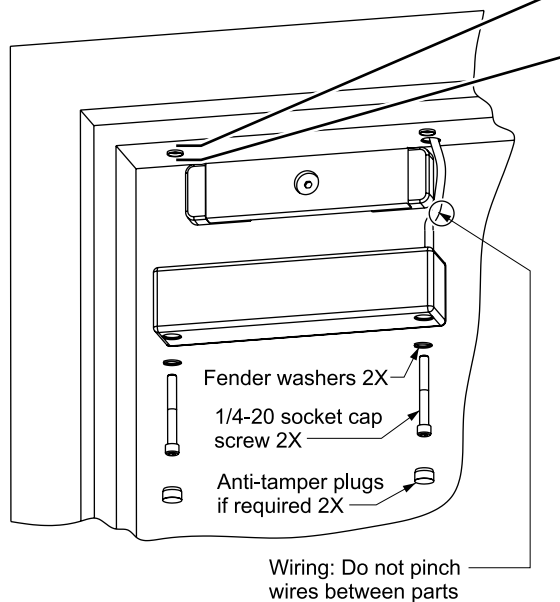

A. Drill a 9/32" hole.

B. Refer to Figure 1.
 • Assemble the supplied parts.
 • Insert into hole.

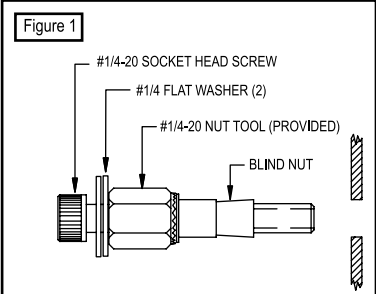

C. While holding tool in place with wrench, tighten to collapse nut with hex wrench. **IMPORTANT: DO NOT OVERTIGHTEN.**

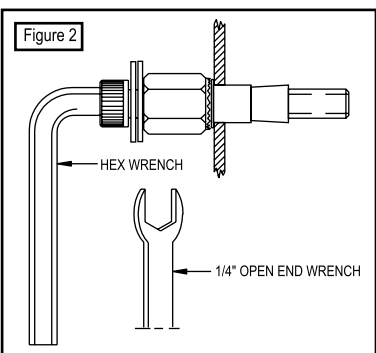

D. Figure 3 shows completed installation of blind nut.

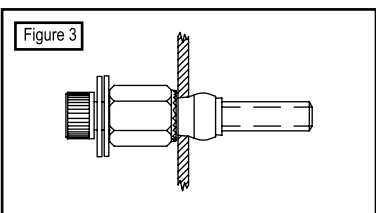

E. Repeat steps A, B and C for additional blind nuts.

700195-A 8/2009

STANDARD SINGLE DOOR

Magnet is typically located near latch side of door for maximum locking power. If required, lock can be mounted vertically. Consult local authority having jurisdiction to ensure compliance with local life safety and electrical codes.

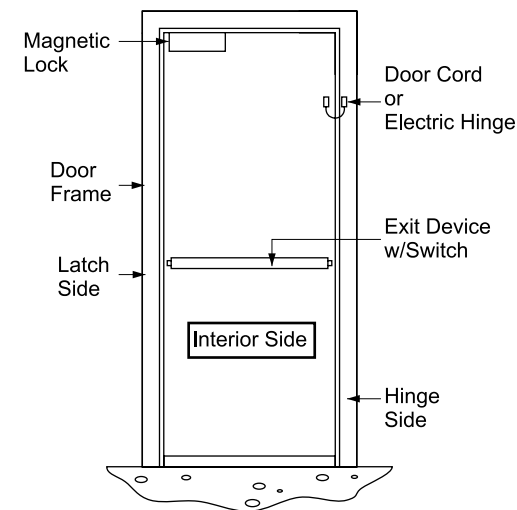

DOUBLE EGRESS DOOR

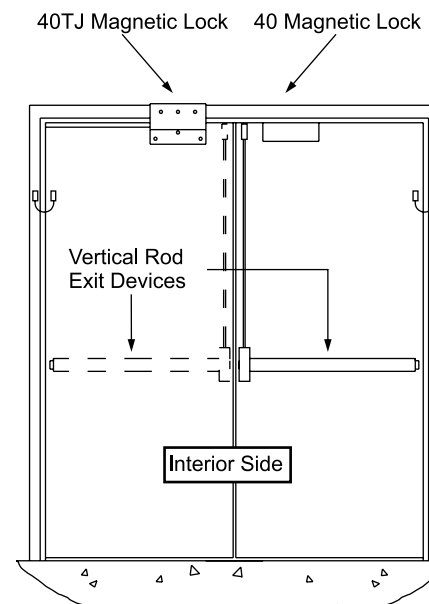

Schlage Lock Company
 575 Birch Street
 Forestville, CT 06010
 technical support: 866-322-1237
 email: SESsupport@irco.com
 web: www.irsupport.net

