



23697287

M490G



Electromagnetic Locks

Installation Instructions

Swinging Application

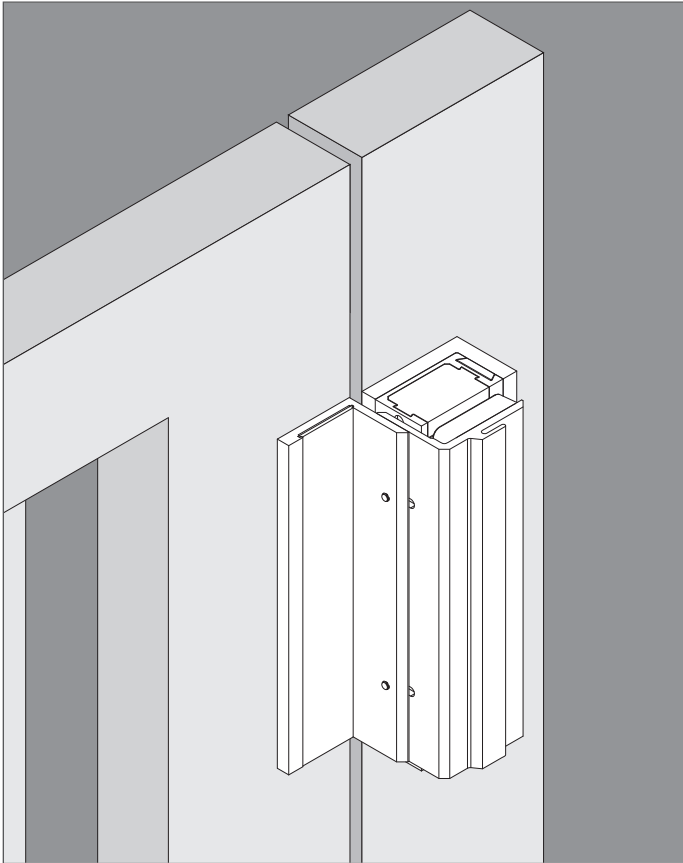

For swinging application, go to page 3.

Sliding Application

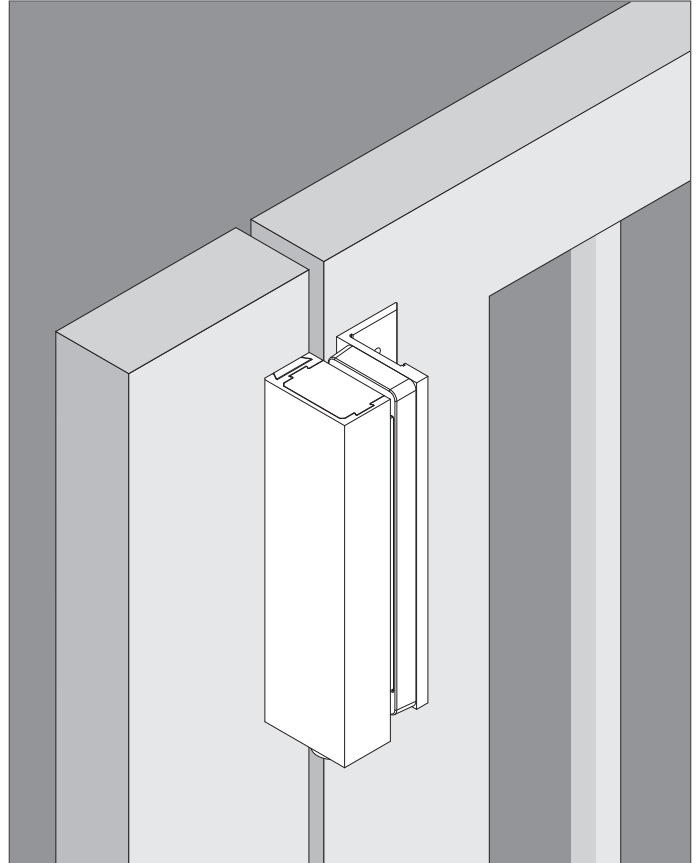

For sliding application, go to page 5.

Features

Magnetic Bond Sensor (MBS)

Detects proper bond between magnet and armature. It can be monitored remotely.

Door Position Switch (DPS)

Indicates whether door is open or closed. This feature is used in conjunction with the MBS.

Electrical Specifications

Model	Amps (12VDC) Per Lock	Amps (24VDC) Per Lock	Holding Force (lbs) Per Lock
M490G	0.650	0.350	1500

Warnings and Cautions

WARNING

Warnings indicate potentially hazardous conditions, which if not avoided or corrected, may cause death or serious injury.

Pre-Installation Considerations

- Use **ONLY** the hardware provided for mounting this product.
- Follow the installation procedure as described in this manual.
- Operational temperature range is -31°F to 151°F (-35°C to 66°C).

Swinging Lock Installation

1 Place template and mark holes.

- a. Place template on gate and post surfaces as marked on template.
- b. Mark holes and prepare them per template.

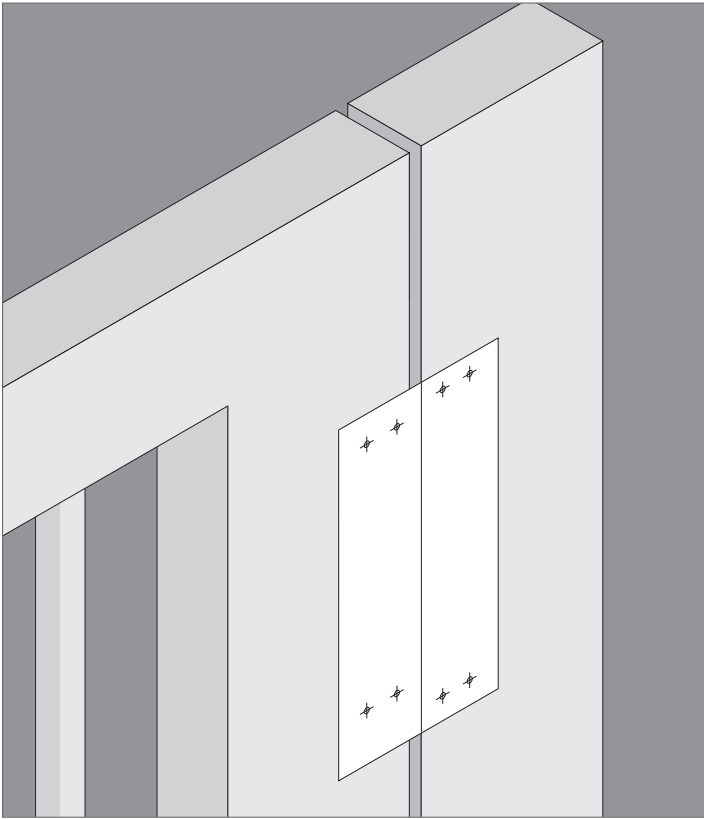

2 Install magnet assembly to non-moving post.

2a Attach L-Bracket to gate.

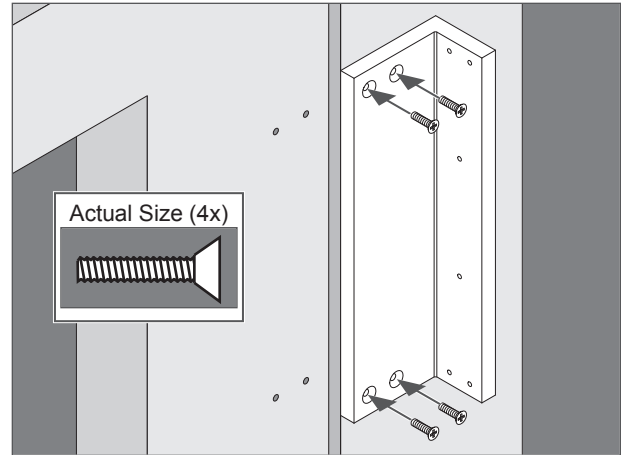

2b Attach mounting bracket to L-Bracket.

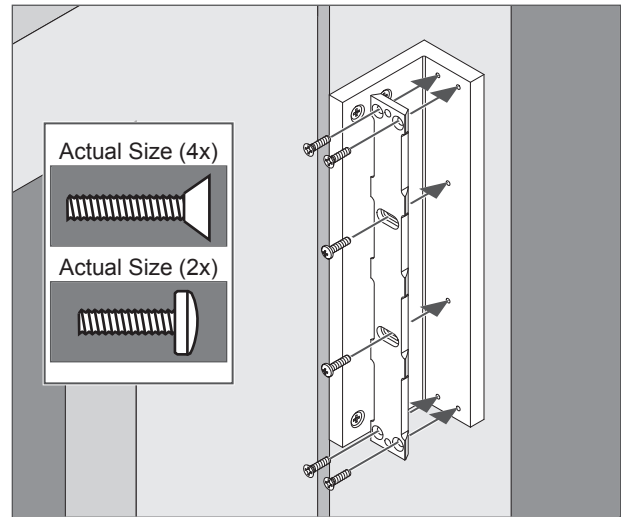

2c Attach magnet to bracket.

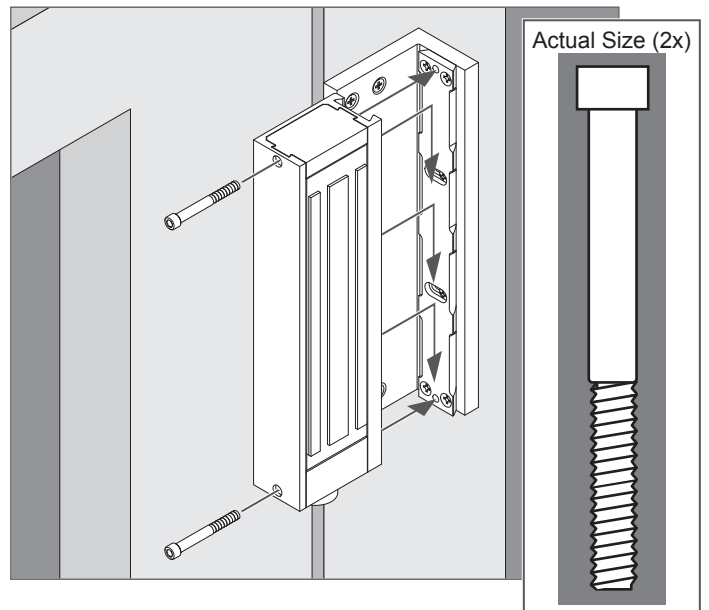

3 Install armature to moving part of gate.

3a Attach TJ bracket to gate.

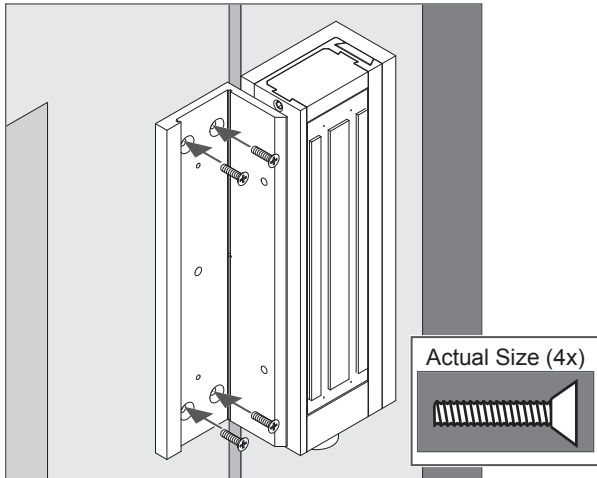

3b Install cover plate.
 a. Slide cover plate onto bracket.
 b. Install set screw.

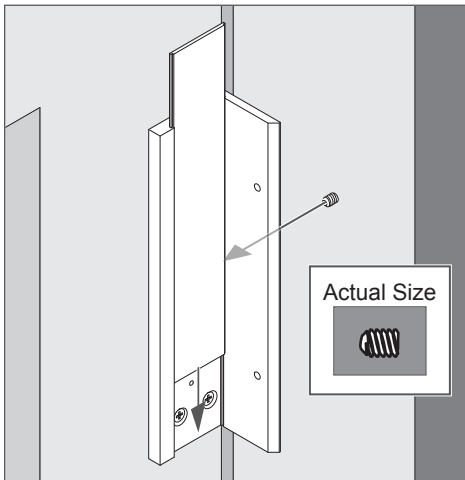

3c Attach armature holder to second TJ bracket.

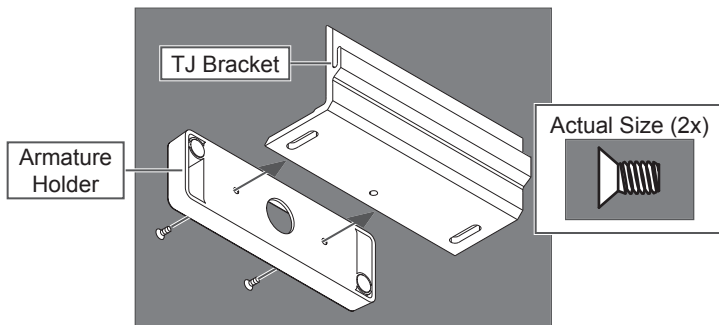

3d Attach armature plate to armature holder.

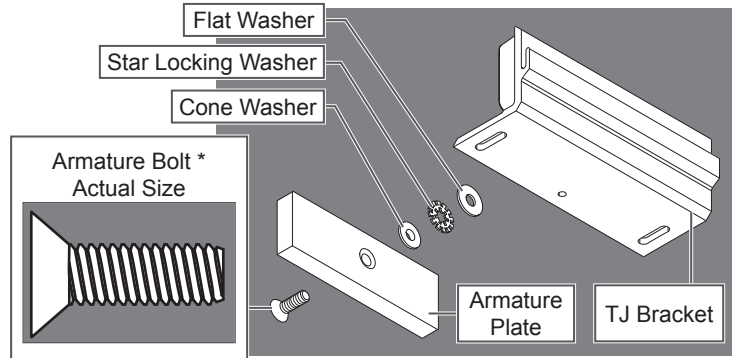

* Armature bolt must be tightened to 120 in-lbs. Replace with bolt in Gate kit. M490 armature must be disassembled to replace armature bolt.

⚠ WARNING
 Backing off the bolt after tightening will loosen the thread-locking patch, which may allow the bolt to loosen over time.

3e Attach two TJ brackets together.

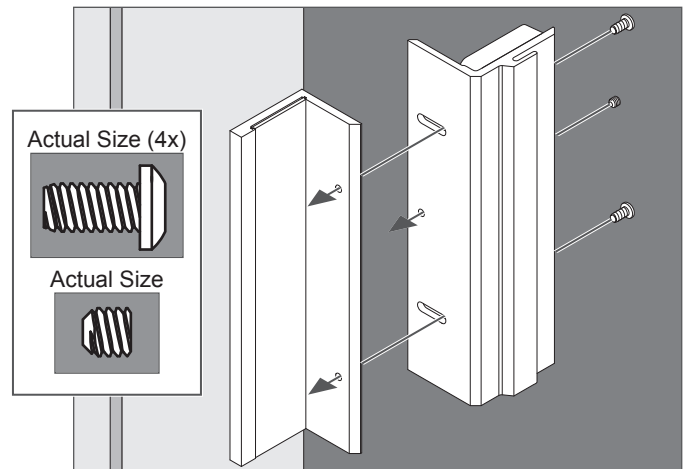

3f Align magnet to armature.

- Close gate.
- Press magnet to fully engage with armature.
- Fully tighten two screws and set screw to lock position.

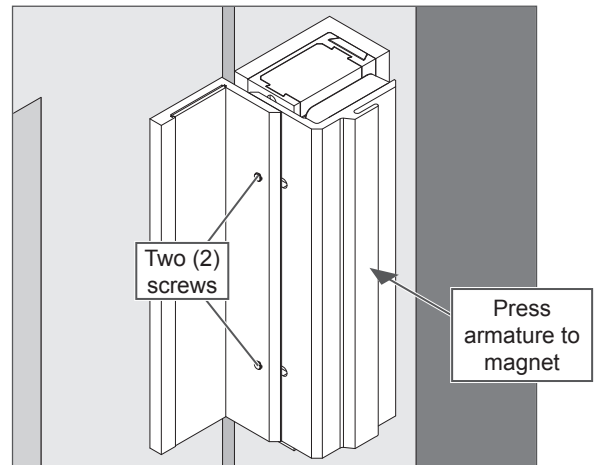

For Wiring Installation, see page 8.

ⓘ **Note:** Some warming of the device under routine operation is normal.

Sliding Lock Installation

1 Place template and mark holes.

1. Place template on gate and post surfaces as marked on template.
2. Mark holes and prepare them per template.

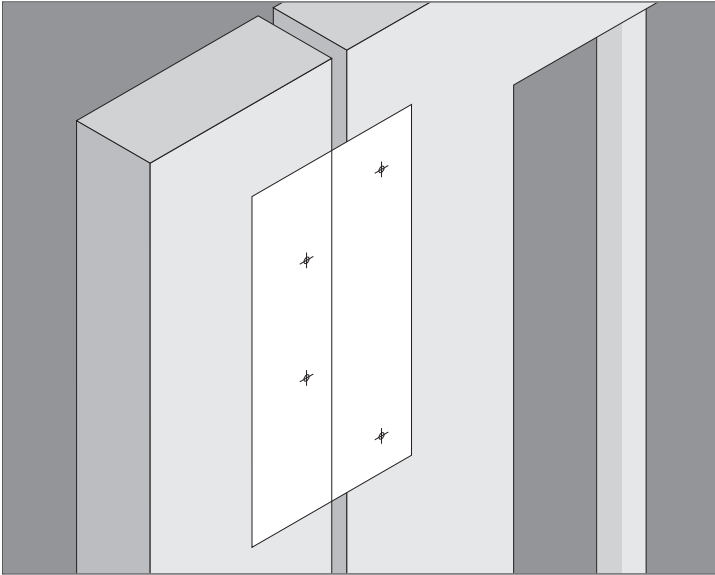

2 Install armature to moving part of gate.

- 2a Attach armature holder to TJ bracket.

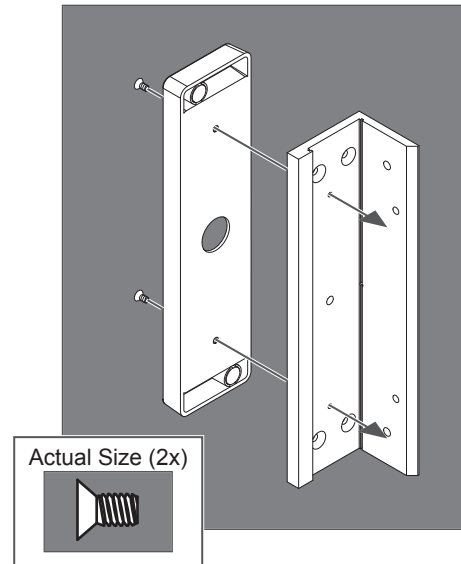

- 2b Attach armature plate to armature holder.

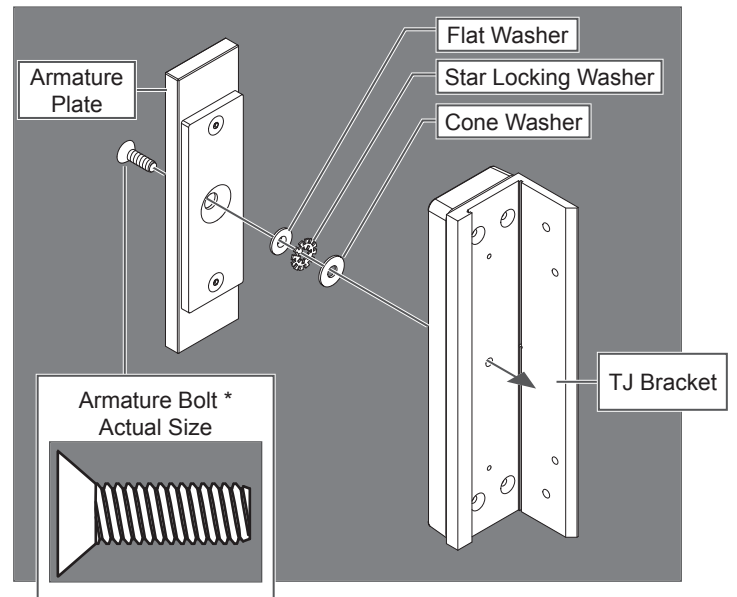

- * Armature bolt must be tightened to 120 in-lbs. Replace with bolt in Gate kit. M490 armature must be disassembled to replace armature bolt.

WARNING

Backing off the bolt after tightening will loosen the thread-locking patch, which may allow the bolt to loosen over time.

2c Install cover plate.

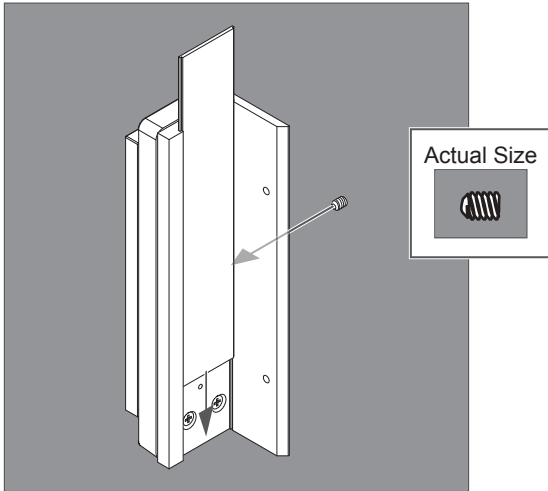

2d Attach Armature Assembly to moving part of gate.

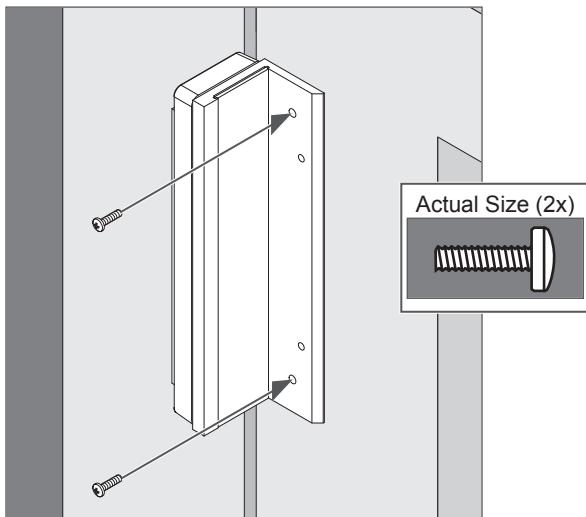

3 Install magnet assembly to non-moving post.

3a Attach mounting bracket to post.

- Attach bracket with two screws through two slotted holes.
- Leave screws loose so that bracket can be adjusted.

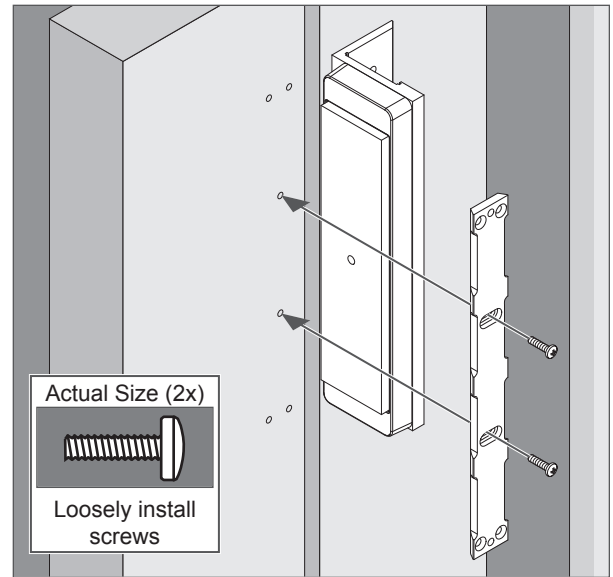

3b Attach magnet to bracket.

- Slide magnet assembly onto mounting bracket.
- Secure magnet with two screws.

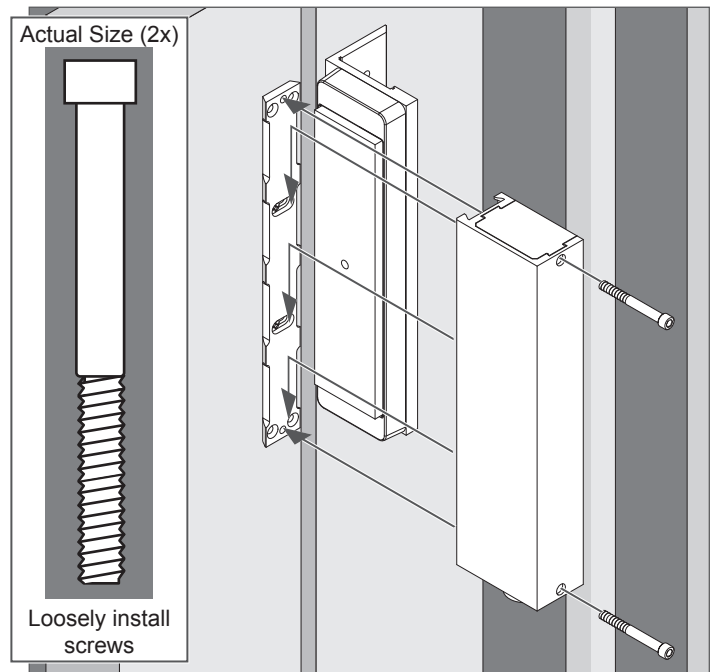

- 3c Align magnet to armature.
 a. Press magnet to fully engage with armature.
 b. Mark bracket location.

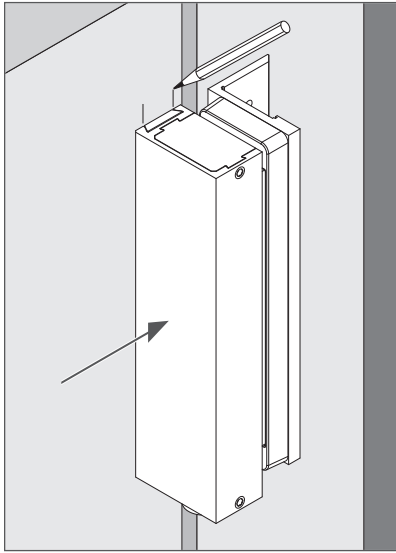

- 3d Remove magnet.

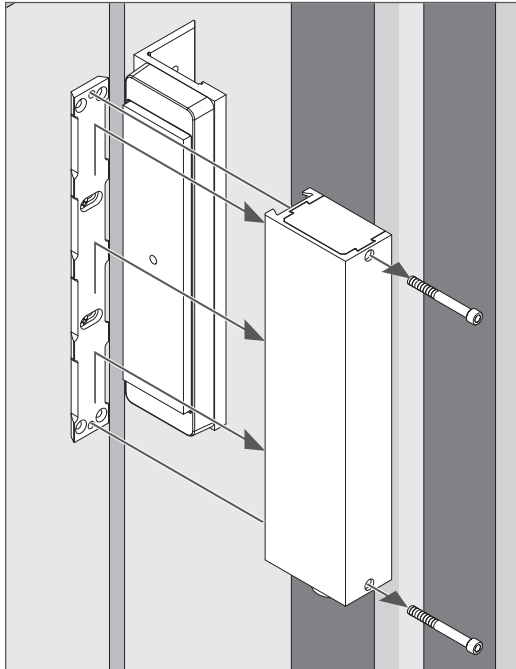

- 3e Fully attach bracket.
 a. Check bracket alignment with marks.
 b. Fully tighten two screws in slotted holes.
 c. Drill and tap four (4) remaining holes for #10-24 screws.
 d. Fully tighten all screws.

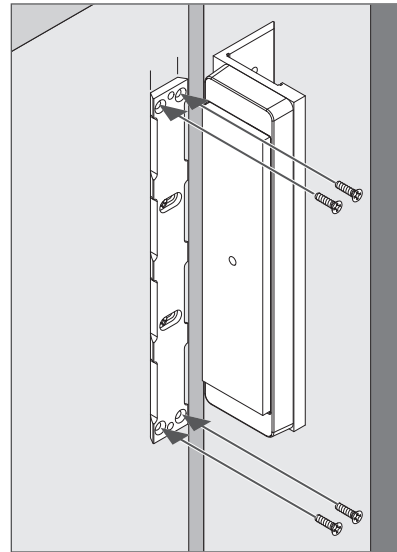

- 3f Reinstall magnet and secure with two screws.

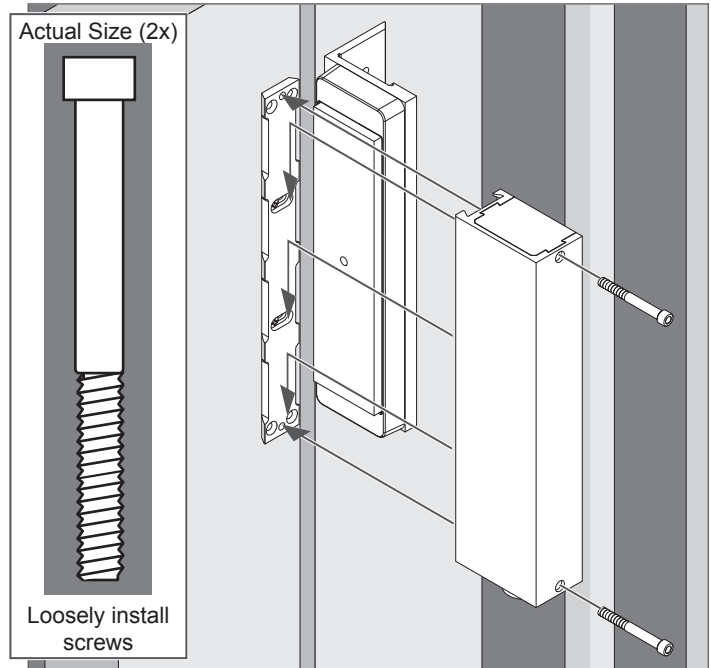

For Wiring Installation, see page 8.

- ⓘ **Note: Some warming of the device under routine operation is normal.**

Wiring Installation

1 Attach wiring per information shown.

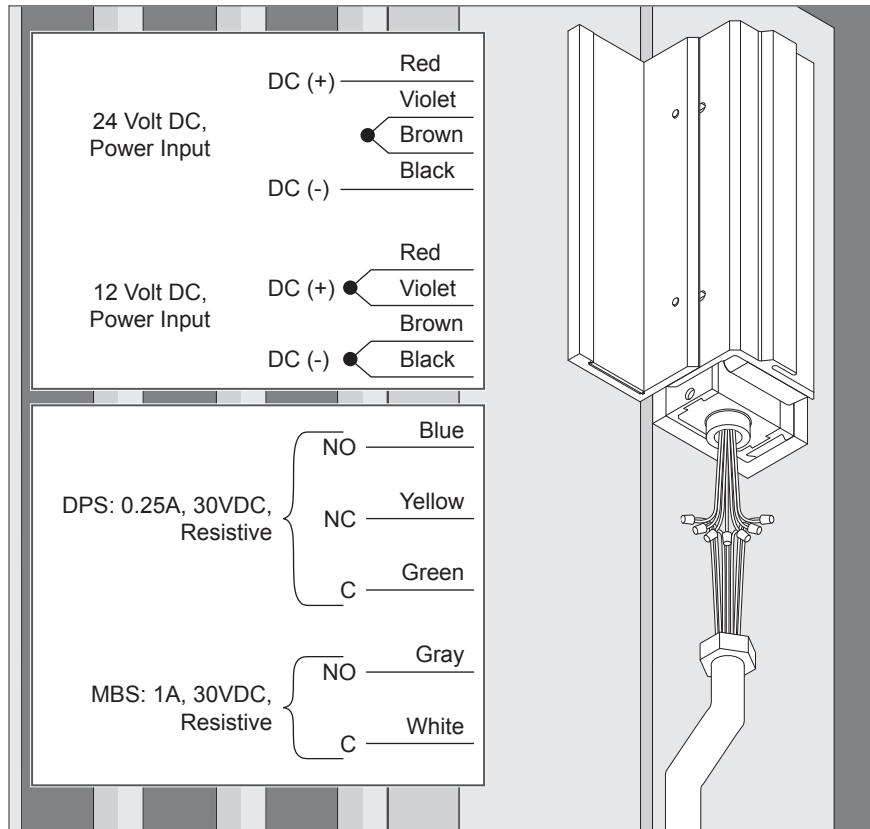

2 Connect conduit to lock.

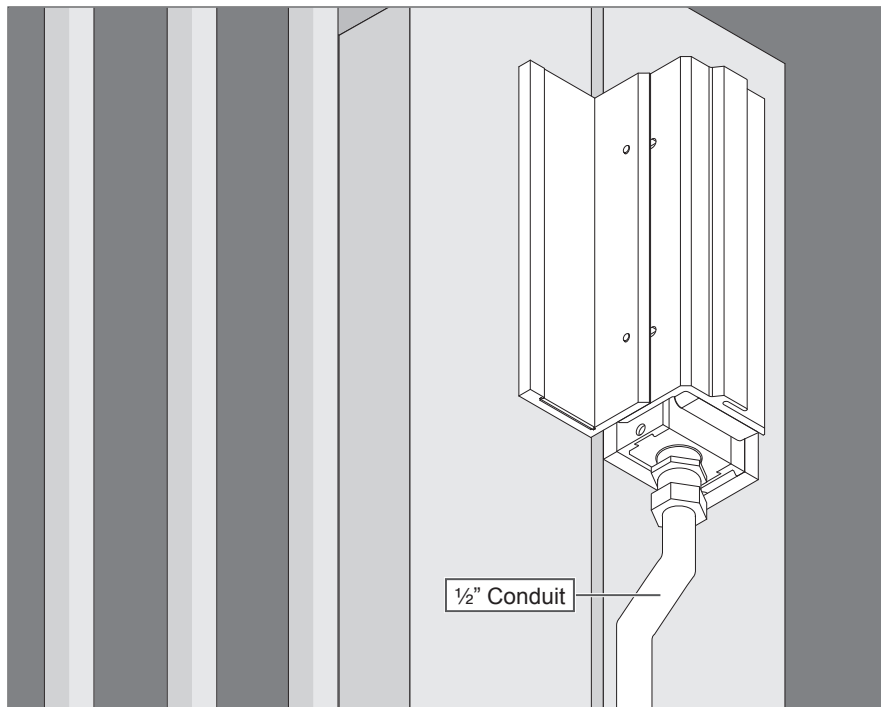

Customer Service

1-877-671-7011

www.allegion.com/us



© Allegion 2015
Printed in U.S.A.
23697287 Rev. 11/15-d