



Detex Corporation, 302 Detex Drive, New Braunfels, Texas 78130-3045
830-629-2900 / 800-729-3839 / Fax 800-653-3839 / Text photos only: 830-481-6433 / INTERNET: www.detex.com

INSTALLATION INSTRUCTIONS FOR ADVANTEX® CONCEALED VERTICAL ROD



Concealed Vertical Rod Exit Device
87 Series - High security
for Medium to Wide Stile
Hollow Metal door applications
Drawing No: 105280

Table of Contents	Page
Device parts breakdown view.....	2
Device parts breakdown list with part numbers.....	3
Hardware List with part numbers & tool required.....	4
Door condition check.....	6
Step 1: Door/opening measurements.....	6
Step 2: Door prep - hollow metal door.....	7
Step 3: Top rod assembly & initial adjustment (80" to 96" door).....	8
Step 3: Top rod assembly & initial adjustment (97" to 120" door).....	9
Step 4: Bottom rod/latch assembly & adjustment.....	10
Step 5: Visual alignment check.....	11
Step 6: Attach top latch mounting brackets.....	12
Step 7: Insert rod/latch/centerlift assembly into door.....	12
Step 8: Secure rod/latch/centerlift assembly to door.....	13
Step 9: Verify centerlift mechanism operation.....	14
Step 10: Hang door/assemble device to door.....	15
Check device clearance.....	15
Install endcap bracket.....	16
Mortise cylinder installation.....	16
Step 11: Top strike installation.....	17
Step 12: Bottom strike installation.....	18
Step 13: Fine latch adjustment.....	18
Step 14: Cover installations.....	19
Optional accessories.....	20

*** NOTE:**

Parts listed will vary according to product configuration.
Mortise cylinder available as an option. Standard Yale type
cam required. See Mortise cylinder installation page.

Your particular part or configuration may not be shown:
Contact Detex technical support at 800-729-3839 (option 2)

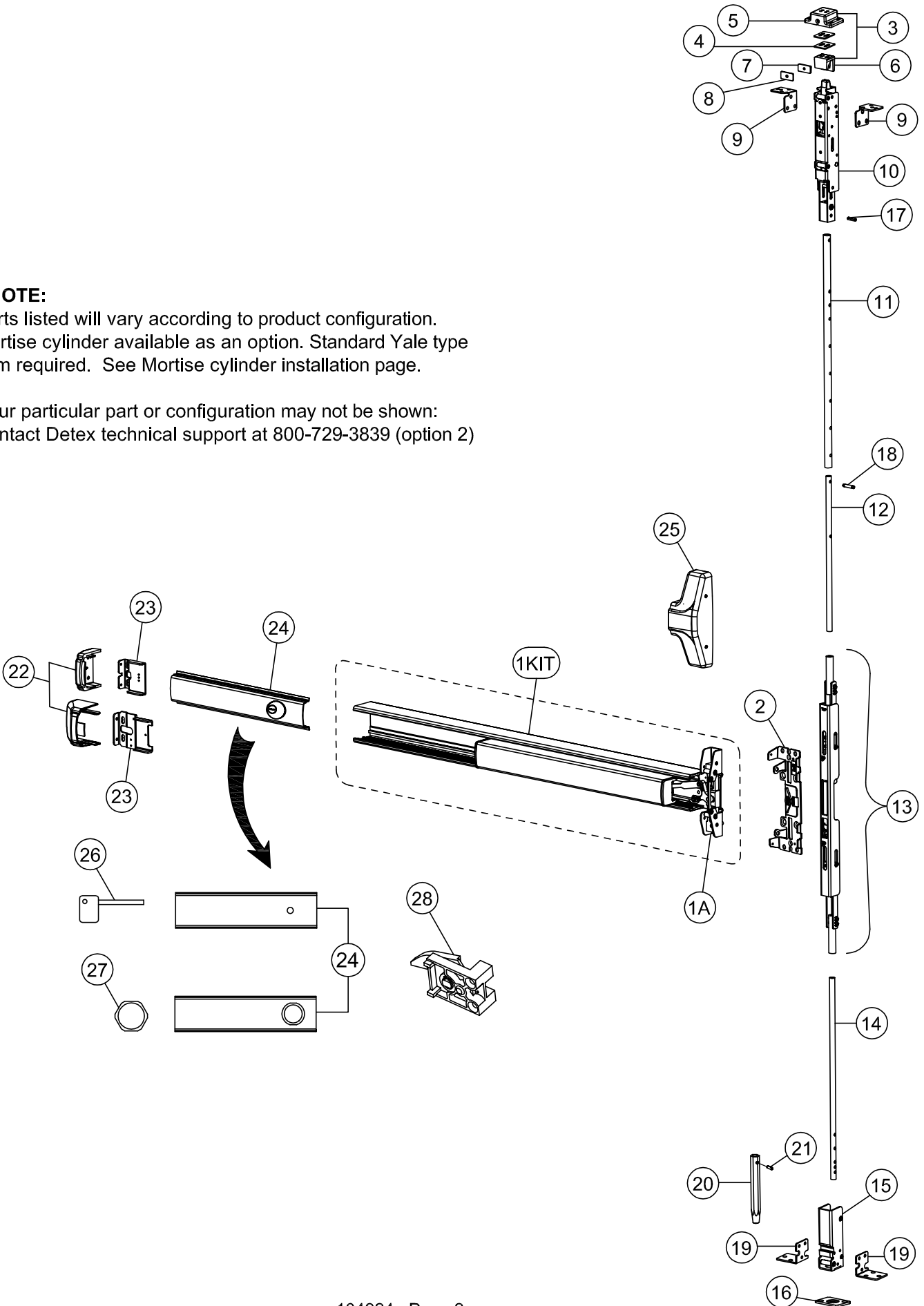





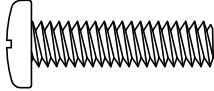
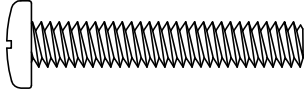

PARTS BREAKDOWN

Item	Part #	Description
1KIT	105500-X	S&R CVR Centercase/Pushpad Assy
1A	104111-13	Centercase, CVR, Wide, RHR
	104111-14	Centercase, CVR, Wide, LHR
2	104171-1	Mounting plate, Wide, CVR, BP11 (Used with 08/09 lever trim)
	104171-2	Mounting plate, Wide, CVR, BP13 (Used with 03 trim)
3	106406-2	Top strike kit, FEMA
4	105246	CVR strike shim
5	105979-1	CVR top strike pocket, FEMA
6	105236-1	CVR top strike insert
7	106145	CVR primary load shim, FEMA
8	106146	CVR supplemental load shim, FEMA
9	106150-1	Top latch mounting bracket, FEMA, RHR
	106150-2	Top latch mounting bracket, FEMA, LHR
10	105984-1	Top latch assembly, FEMA (Panic)
	105984-2	Top latch assembly, FEMA (Fire)
11	104187	Outer top rod, 7' thru 8'
	105097	Outer top rod, 8'-1" thru 10'
12	104172-1	Inner top rod, 7' thru 8'
	104172-2	Inner top rod, 8'-1" thru 10'
13	104175-1	Center lift mechanism assembly
14	105098	CVR bottom rod
15	106330-1	Bottom boltcase assembly, FEMA
16	105257-3	95B Replacement strike kit
17	105296	Spring pin 3/16 x 13/16
18	103423	Spring pin 3/16 x 1/2
19	105982-3	Bottom bolt mounting bracket, FEMA, RHR
	105982-4	Bottom bolt mounting bracket, FEMA, LHR
20	103536-1	Bottom bolt, HURRICANE
21	101607	Spring pin 3/16 x 5/8
22	101642-9	Endcap, EC1 (ramped) Stainless Steel 630
	104304-9	Endcap, EC2 (flush) Stainless Steel 630
	104612-1	Endcap, EC2 (flush) Aluminum 628
23	100147	Endcap bracket for EC1 (ramped) endcap w/o battery holder
	101093	Endcap bracket for EC1 (ramped) endcap w/ battery holder
	104303	Endcap bracket for EC2 (flush) endcap w/o battery holder
	104636	Endcap bracket for EC2 (flush) endcap w/ battery holder
24	100860-54	Fillerplate Subassembly, S&R, Hex Dogging, HD, 630
	100860-49	Fillerplate Subassembly, S&R, Cylinder Dogging, CD, 630
	100860-100	Fillerplate Subassembly, S&R, Hex Dogging, HD, 628
25	102353-9	Centercase Cover, Stainless Steel, Wide, 630
	104640-9	Centercase Cover, Aluminum, Wide, 628
26	100450	Hex Key (for Hex Dogging)
27	100783	Cylinder Nut (for Cylinder Dogging)
28	102216-2	Hex Dogging Assembly
	102216	Cylinder Dogging Assembly

Your particular part or configuration may not be shown: Contact Detex technical support at 800-729-3839 (option 2)

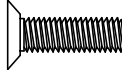
Hardware Table for BASIC device mounting.
Additional hardware is provided per the device configuration in kit form and is addressed on the appropriate pages as required.

Fastener Table		
ADVANTEK 87 Device Mounting Hardware		
Screw style & size	Description	Used on and Drill Bit used
	1/4-20 x 1" PPH Machine screw P/N: 100980	Used to install backplate & endcap bracket to door Drill Bit - #7 or 13/64"
	1/4-20 x 1-1/2" PPH Machine screw P/N: 100954	Used to install backplate & endcap bracket on 2" or greater door thickness with Trim and/or sex nuts Drill Bit - #7 or 13/64"
	10-24 x 1/4" PPH Machine screw P/N: PP-5304-104	Used to secure device centercase to backplate
	10-32 x 5/16" PFH Undercut machine screw P/N: 101632-2	Used to install endcap to endcap bracket (Multiple finishes included)
	6-32 x 3/8" PFH Undercut machine screw P/N: 100162-106	Used to install centercase cover to backplate (Multiple finishes included)
	10-24 x 3/4" PFH Undercut machine screw P/N: 100112-110	Used to fasten centerlift assembly to backplate (Use 100112-110 for 14 gauge or heavier)
	10-24 x 5/8" PFH Undercut machine screw P/N: 100112	Used to fasten centerlift assembly to backplate (Use 100112 for 16 gauge & thinner)
	#14 Lockwasher P/N: PP-5067-25	Lockwashers used with 1/4-20 screws

Sex nuts, if ordered. Sex nuts are used with screws in device hardware kit.

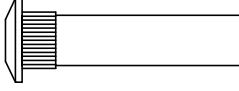
	1/4-20 X 1.60 Sex nut P/Ns: 105274-9 (Stainless Steel) 105274-2 (Brushed Brass) 105274-20 (Oil Rub Bronze)	Used to install backplate and endcap bracket to door If using sex nuts with TRIM: Drill 9/32 hole through interior door face. Drill 1/2 hole through exterior door face. If using sex nuts without TRIM: Drill 3/8 hole through exterior door face.
---	--	--





Tools Required

Power Drill
 Hammer
 Hack Saw (chopsaw preferred)
 Safety Glasses
 Phillips Screw Driver
 Hex Wrench -1/8 & 5/32
 Tape Measure

Tap Wrench
 Masonry Bits - 3/16", 1/4", 5/16", 7/8", & 1"
 Pencil
 Pliers
 Drill bit set
 Center Punch
 Level

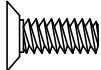
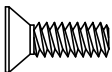

Fastener Table

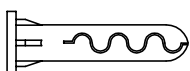
ADVANTEK 87 Strike Mounting Hardware

	#10 x 1" self-cutting PFH P/N: 100109	Used to install bottom strike to floor (used with anchors, two styles of anchor included)
	10-24 x 1/2" PFH Undercut machine screw P/N: 100112-108	Used to install bottom strike to floor (alternate)
	10-32 x 5/8" FHSC Machine screw P/N: 106440-110	Used to secure top strike pocket and top strike insert to header
	8-32 x 1/4" PFH Undercut machine screw P/N: 100156-104	Used to install primary load shim (QTY: 1) to top strike pocket
	8-32 x 5/16" PFH Undercut machine screw P/N: 101950-105	Used to install primary shim (QTY: 1) & supplemental load shim (QTY: 1 or 2) to top strike pocket
	8-32 x 7/16" PFH Undercut machine screw P/N: 101950-107	Used to install primary load shim (QTY:1) & supplemental load shims (QTY: 3 or 4) to top strike pocket
	Anchor (1" long) P/N: 101129-1	1/4 pilot hole Used to install bottom strike to floor
	Alligator Anchor (5/16 x 1-9/16) P/N: 102642-6	1/4 pilot hole Used to install bottom strike to floor

Fastener Table

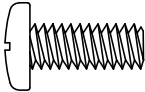
ADVANTEK 87 Latch Mounting Hardware

	1/4-20 x 5/8" PPH, SS Machine screw P/N: 100110	Used to install top latch mounting brackets to door
	10-24 x 1/4" BHS, BLK Machine screw 1/8 Socket HD P/N: 106434-104	Used to install top latch mounting brackets to top latch assembly

!!!CHECK BEFORE STARTING!!!

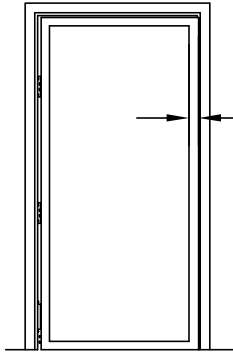

Stile width
Verify that minimum stile width requirement is met.

Doors and frames with walls having a structural thickness (metal skin plus reinforcement) to engage less than (3) full screw threads, are considered unreinforced for hardware.

Unreinforced Doors: Use Sex Nuts and Bolts
Unreinforced Frames: Use Blind Rivet Nuts (see sketch).

Fasteners for unreinforced openings are not supplied by Detex.

Reinforced door or frame engages at least (3) screw threads.

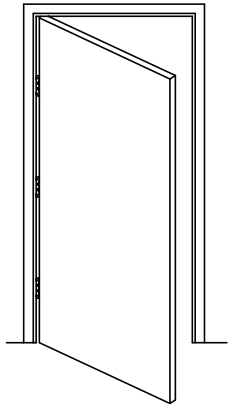
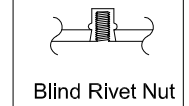
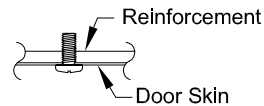

Door Must Swing Freely

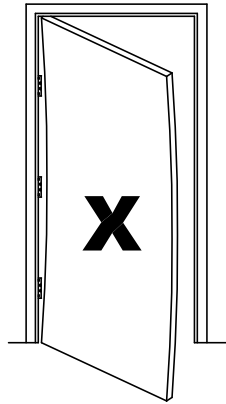

Door Must Not be Warped

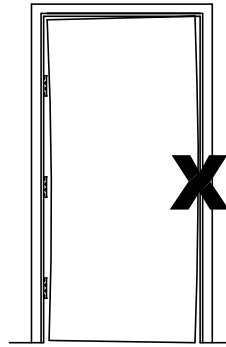

Door Must Not Bind

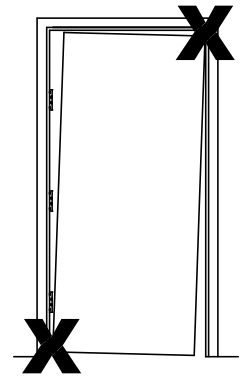

Door Must Not Sag

NOTE: LOCAL CODES MAY REQUIRE THROUGH BOLTING. SEX NUTS ARE **NOT** INCLUDED WITH THIS DEVICE. SEX NUTS CAN BE PURCHASED SEPARATELY.

STEP 1: DOOR / OPENING MEASUREMENTS

Measure per figure below:

*These dimensions will be needed during rod length adjustment. Measure door before removing.

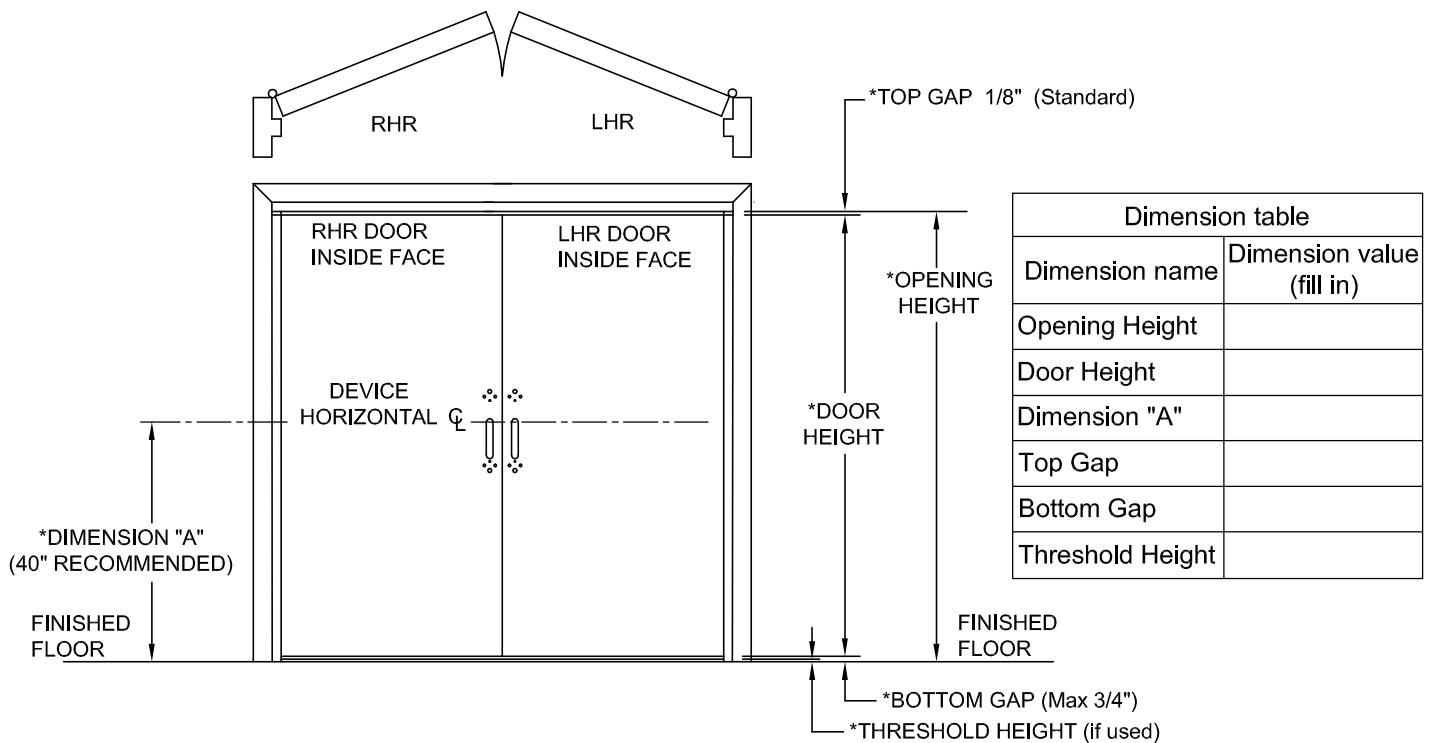

Dimension table	
Dimension name	Dimension value (fill in)
Opening Height	
Door Height	
Dimension "A"	
Top Gap	
Bottom Gap	
Threshold Height	

STEP 2: DOOR PREP - HOLLOW METAL DOOR

INSTALLATION SHOWN IN THIS INSTRUCTION IS FOR RIGHT HAND REVERSE (RHR);
LEFT HAND REVERSE (LHR) WILL BE OPPOSITE

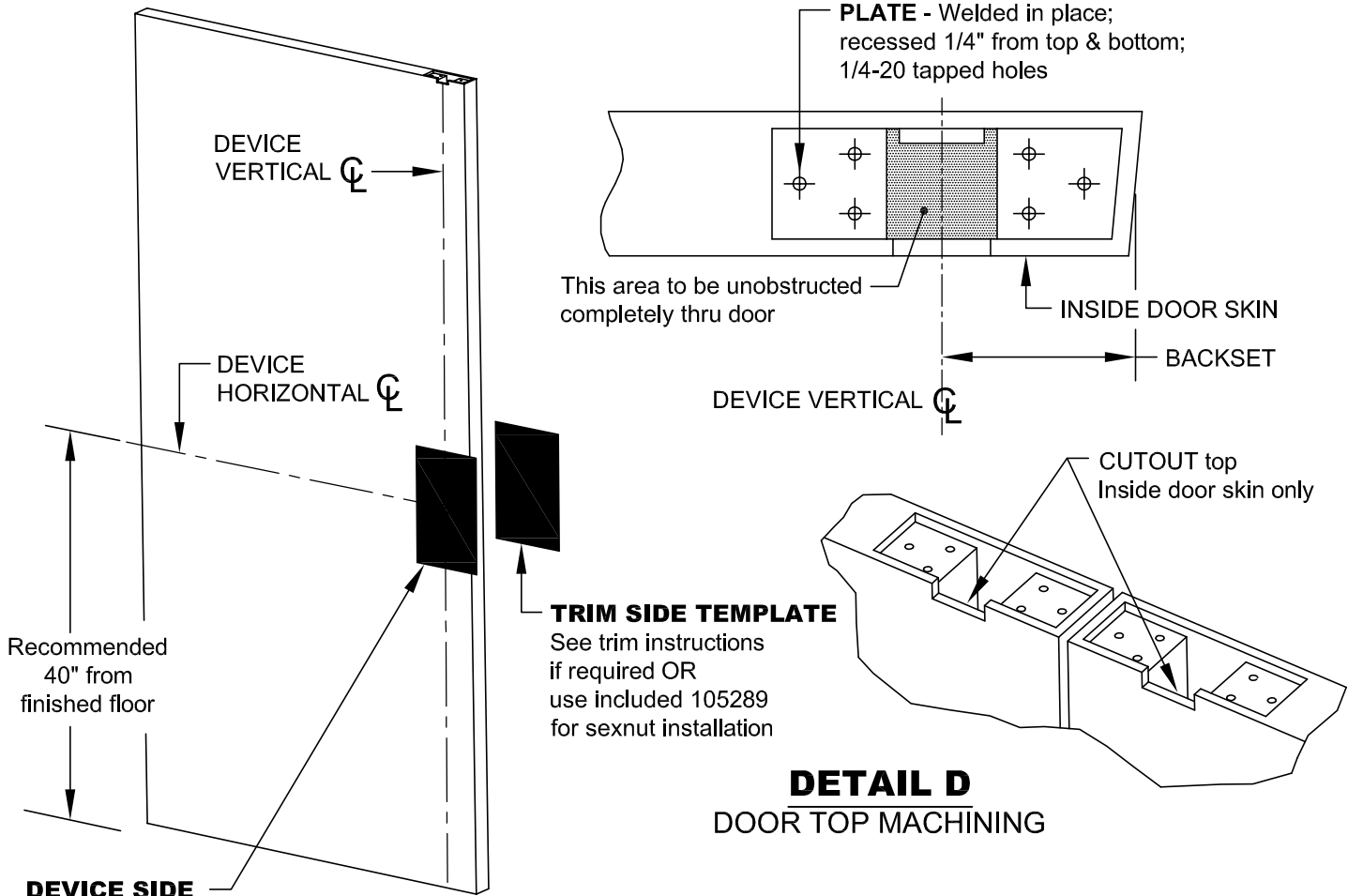

TOP STRIKE FRAME PREP

(if not already prepped)

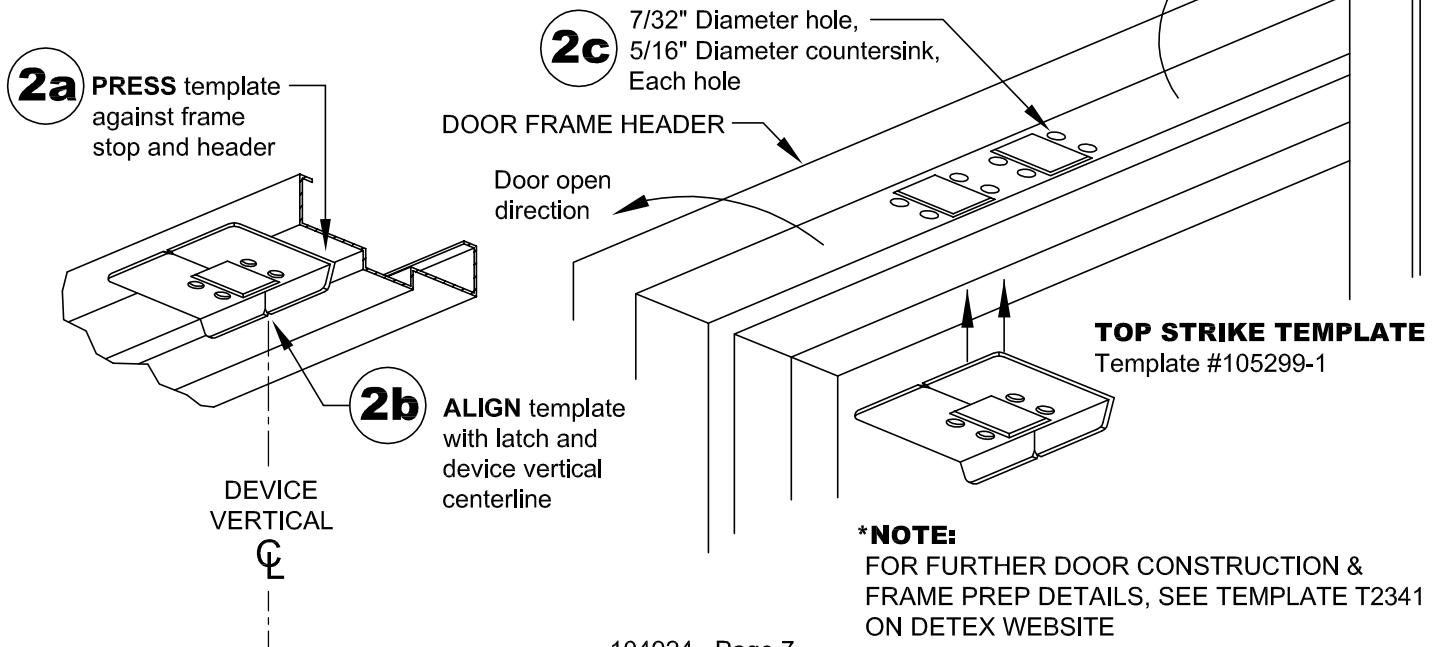

STEP 3: TOP ROD ASSEMBLY & INITIAL ADJUSTMENT

For 6'-8" (80") to 8'-0" (96") Door

3a. Align hole A in rod 104187 with hole in top latch as shown at right & tap the 13/16" long pin into latch hole.

3b. Measure DIM B as shown below.

3c. Use chart to determine pinning location of rods 104187 & 104172-1.
Round DIM B to nearest value in chart. If more than 3/4" different from one of these chart values, drill a .189 (#12 drill bit) diameter hole halfway between the 2 holes nearest to the measured DIM B and use this hole as pinning hole in next step.

3d. Insert 104172-1 rod into 104187 rod & line up appropriate pinning holes (from chart) on both rods and tap in the 1/2" long pin to secure.

3e. Calculate DIM D:
(DIM D = measured DIM B minus 15 7/8")
Thread the assembled rods/latch into the centerlift mechanism assembly as shown at right until DIM D is achieved (within 1/16").

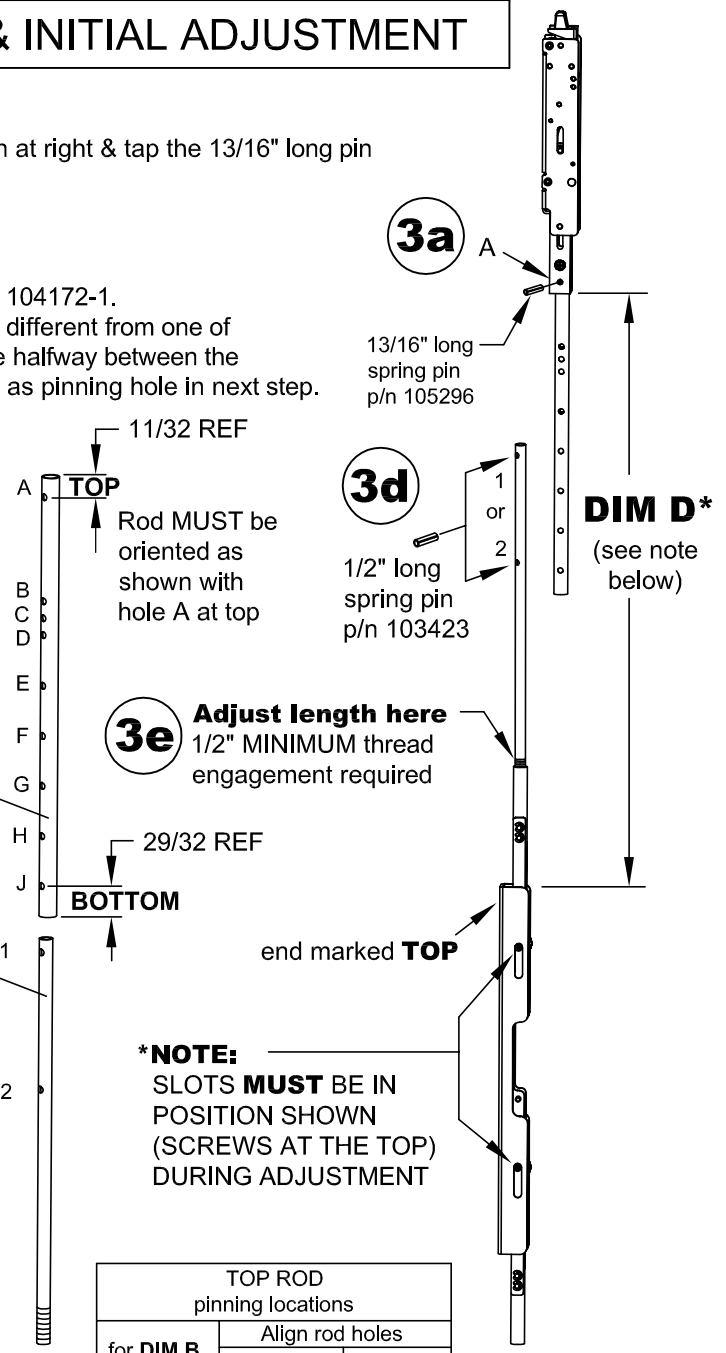
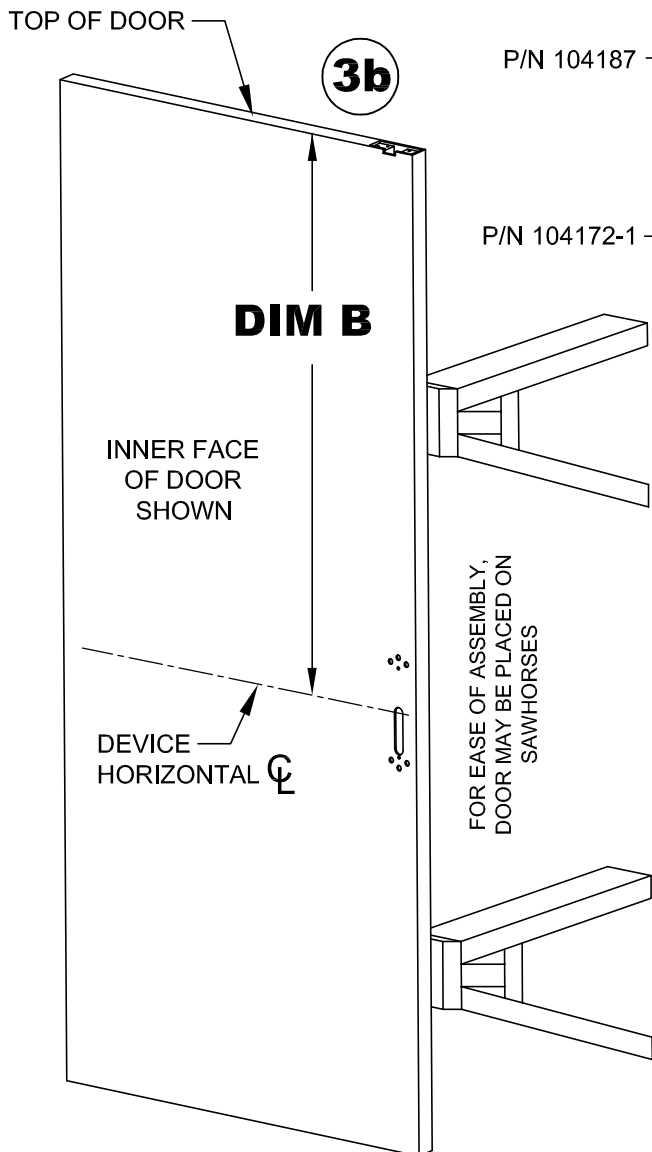

TOP ROD pinning locations		
for DIM B dimension of:	Align rod holes	
	Rod p/n 104172-1 HOLE	Rod p/n 104187 HOLE
39-7/8"	2	B
40-7/8"	2	C
41-7/8"	2	D
43-7/8"	1	B
44-7/8"	1	C
45-7/8"	1	D
47-7/8"	1	E
49-7/8"	1	F
51-7/8"	1	G
53-7/8"	1	H
55-7/8"	1	J

Note: If the combination of holes used is 2B or 2C, cut off approximately 2" from the UNTHREADED end of rod 104172-1

STEP 3: TOP ROD ASSEMBLY & INITIAL ADJUSTMENT

For 8'-1" (97") to 10' (120") Door

3a. Align hole A in rod 105097 with hole in top latch as shown at right & tap the 13/16" long pin into latch hole.

3b. Measure **DIM B** as shown below.

3c. Use chart to determine pinning location of rods 105097 & 104172-2. Round **DIM B** to nearest value in chart. If more than 3/4" different from one of these chart values, drill a .189 (#12 drill bit) diameter hole halfway between the 2 holes nearest to the measured **DIM B** and use this hole as pinning hole in next step.

3d. Insert 104172-2 rod into 105097 rod & line up appropriate pinning holes (from chart) on both rods and tap in the 1/2" long pin to secure.

3e. Calculate **DIM D**:
(DIM D = measured DIM B minus 15 7/8")
 Thread the assembled rods/latch into the centerlift mechanism assembly as shown at right until **DIM D** is achieved (within 1/16").

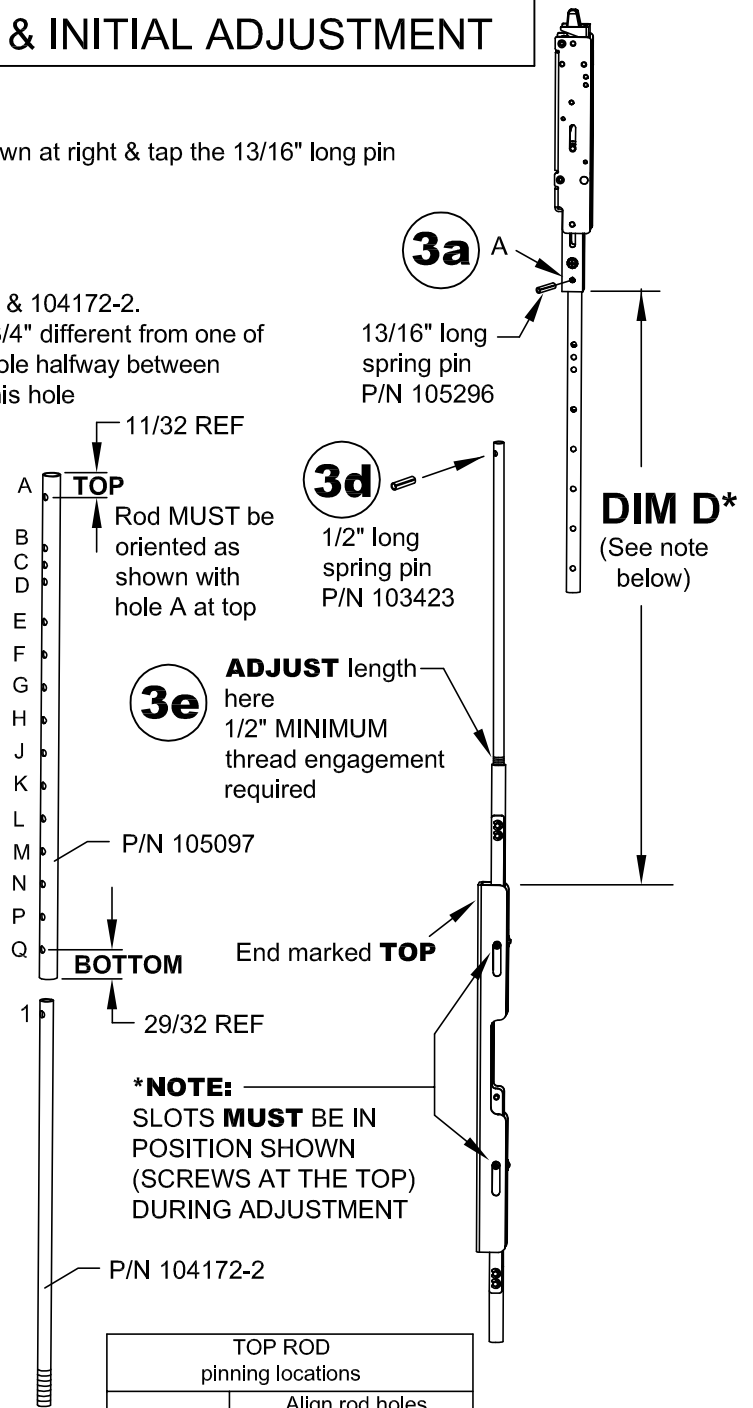
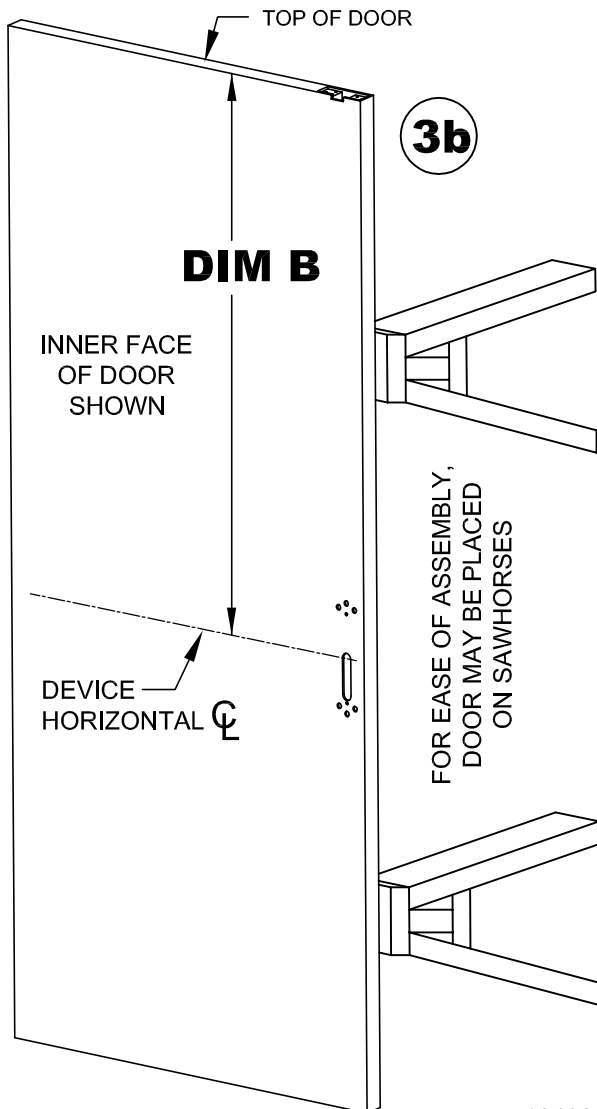

for DIM B dimension of:	TOP ROD pinning locations	
	Align rod holes	
	Rod p/n 104172-2 HOLE	Rod p/n 105097 HOLE
55-7/8"	1	B
56-7/8"	1	C
57-7/8"	1	D
59-7/8"	1	E
61-7/8"	1	F
63-7/8"	1	G
65-7/8"	1	H
67-7/8"	1	J
69-7/8"	1	K
71-7/8"	1	L
73-7/8"	1	M
75-7/8"	1	N
77-7/8"	1	P
79-7/8"	1	Q

STEP 4: BOTTOM ROD / LATCH ASSEMBLY & ADJUSTMENT

4a. Using **DIM A** as measured in step 1, use chart to determine pinning location.

If **DIM A** is **less** than 37-1/4" from finished floor, a new pin hole must be drilled through 105098 rod. Subtract the centerline dimension from 38" and measure up this distance from hole V. Mark and drill .189 diameter hole (#12 drill).

If **DIM A** is **more** than 41-1/2", from floor, call customer service at 1-800-729-3839 for assistance.

4a

Align rod holes with bottom latch (round **DIM A** to nearest value shown)

DIM A (device ϕ at distance from floor)	Bottom Rod p/n: 105098 use HOLE
38"	V
39"	W
40"	X
40-3/8"	Y
40-3/4"	Z



BOTTOM ROD
P/N 105098

Note: If hole V or W is used (or if new hole is drilled closer to threaded end), trim off UNTHREADED end of rod as needed to allow rod to slide into bottom bolt far enough to pin.

4b. Place bottom rod 105098 into bolt, line up holes and secure with spring pin provided.

4c. **DIM C** is the target length.

For no threshold or threshold 1/2" or less:

DIM C = measured **DIM A** minus 8".

For threshold greater than 1/2":

DIM C = measured **DIM A** minus 8" minus threshold height

4d. Thread bottom rod into centerlift mechanism to achieve **DIM C** (within 1/16").

NOTE:

SLOTS **MUST** BE IN POSITION SHOWN (SCREWS AT THE TOP) DURING ADJUSTMENT

4d **ADJUST** length here 1/2" MINIMUM thread engagement required

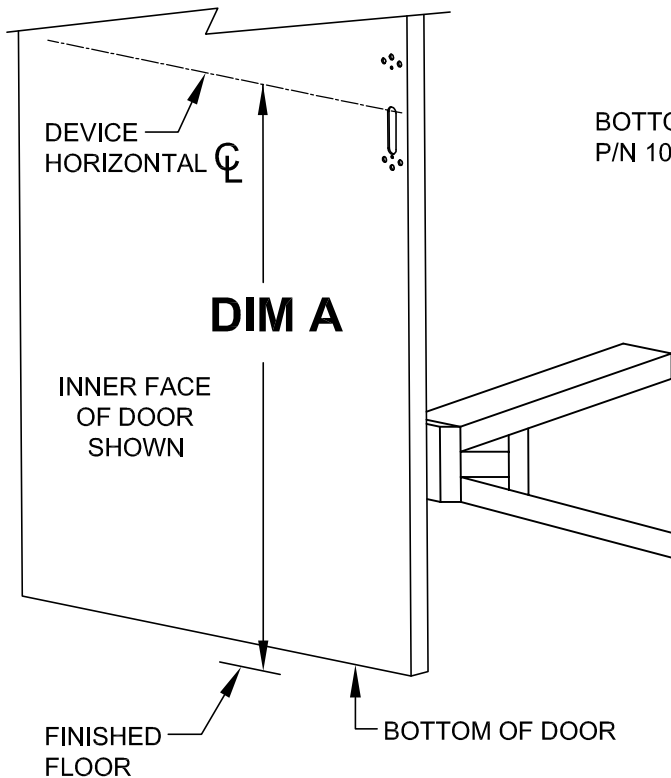

BOTTOM ROD
P/N 105098

4b



SPRING PIN
P/N 101607

DIM C
4c

STEP 5: VISUAL ALIGNMENT CHECK:

5a. Lay internal latch components onto door for trial fit. Take care to protect door finish.

5b. Ensure top latch is in retracted position. Hold top rod in place and push top latch case towards device C until latchbolt is fully retracted.

5c. Mounting holes for centerlift should line up with mounting holes in door, and top and bottom latches should be in position shown. If not, go back to steps 3 & 4 and verify rod length dimensions.

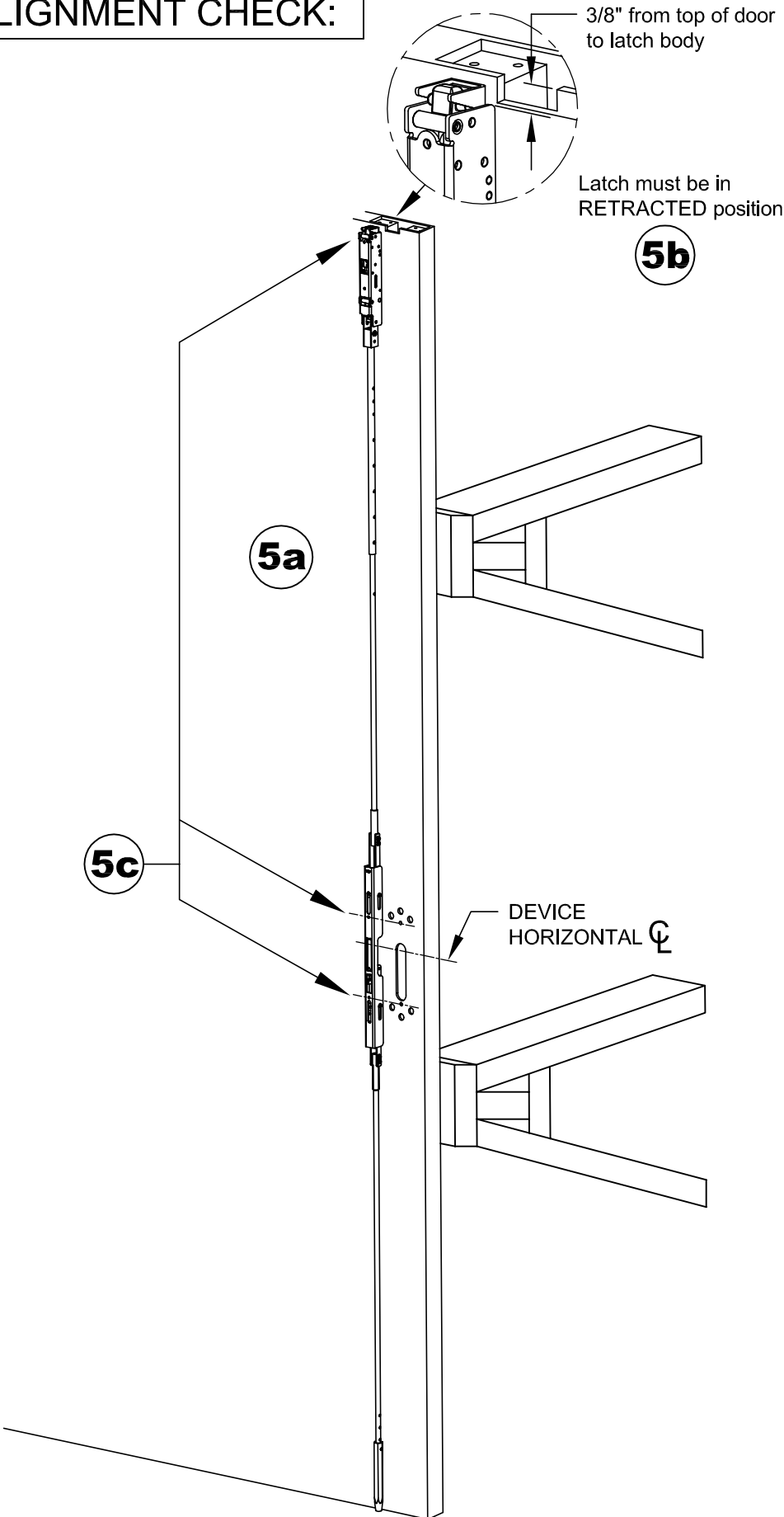

STEP 6: ATTACH TOP LATCH MOUNTING BRACKETS

6 ATTACH top latch mounting brackets as shown below. Three screws required for each bracket.

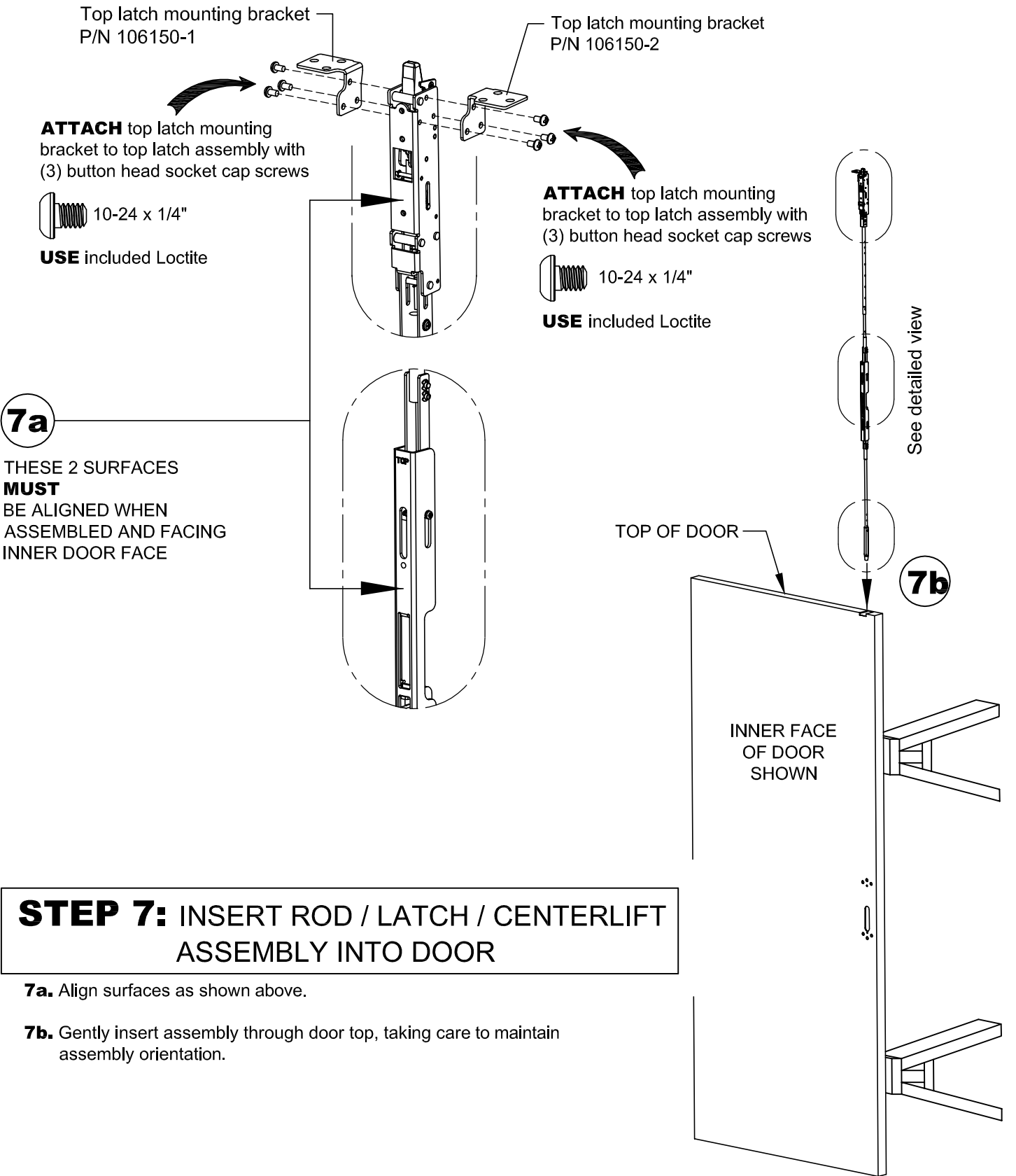

STEP 7: INSERT ROD / LATCH / CENTERLIFT ASSEMBLY INTO DOOR

7a. Align surfaces as shown above.

7b. Gently insert assembly through door top, taking care to maintain assembly orientation.

STEP 8: SECURE ROD / LATCH / CENTERLIFT ASSEMBLY TO DOOR

8a. Attach top latch to door with six screws.

8b. Attach bottom bolt mounting brackets to bottom bolt case with six screws.

8c. Attach bottom bolt case to door with six screws.

8d. Attach back plate to centerlift mechanism with two screws - **DO NOT OVERTIGHTEN**.
 Assembly hint: Assemble one screw loosely without backplate, then add second screw through backplate. Remove first screw, align backplate and then re-install first screw.

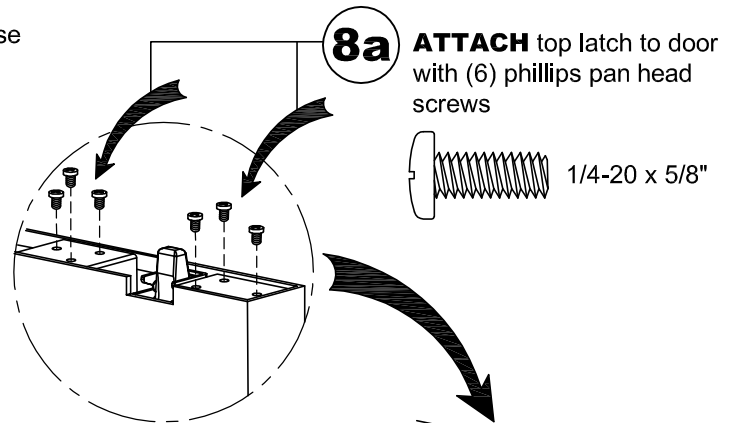

8b **ATTACH** bottom bolt mounting brackets to bottom bolt case assembly with (6) button head socket cap screws

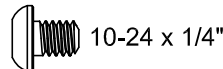

USE included Loctite

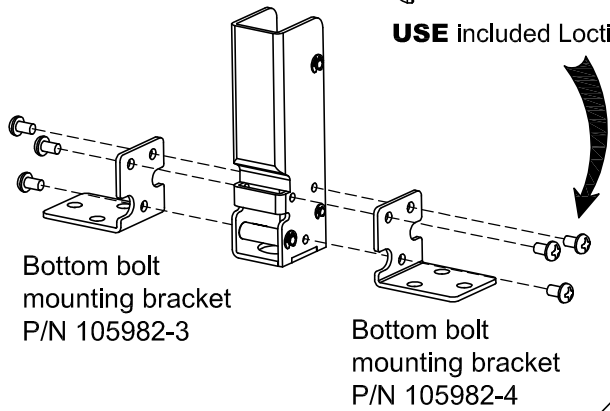

8d **ATTACH** backplate to centerlift mechanism with (2) phillips flat head screws

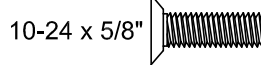

OR

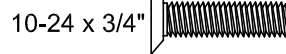

Backplate
BP11 or BP13

8c **ATTACH** bottom bolt case to door with (6) phillips pan head screws

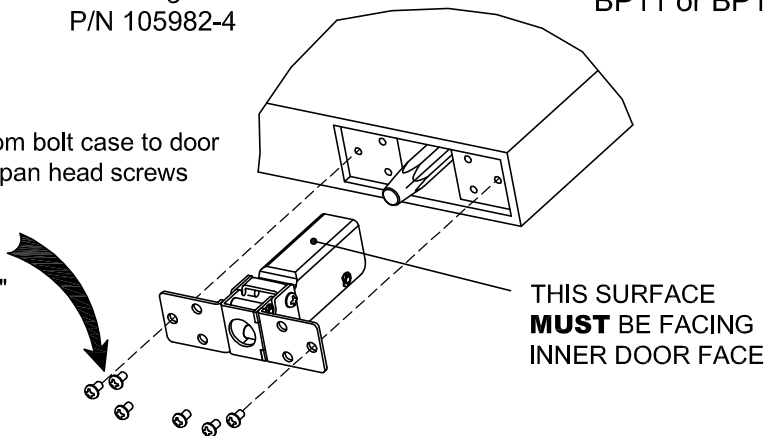
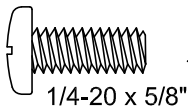

(VIEWED FROM BOTTOM EDGE OF DOOR)

Note: Bottom bracket may slide up on rod during assembly.
 It may be necessary to pull it towards bottom edge of door with a simple wire hook.

STEP 9: VERIFY CENTERLIFT MECHANISM OPERATION

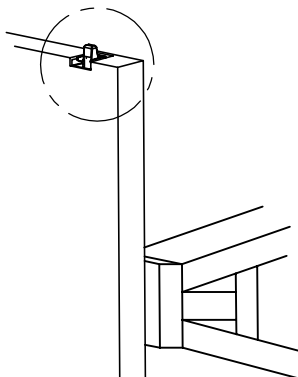
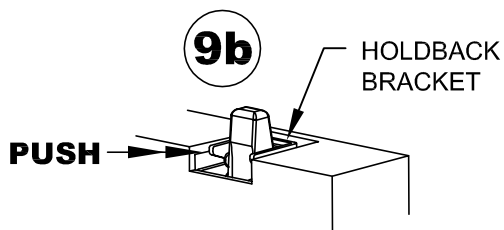

9c
CORRECT POSITIONING
OF ACTIVATION SLOT
AND ADJUSTMENT SCREW
IN LATCH **EXTENDED**
POSITION



9a
ACTIVATION SLOT
LATCH
EXTENDED
POSITION

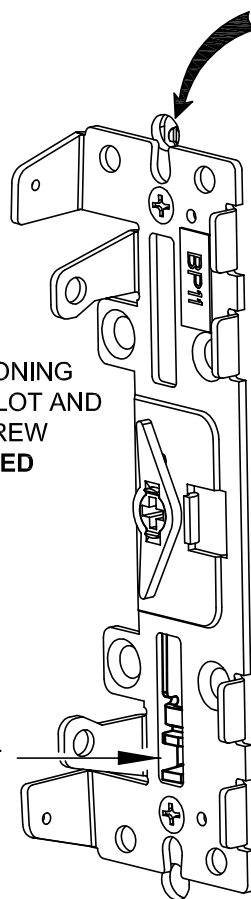
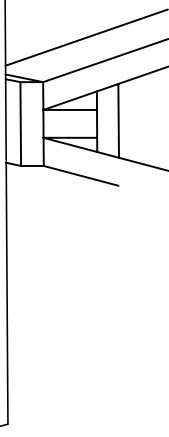

9c
CORRECT POSITIONING
OF ACTIVATION SLOT
AND ADJUSTMENT SCREW
IN LATCH **RETRACTED**
POSITION

9a
ACTIVATION SLOT
LATCH
RETRACTED
POSITION

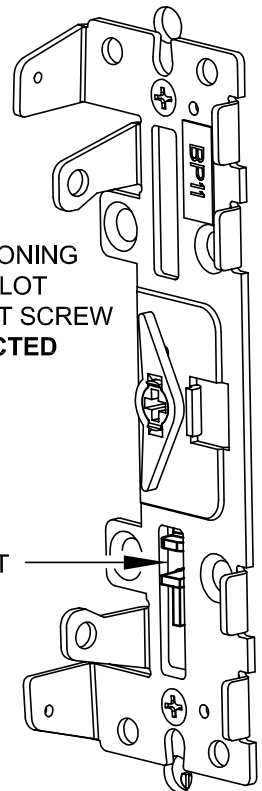

With latch bolt extended, top adjustment screw should be exposed. If not, go back to STEP 3 and make top rod longer.

9a. Check current centerlift position using views shown.

9b. To extend latches, push and hold down on the holdback bracket to disengage the retraction feature, then use a screwdriver inserted into the activation slot to gently lower the slot to the extended position as shown.

9c. To retract latches, gently insert a screwdriver into the activation slot and raise the slot to the retracted position as shown.

TROUBLESHOOTING:

If latchbolt is fully extended while activation slot is not fully in the extended position, **then top rod is too short**. Go back to STEP 3 and correct.

If latchbolt is partially retracted while activation slot is fully in the extended position, **then top rod is too long**. In this case, latchbolt will be fully retracted before activation slot can travel fully to the retracted position. Go back to STEP 3 and correct.

9d. Bottom bolt drag check:

With top latch in retracted position, check to ensure that bottom bolt is not extending from bottom of door a distance greater than the bottom gap at finished floor (minus the threshold height if threshold is used). If it is, **then bottom rod is too long**. Go back to STEP 4 and correct.

9e. Upon completion, retract latches before proceeding to Step 10.

STEP 10: HANG DOOR / ASSEMBLE DEVICE TO DOOR

10a INSTALL DOOR ONTO FRAME PER MANUFACTURER'S SPECIFICATIONS

10b NOTE: LINK SHOULD ALWAYS BE IN TOP POSITION

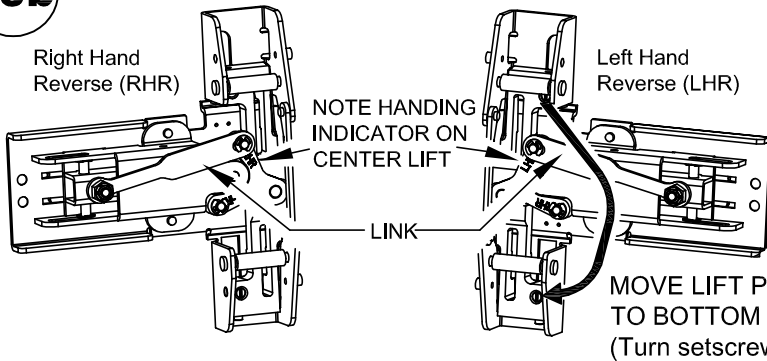

If link is not in uppermost position on the centerlift, carefully remove "E" clips and reposition link on top pin of the centerlift and replace "E" clips. (An additional "E" clip is provided on opposite link pin.) Verify carriage moves up and down smoothly when pushpad is depressed and released.

10c REFER TO TRIM INSTRUCTIONS AT THIS TIME, IF APPLICABLE

MOVE LIFT PIN & SETSCREW TO BOTTOM OF CARRIAGE (Turn setscrew CW to loosen)

10d COMPLETE BACKPLATE MOUNTING

INSTALL backplate with (4) lockwashers & screws OR screws & sex bolts

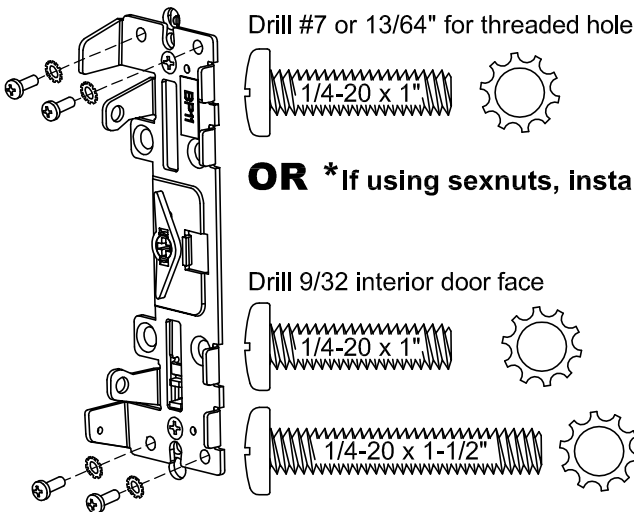

OR *If using sexnuts, install SN3 kit here.

Drill exterior door face
Drill 1/2 (With Trim)
Drill 3/8 (Without Trim)

1/4-20 X 1.60

1/4-20 X 1.60

10e INSTALL DEVICE TO BACKPLATE

Install device to backplate & fasten with 2 screws. Depress pushpad appropriate amount to line up lift pin with tabs

INSTALL with (2) screws

10-24 x 1/4"

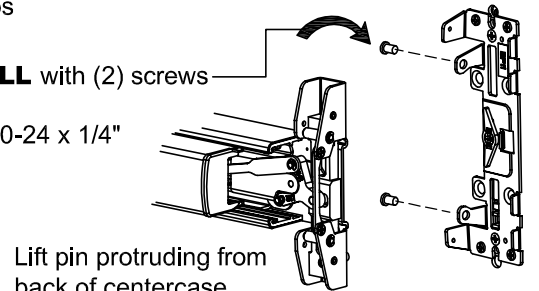

Lift pin protruding from back of centercase. **MUST** be inserted **BETWEEN** these two tabs.

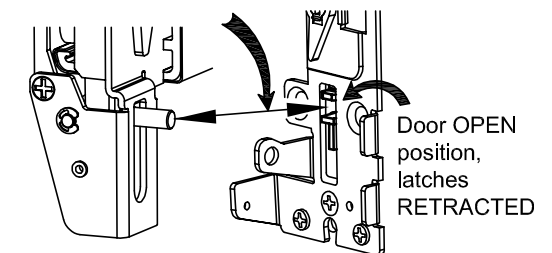

10f CHECKING FOR DEVICE CLEARANCE

(Cut-Off procedure if required)

1 **SLIDE** endcap assembly onto extrusion

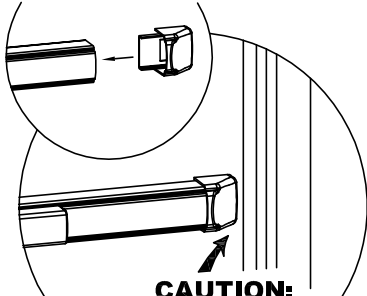

CAUTION:

Check for device and door frame clearance. If no cut-off needed, proceed to the next page.

2 **CUT** fillerplate and extrusion **STRAIGHT & SQUARE** to desired length and deburr. **SECURE** with tape before cutting.

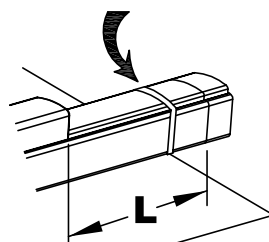

Minimum Fillerplate Length

Type	Length (L)
LD	2-1/2"
HD/CD	3"

For aluminum Advantex finish cutdown applications: After cutting, the baseplate extrusion can be reversed to place the cut end inside the head cover. To do so, loosen the setscrew inside the aluminum baseplate extrusion and slide extrusion out, reverse, & slide back in. Tighten setscrew.

10g INSTALL ENDCAP BRACKET

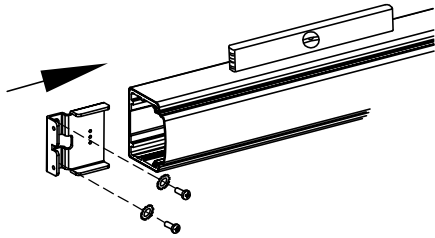

INSTALL bracket with (2) lockwashers & screws **OR** screws & sex bolts

LEVEL device before installing endcap bracket

ENSURE that device does not require cutting (See Step 10f on previous page).

TEST device function after installation of endcap is complete by depressing & releasing pushpad. Action should be smooth with full return of pushpad and latch travel.

Drill #7 or 13/64" for threaded hole

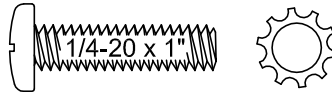

OR *If using sexnuts, install SN3 kit here .

Drill exterior door face
Drill 1/2 (With Trim)
Drill 3/8 (Without Trim)

Drill 9/32 interior door face

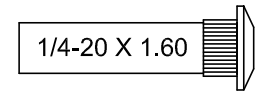
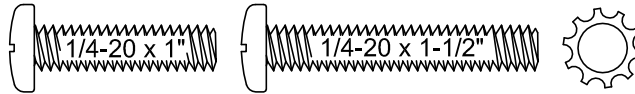

MORTISE CYLINDER INSTALLATION

10h

CD (Cylinder Dogging) Cylinder Installation

Cylinder nut socket
p/n 103779
(sold separately)

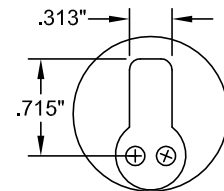
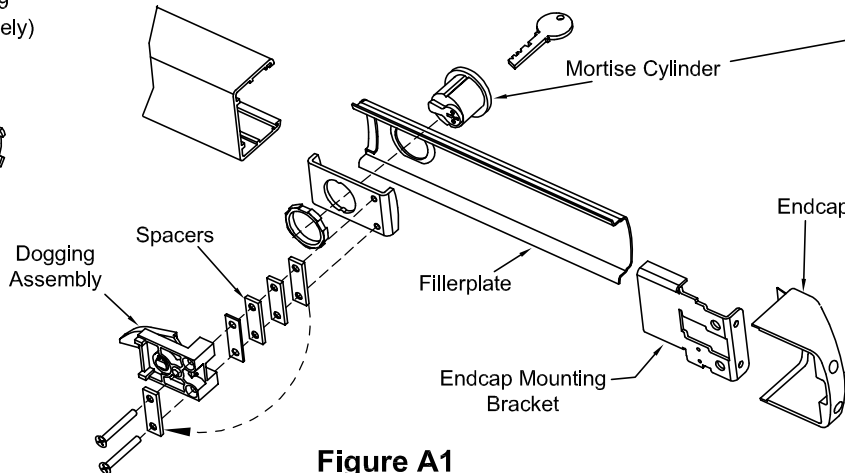
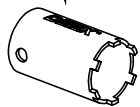

Mortise Cylinder with standard Yale cam required

Figure A1

Follow steps "a" through "g" for CD installations

- Remove endcap and endcap mounting bracket.
- Remove fillerplate.
- Remove and discard shipping insert and nut. Loosen (2) screws from dogging assembly.
- Install mortise cylinder (sold separately) with large hex nut provided.
- Trial fit dogging assembly. If cylinder is too short, remove spacers as necessary and reattach them under the (2) screw heads. Fasten the (2) screws to the rest of the assembly.

NOTE: The key should easily turn in both directions.

- Rotate key counterclockwise
- Assembly complete. Continue with Panic Hardware instruction.

STEP 11: TOP STRIKE INSTALLATION

11a STRIKE ORIENTATION

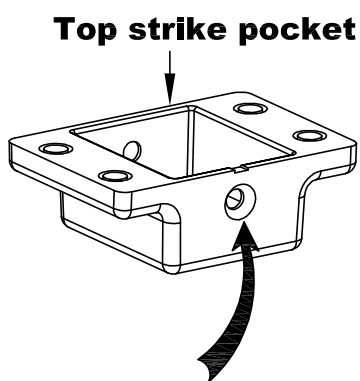

Begin strike installation with notched side of pocket towards inside door face. If additional adjustment is needed, rotate pocket 180°

11b INSTALL LOAD SHIMS

Load Shims are used to maximize device strength. Utilize to fill-in gap between strike insert and strike pocket wall. **Primary shim should always be used.**

Screw used with shims	Supplemental Load Shim QTY
8-32 x 1/4"	0 shims
8-32 x 5/16"	1 or 2 shims
8-32 x 7/16"	3 or 4 shims

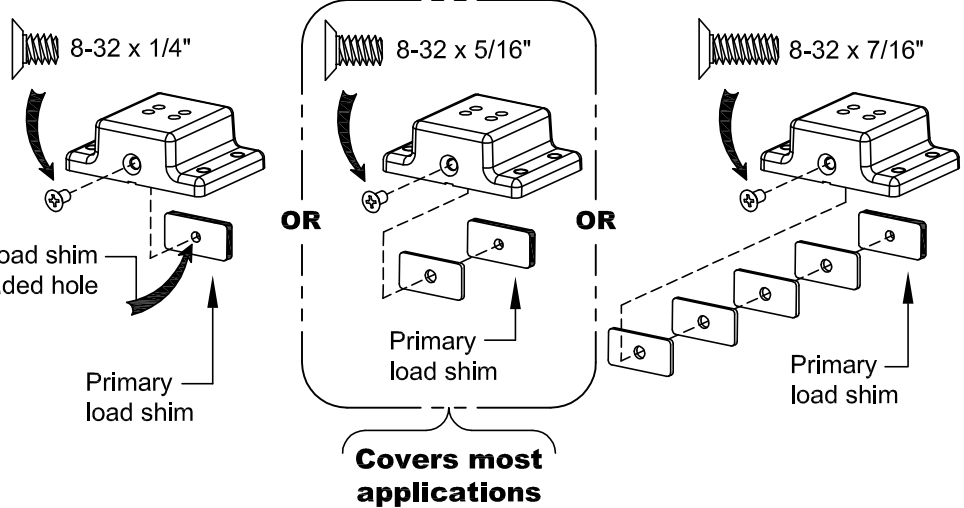

11c INSTALL TOP STRIKE POCKET

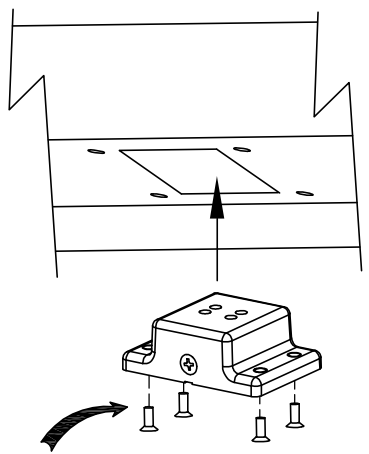

INSTALL top strike pocket with (4) socket cap flat head screws

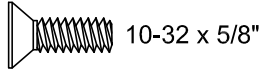

11d INSTALL STRIKE INSERT

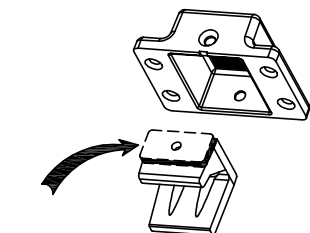

Note: Load shims must be installed **BETWEEN** inside wall of top strike pocket & wall of strike insert as shown.

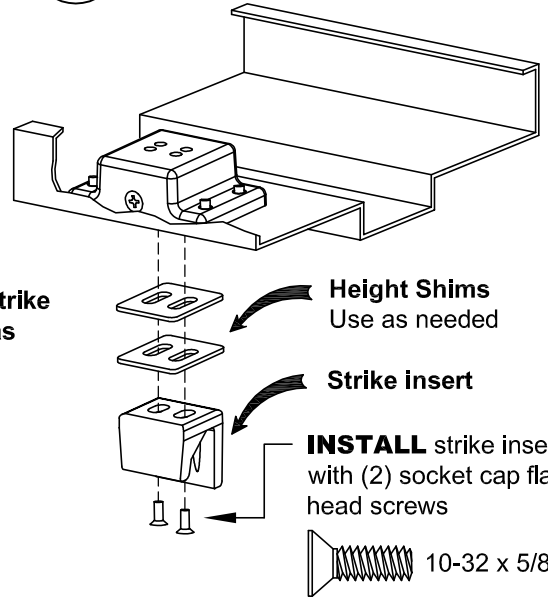

11e FINISHED STRIKE INSTALLATION VIEW

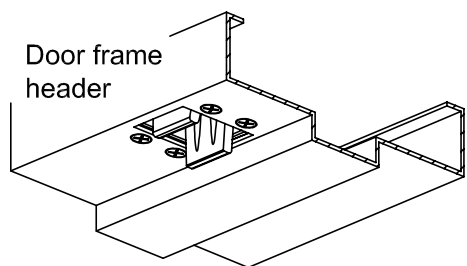

Verify device / strike fit. Adjust the strike insert, load shims, and height shims as needed

Note: Strike pocket must be removed from header in order to adjust load shims.

STEP 12: BOTTOM STRIKE INSTALLATION

BOTTOM STRIKE HOLE LOCATION & DRILLING

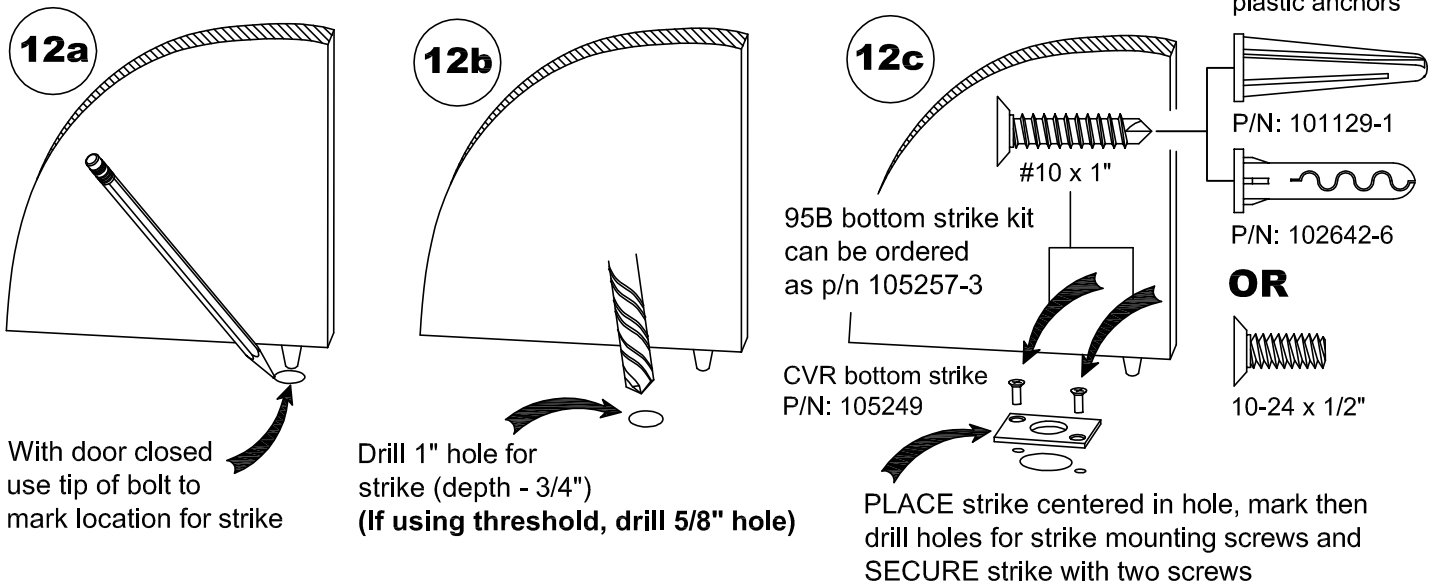

STEP 13: FINE LATCH ADJUSTMENT

13a. Ensure that latches are fully retracted. Gently close door. Latches should extend when door is closed.

13b. Depress pushpad and open door. Top latch should clear top strike & bottom bolt should not drag. Latches should remain in retracted position with pushpad released.

FINE LATCH ADJUSTMENT (if needed) ($\pm 3/8"$ adjustment possible on both top & bottom rods independently. See diagram below.)

13c. Top strike fine adjustment: Adjust strike engagement by either retaining or removing shim. Adjust door tightness by moving insert to desired position. Note that strike pocket can be flipped around to achieve additional adjustment (see step 11).

13d. TOP LATCH ADJUSTMENT: With latches extended, turn CCW until the top latchbolt projection begins to visually decrease, then turn CW until latchbolt projects fully. Rotate CW one additional full turn.

13d Top Adjustment

LATCH **EXTENDED** POSITION
ADJUST WITH FLAT
BLADE SCREWDRIVER
(PUSH IN AND TURN)

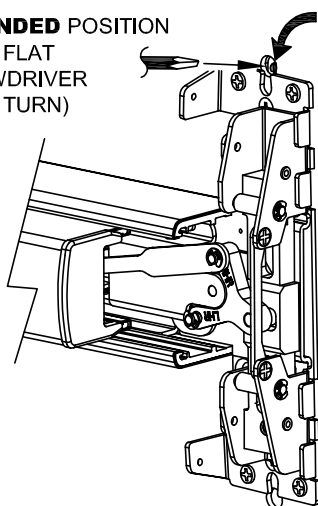

TOP ADJUSTMENT
SCREW EXPOSED

RETRACT BOLT (CCW)



EXTEND BOLT (CW)

CAUTION:
If turned too far CW,
you will lose sight
of adjustment screw

13e Bottom Adjustment

LATCH **RETRACTED** POSITION
ADJUST WITH FLAT
BLADE SCREWDRIVER
(PUSH IN AND TURN)

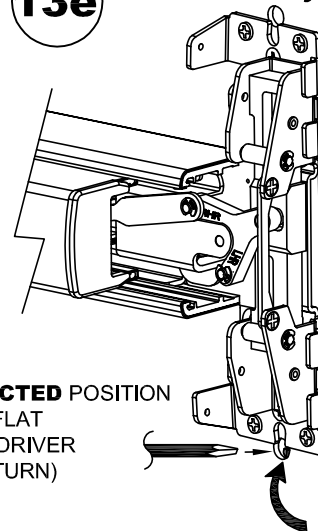

EXTEND BOLT (CCW)



RETRACT BOLT (CW)

BOTTOM ADJUSTMENT
SCREW EXPOSED.
LOWER TO DESIRED
EXTENSION

13e. BOTTOM LATCH ADJUSTMENT: With pushpad depressed (retracted position), extend or retract bottom bolt to desired engagement and clearance.

13f. Check device operation (See Device Operation Troubleshooting table).

Reference STEP 13a & 13b.

DEVICE OPERATION TROUBLESHOOTING

SYMPTOM	POSSIBLE CAUSE	SOLUTION
Device not latching when door closes	Bottom bolt is not properly aligned with bottom strike hole.	Modify bottom strike hole for fit.
	Top strike insert is not installed or not correctly aligned with the holdback.	Install and/or position strike insert per instructions.
	Through fasteners for trim (if applicable) are interfering with internal centerlift assembly.	Loosen and re-position through screws to clear.
	Rods improperly adjusted	Adjust rods per instructions. Remove device and re-install per instructions.
Latches release, but pushpad will not fully depress	Device centercase lift finger not inserted properly into centerlift assembly.	Remove device from backplate and re-install with lift finger correctly inserted.
	Top adjustment screw is adjusted too far in the retracted direction (CCW).	Rotate top adjustment screw in the extended direction (CW) per FINE LATCH ADJUSTMENT procedure.
Latches are not releasing when pushpad is fully depressed	Device centercase lift finger not inserted properly into centerlift assembly.	Remove device from backplate and re-install with lift finger correctly inserted.
	Top adjustment screw is adjusted too far in the extended direction (CW).	Rotate top adjustment screw in the retracted direction (CCW) per FINE LATCH ADJUSTMENT procedure.
	Bottom adjustment screw is adjusted too far in the extended direction (CCW).	Rotate bottom adjustment screw in the retracted direction (CW) per FINE LATCH ADJUSTMENT procedure.

STEP 14: COVER INSTALLATIONS

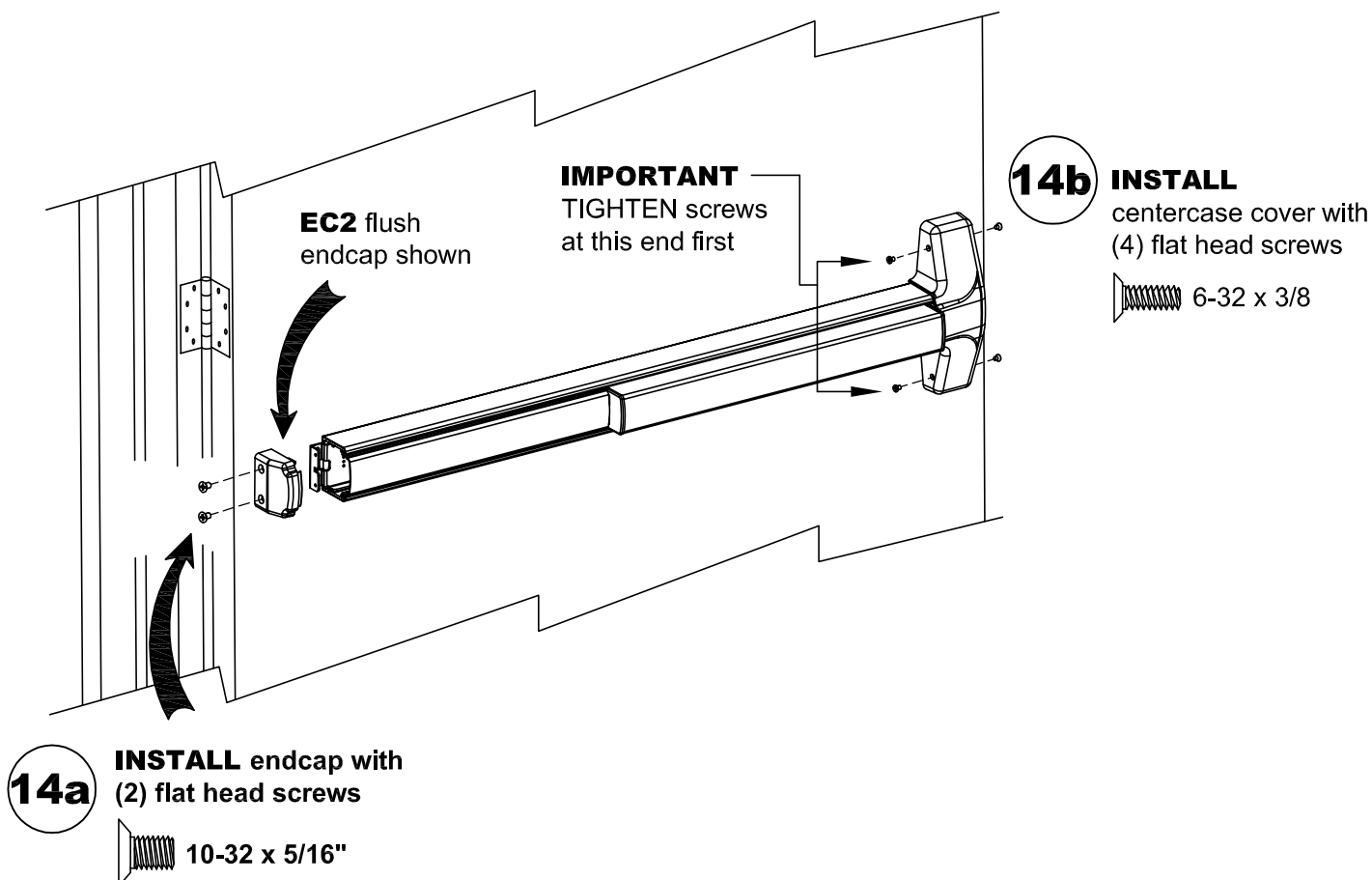

Optional Accessories

Glass Bead Kit

Catalog No:

GB1 for EC1 endcap (p/n 101643)

GB19 for EC2 endcap (p/n 101643-1)

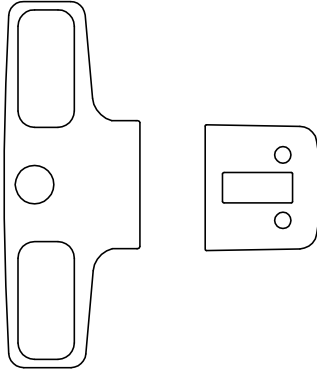

#1/4-20 X 1-1/2" Screws
Included

Sex Nut Kits

The #1/4-20 kits are available in 3 finishes:

Brushed Brass BHMA 606

Oil Rubbed Bronze BHMA 613

Stainless Steel BHMA 630

Catalog No: **SN3** (p/n: 105274-X) (uses screws in hardware kit)

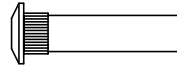

Tamper Kit

(Security Kit)

Catalog No:

SSK1 (p/n 101233 for top & bottom rod applications)

SSK1 (p/n 101233 for top rod only applications)

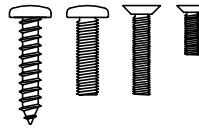

Security Screws

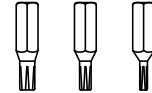

Security Pin TORX® Bits provided

Cylinder nut socket

p/n: 103779

