



Detex Corporation, 302 Detex Drive, New Braunfels, Texas 78130-3045  
830-629-2900 / 800-729-3839 / Fax 800-653-3839 / Text photos only: 830-481-6433 / INTERNET: www.detex.com

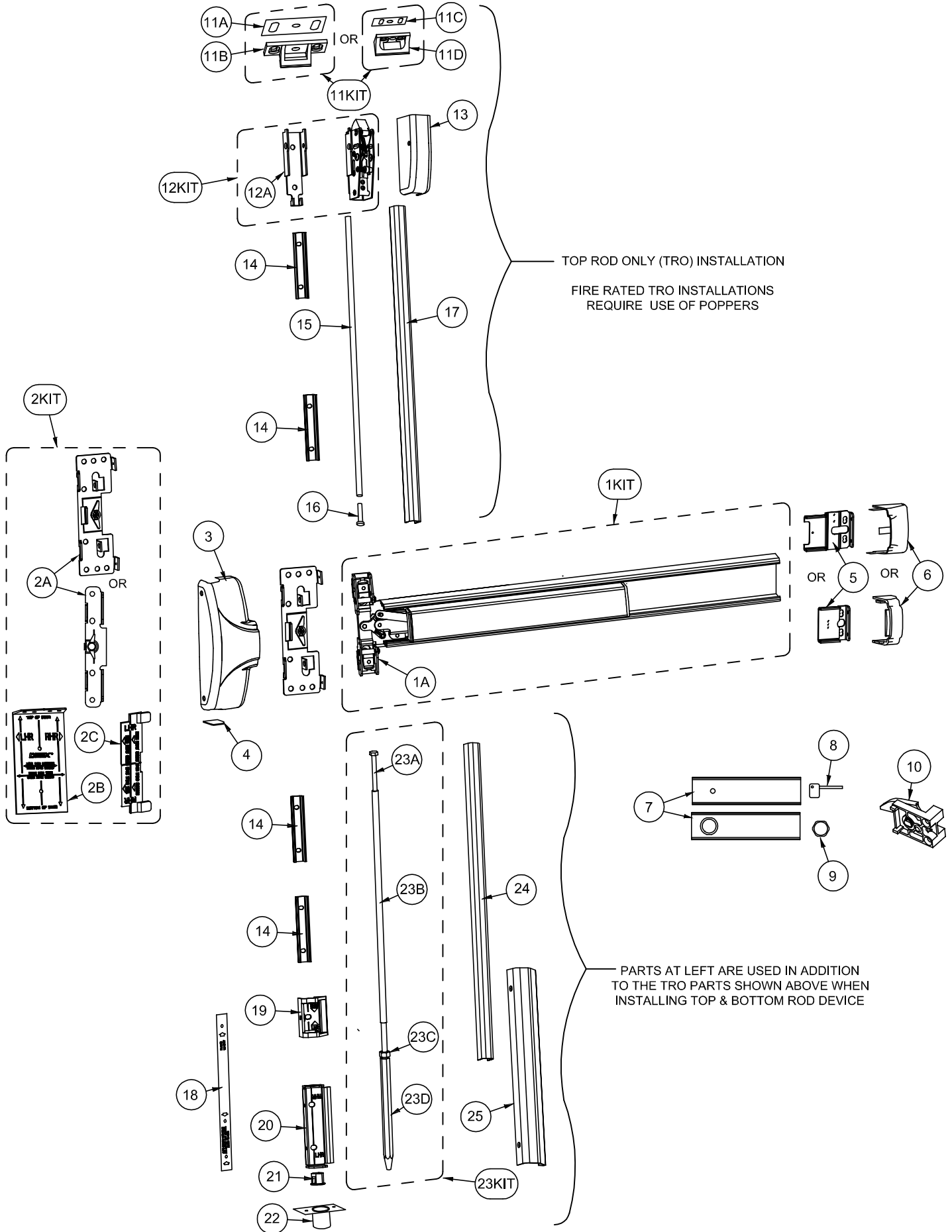
**INSTALLATION INSTRUCTIONS FOR ADVANTEX® SURFACE VERTICAL ROD  
20/21/50/51 SERIES, F20/F21/F50/F51 SERIES and "W" models (Weatherized)**

**Dwg #: 101559 (Stainless Steel)  
104690 (Aluminum)**

<b>Table of Contents</b>	<b>Page</b>
Device parts breakdown view.....	2
Device parts breakdown list with part numbers.....	3
Hardware List with part numbers & tools required.....	4
Door condition check.....	5
Use template to locate backplate.....	6
Use template to locate top strike.....	7
Use template to locate bottom bolt bracket.....	8
Use template to locate rod cover brackets.....	9
Install Pushpad assembly. Cutdown procedure (if req'd)..	10
Mortise cylinder installation (if req'd).....	11
Level/Secure Pushpad, Rehanding (if req'd).....	12
Top rod installation.....	12
Top rod installation continued / Top latch testing.....	13
Top rod cover installation.....	14
Bottom rod & Dustproof strike installation.....	15
Bottom rod cover & Centercase cover installation.....	16
Door popper & Narrow stile facia installation.....	17
Optional Accessories.....	18

**For device installation videos,  
scan code below or  
go to detex.com**



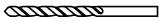





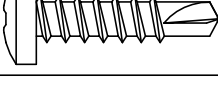
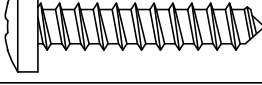
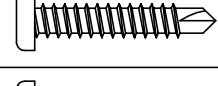




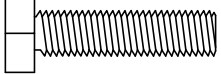
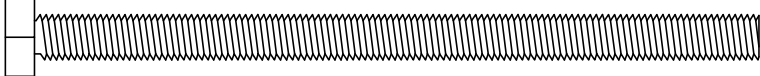
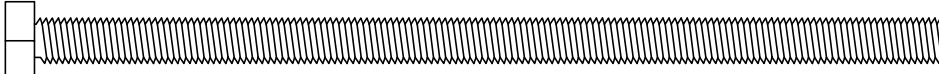

PARTS BREAKDOWN		
Item	Order Part #	Description
1KIT	105500-60	Centercase/Pushpad SubAssembly, 20 series RHR, 36", 630 (includes 1A)
	105500-61	Centercase/Pushpad SubAssembly, 50 series RHR, 36", 630 (includes 1A)
1A	101463-1	Centercase Assembly, RHR, Narrow Stile, 50 series
	101463-2	Centercase Assembly, RHR, Wide Stile, 20 series
	101463-3	Centercase Assembly, LHR, Narrow Stile, 50 series
	101463-4	Centercase Assembly, RHR, Wide Stile, 20 series
2KIT	103806-13	Mounting Plate/Strike Locator Kit, Narrow Stile (includes 2A, 2B, 2C)
	103806-10	Mounting Plate/Strike Locator Kit, Wide Stile (includes 2A, 2B, 2C)
2A	100696-1	Mounting Plate, BP2, Narrow Stile
	100697-1	Mounting Plate, BP1, Wide Stile
2B	101511-1	Strike Locator
2C	100720	Centercase Locator
3	101506-9	Centercase Cover, Stainless Steel, Wide, 20 series, 630
	101505-9	Centercase Cover, Stainless Steel, Narrow, 50 series, 630
	104640-5	Centercase Cover, Aluminum, Wide, 20 series, 628
	104602-5	Centercase Cover, Aluminum, Narrow, 50 series, 628
4	101709	Centercase Cover Cap (for TRO device only)
5	100147	Endcap bracket for EC1 (ramped) endcap w/o battery holder
	101093	Endcap bracket for EC1 (ramped) endcap w/ battery holder
	104303	Endcap bracket for EC2 (flush) endcap w/o battery holder
	104636	Endcap bracket for EC2 (flush) endcap w/ battery holder
6	101642-9	Endcap, EC1 (ramped) Stainless Steel, 630
	104304-9	Endcap, EC2 (flush) Stainless Steel, 630
	104612-1	Endcap, EC2 (flush) Aluminum, 628
7	100860-136	Fillerplate, Subassembly, S&R, Hex Dogging, HD, 20 series, 36", 630
	100860-118	Fillerplate, Subassembly, S&R, Cylinder Dogging, CD, 20 series, 36", 630
	100860-100	Fillerplate, Subassembly, S&R, Hex Dogging, HD, 20 series, 36", 628
	100860-137	Fillerplate, Subassembly, S&R, Hex Dogging, HD, 50 series, 36", 628
8	100450	Hex Key (for Hex Dogging)
9	100783	Cylinder Nut (for Cylinder Dogging)
10	102216-2	Hex Dogging Assembly
	102216	Cylinder Dogging Assembly
11KIT	100855-3	97 Strike Kit (includes 11A & 11B)
	100855-4	96 Strike Kit (includes 11C & 11D)
11A	100088	Strike Shim
11B	100234-1	Strike, Non-roller
11C	101067	Strike Shim, Narrow
11D	100330	Strike, Non-roller, Narrow
12KIT	101464	Top Latch Assembly (includes 12A)
12A	101393	Mounting Bracket, Top Latch Assembly
13	101400-9	Top Latch Cover 630
14	101425	Rod Cover Bracket
15	104051-1	Top Rod, 7' Door, Steel (36.375" long)
	104051-2	Top Rod, 8' Door, Steel (48.375" long)
16	101574-2	1/4-20 Hex Bolt, 2" long
17	101487-9	Top Rod Cover, 7' & 10' applications 630 ( x 2 FOR 10')
	101461-9	Top Rod Cover, 8' applications
18	101716	Mylar Bottom Latch Bracket Locator
19	101428	Bracket, Top (for bottom rod bolt)
20	101427	Bolt Retaining Bracket
21	101429	Hex Bushing
22	101562-9	Dust Strike
23KIT	101567	Bottom Rod Assembly (includes 23A-23D)
23A	101574-3	1/4-20 Hex Bolt, 3" long
23B	101477	Bottom Rod
23C	PP-5062-37	3/8-16 x 2 1/64 thick Hex Nut
23D	101430	Bottom Bolt
24	101486-9	Bottom Rod Cover 630
25	101426-9	Bottom Cover 630

Your particular part or configuration may not be shown:  
Contact Detex technical support at 800-729-3839 (option 2)

**Hardware Table for BASIC device mounting.  
Additional hardware is provided per the device configuration in kit  
form and is addressed on the appropriate pages as required**

**EC1 (ramped) Device hardware kit: p/n 101564-1 for Hex Dogging (HD)**  
**EC1 (ramped) Device hardware kit: p/n 101564-2 for Cylinder Dogging (CD)**  
**EC2 (flush) Device hardware kit: p/n 105724-1 for Hex Dogging (HD)**  
**EC2 (flush) Device hardware kit: p/n 105724-2 for Cylinder Dogging (CD)**

	Fastener Part No	Drill Bit 
	P/N: 100980 1/4-20 x 1" PPH	#7 or 13/64"
	P/N: 101621-5 1/4-20 x 1/4" PPH	#7 or 13/64"
	P/N: 101632-2 10-32 x 5/16" PFHU	-----
	P/N: 101950-105 8-32 x 5/16" PFHU	-----
	P/N: 100162-106 6-32 x 3/8" PFHU	-----
	P/N: 103276-63 #14 x 1" PPH SELF DRILLING	1/8 pilot hole recommended for self-drilling screws
	P/N: PP-5183-110 #14 x 1-1/4" PPH WOOD SCREW	-----
	P/N: 103276-41 #10 x 1" PPH SELF DRILLING	
	P/N: PP-5183-68 #10 x 1" PPH	-----
	P/N: PP-5067-25 #14 Lockwasher	

	P/N: 101574-1 1/4-20 x 1" BOLT
	P/N: 101574-4 1/4-20 x 4" BOLT
	P/N: 101574-5 1/4-20 x 5" BOLT
	P/N: 101574-6 1/4-20 x 6" BOLT

**Tools Required:**

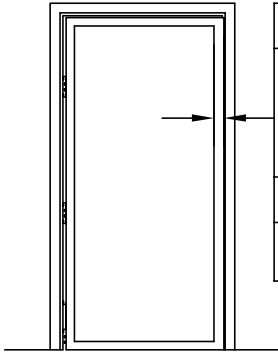
Power Drill  
Level  
Combination Square

Safety Glasses  
Pencil

Tape Measure  
Center Punch

3 /16" & 5 /32" Allen Wrenches  
#2 and #3 Phillips Screw Drivers

# !!!CHECK BEFORE STARTING!!!

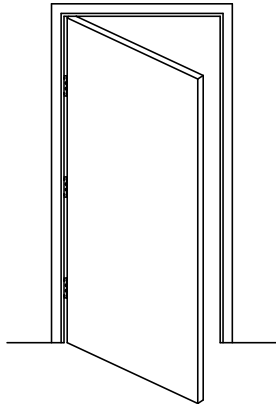
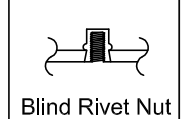
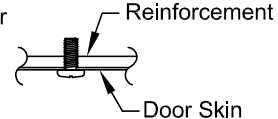


Wide Stile (Surface Strike)
Minimum door stile 4-1/2" (114 mm). Template drawings provide door and frame structural and dimensional specifications for door and frame preparation.
Narrow Stile
Minimum door stile 2" (51mm)

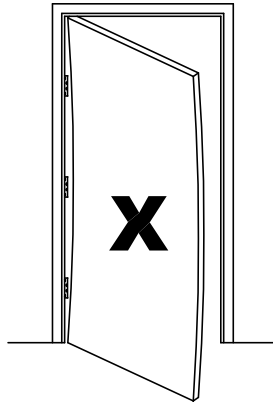
Doors and frames with walls having a structural thickness (metal skin plus reinforcement, or solid wood) to engage less than (3) full screw threads, are considered unreinforced for hardware.

Unreinforced Doors: Use Sex Nuts and Bolts  
Unreinforced Frames: Use Blind Rivet Nuts (see sketch)  
Fasteners for unreinforced openings are not supplied by Detex.

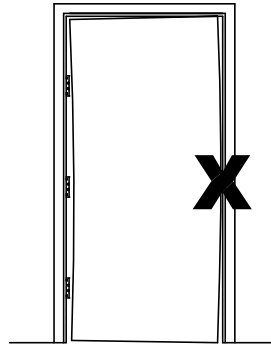
Reinforced door or frame engages at least (3) screw threads.



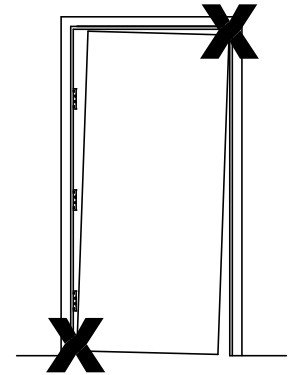
Door Must Swing Freely



Door Must Not be Warped



Door Must Not Bind



Door Must Not Sag

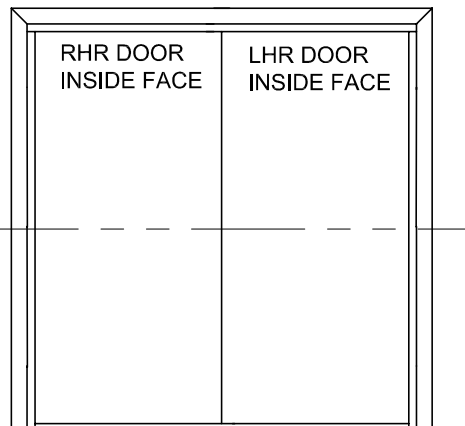
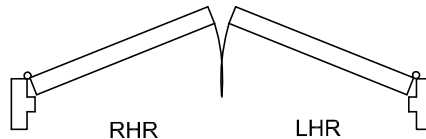
**NOTE:** 750mm MAXIMUM DOOR WIDTH OPENING FOR EUROPE FOR 36" DEVICE  
1000mm MAXIMUM DOOR WIDTH OPENING FOR EUROPE FOR 48" DEVICE

THE SAFETY FEATURES OF THIS PRODUCT ARE ESSENTIAL TO IT'S COMPLIANCE WITH EN 1125.  
NO MODIFICATION OF ANY KIND, OTHER THAN THOSE DESCRIBED IN THESE INSTRUCTIONS ARE PERMITTED.

WHEN PLACING EXIT DEVICES ON EXISTING DOORS, DETEX OFFERS SVR REINFORCEMENT KIT #101063 TO STRENGTHEN THE TOP & BOTTOM BOLT INSTALLATION

**NOTE:** LOCAL CODES MAY REQUIRE THROUGH BOLTING. SEX NUTS ARE **NOT** INCLUDED WITH THIS DEVICE. SEX NUTS CAN BE PURCHASED SEPARATELY.

Detex provides optional kits for Advantex, see last page.



## MOUNTING PLATE & STRIKE INSTALLATION:

The installation of a wide or narrow device is the same except for the mounting plate (see illustration below) and plastic locator positions when marking holes. This instruction depicts a BP1 installation unless noted otherwise.

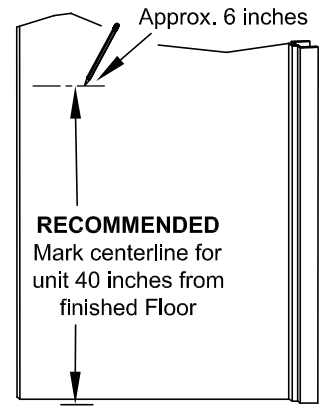
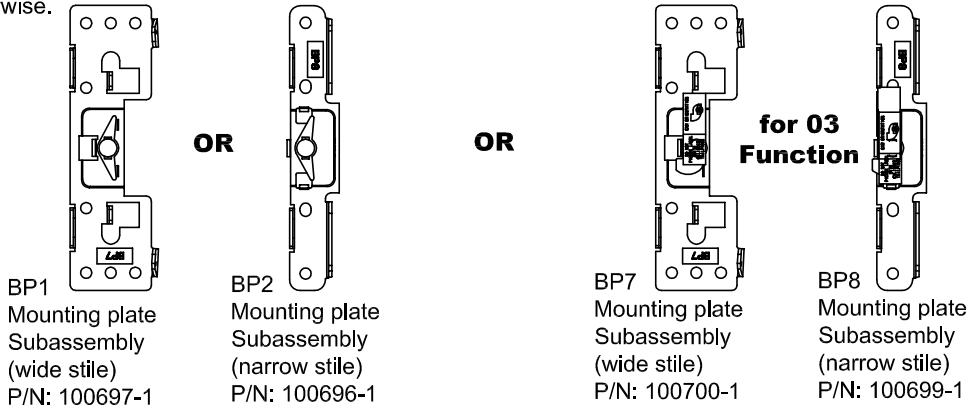


FIG. 1

MOUNTING PLATES SHOWN ABOVE FOR USE WITH LEVER TRIM

**RETROFIT NOTE: DO NOT RE-USE OLD MOUNTING PLATE!**

Slide centercase mounting plate in place on centercase locator.

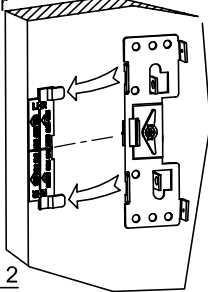


FIG. 2  
NOTE:

Centercase mounting plate located in filler/trim carton

Mark 4 holes for mounting screws (2 top & 2 bottom)

Align **EDGE** of locator with edge of door

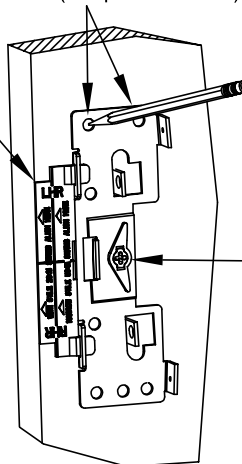


FIG. 3A  
WIDE STILE

Mark 2 holes for mounting screws (1 top & 1 bottom)

Align **INSIDE CORNER** of locator with edge of door

If trim is used, peel back label from cam, mark center hole for tailpiece, replace label

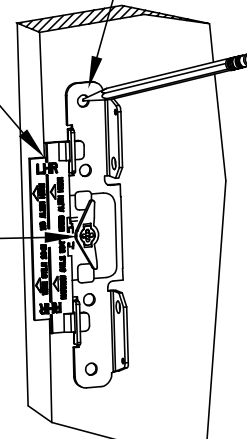


FIG. 3B  
NARROW STILE

### NOTES:

Plastic locators are provided with an extra 1/2" flap to allow better centering of the device on the stile or can be used when installing 1/2" Astragal to give equal backset from the door edge.

IF OUTSIDE TRIM IS USED, REFER TO OUTSIDE TRIM INSTRUCTIONS NOW.

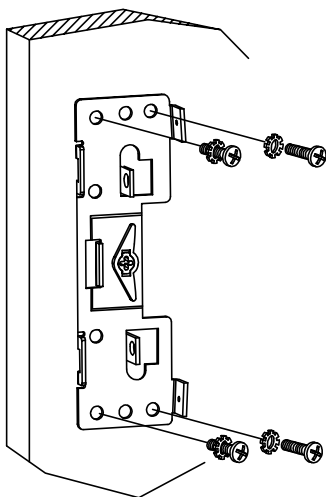
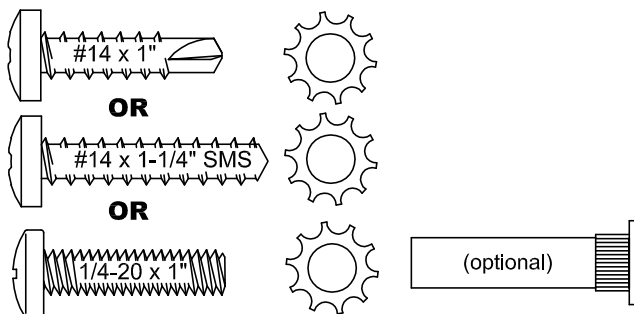
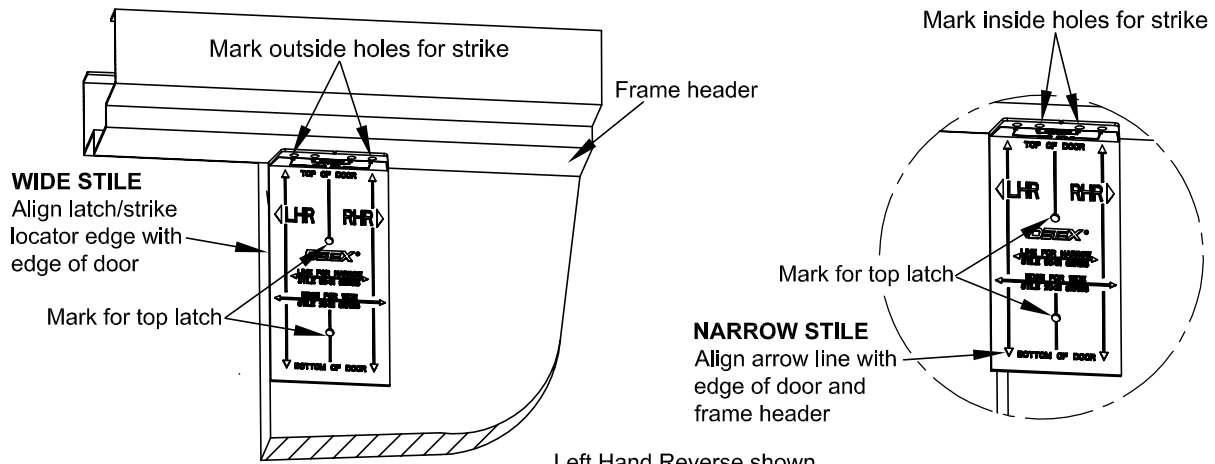


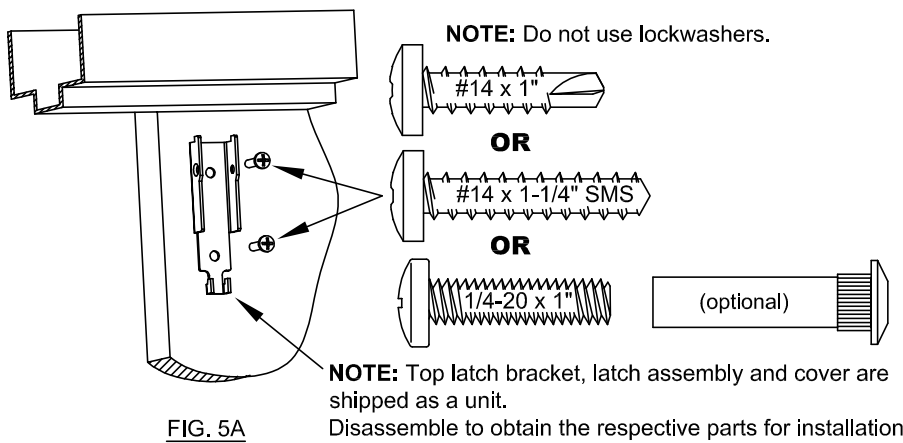
FIG. 3C



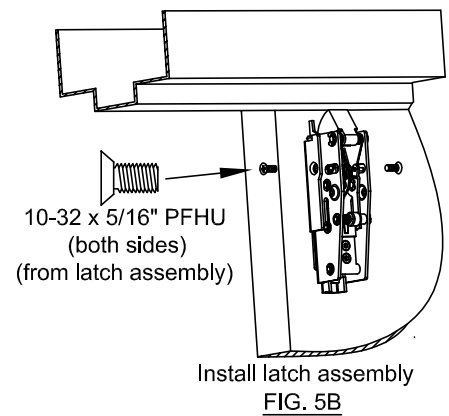


Left Hand Reverse shown

**FIG. 4**

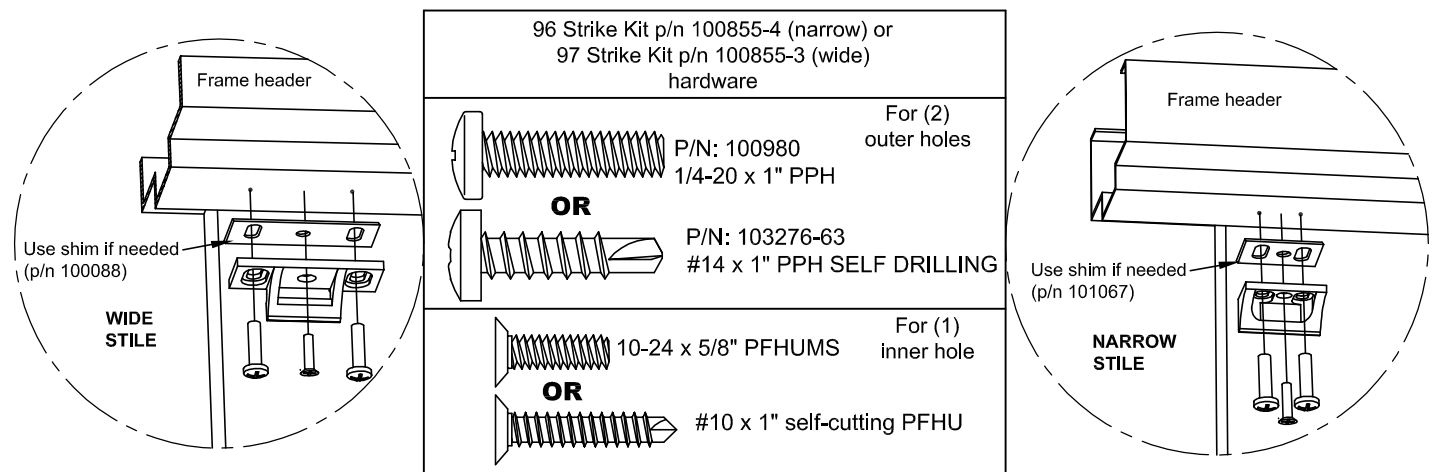


**FIG. 5A**



**FIG. 5B**

**INSTALL TOP STRIKE**

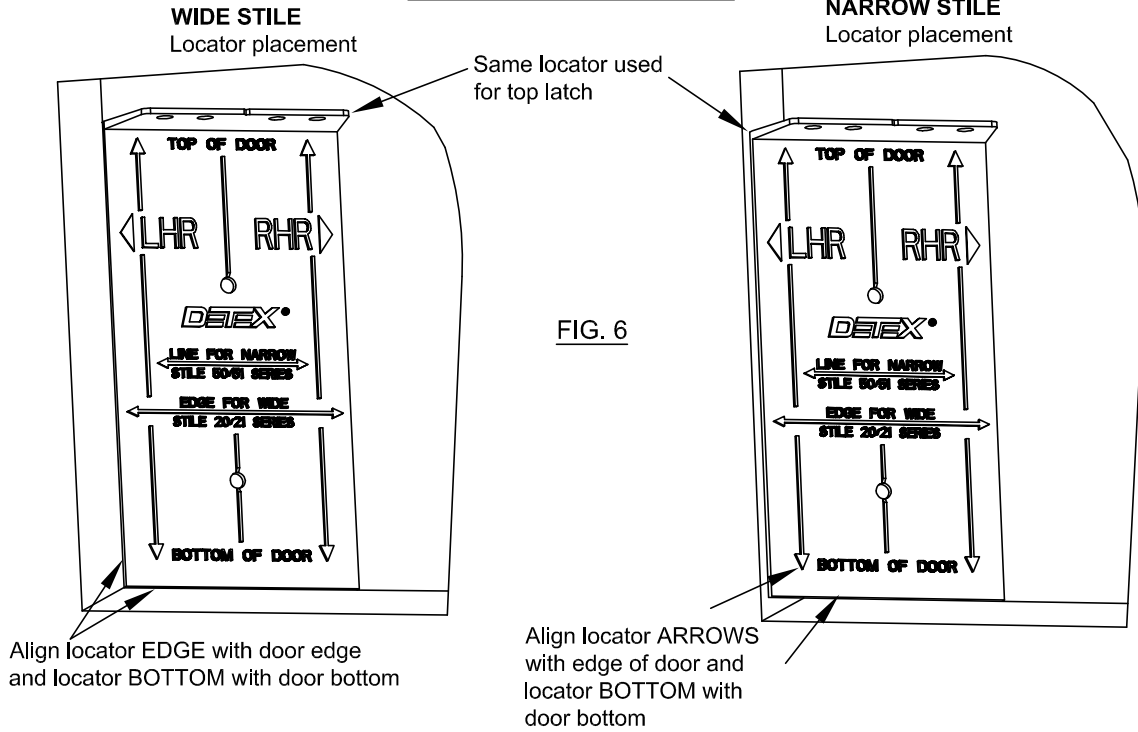


Install inner screw **AFTER** final adjustment  
(See Pg. 13 Adjustment/Troubleshooting, Note #4)

**FIG. 5C**

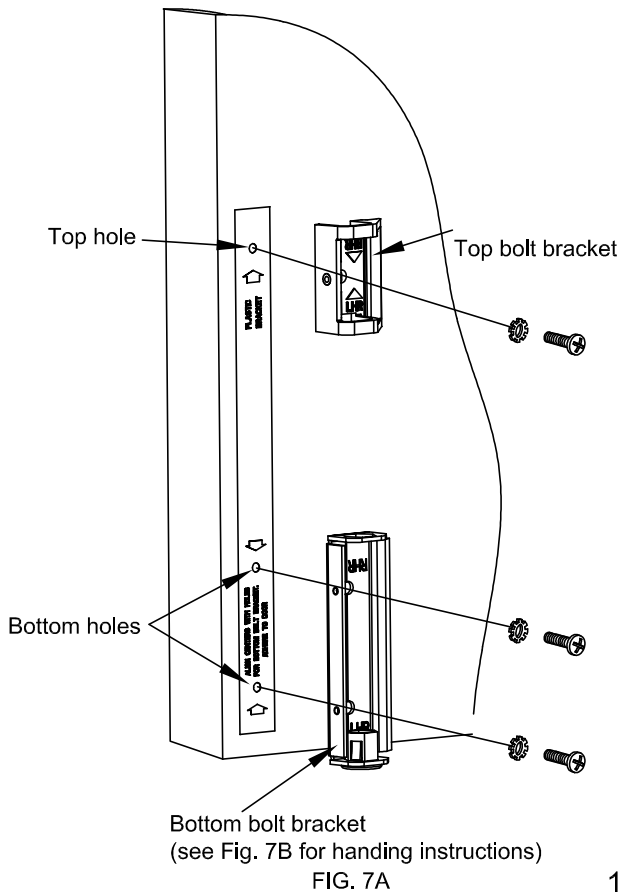
**NOTE: IF TOP ROD ONLY (TRO) DEVICE, SKIP THIS PAGE AND CONTINUE WITH INSTALLATION**

**MARK BOTTOM BOLT HOLES**



**INSTALL BOTTOM BOLT**

1. Align two bottom holes of mylar bracket locator to previously marked hole locations.
2. Adhere mylar bracket locator to door (locator may remain permanently in place).
3. Drill through top hole of mylar bracket locator.
4. Drill holes for bottom bolt bracket.



**NOTE:** Handing of bottom bolt bracket is reversible by removing hex bushing and placing in opposite end.

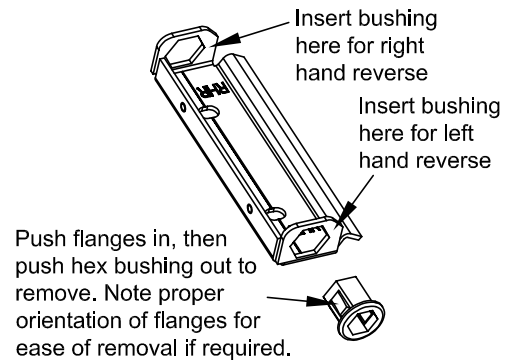
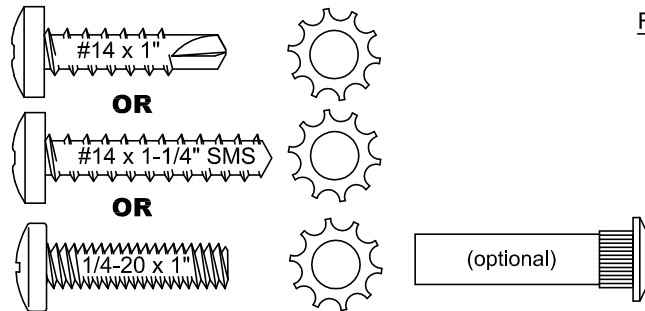


FIG. 7B





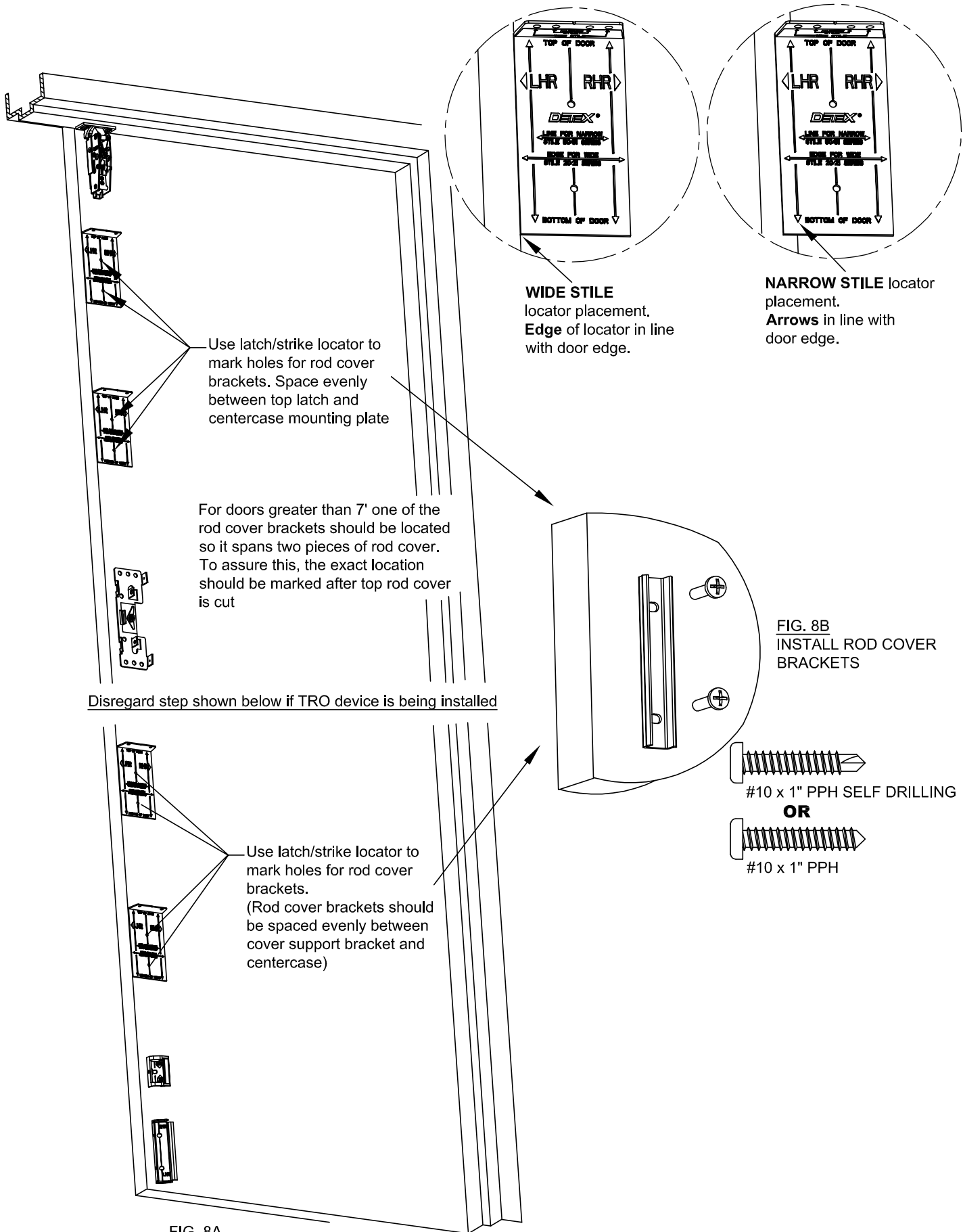


FIG. 8A

AFTER POSITIONING DEVICE AGAINST DOOR,  
 INSTALL 1/4-20 x 1/4" PPH SCREWS.  
 CAUTION: MUST INSTALL TO SECURE CENTERCASE  
 NOTE: FAILURE TO INSTALL VOIDS WARRANTY

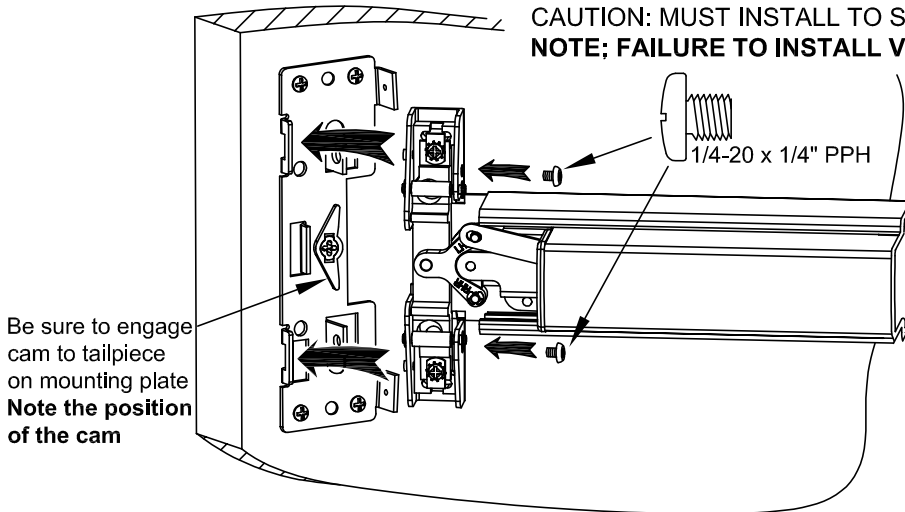


FIG. 9A

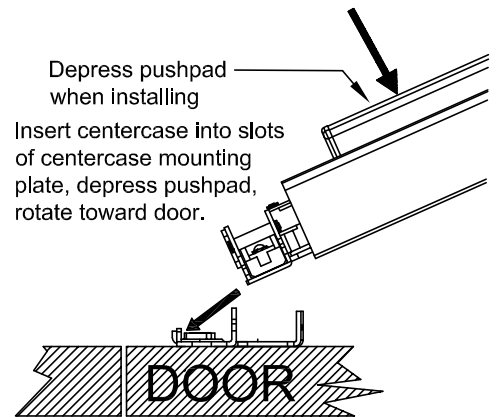
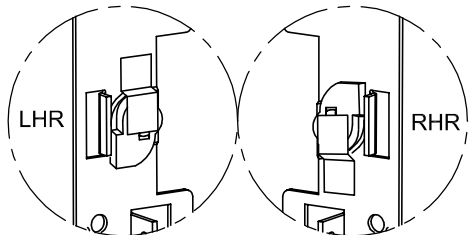
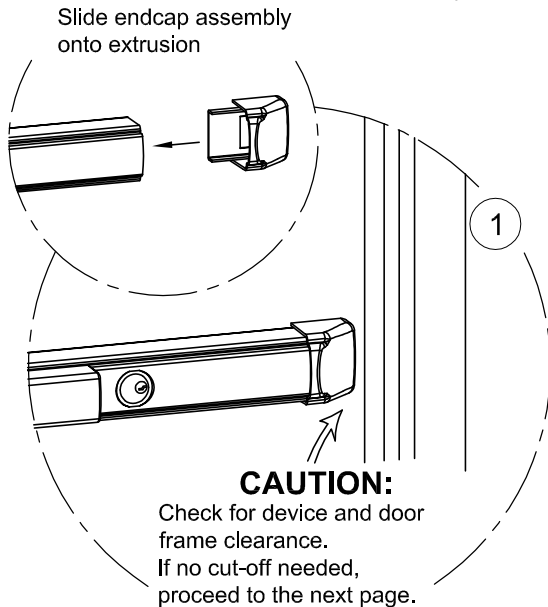


FIG. 9B

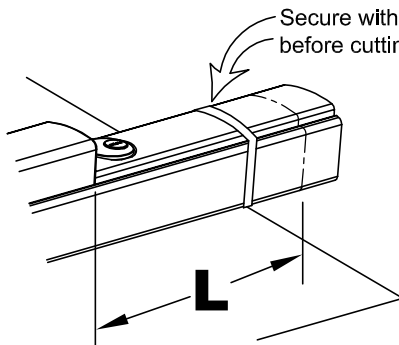


FOR 03 FUNCTION ONLY

### CHECKING FOR DEVICE CLEARANCE (Cut-Off procedure if required)



2 Cut fillerplate and extrusion STRAIGHT & SQUARE to desired length and deburr  
 Secure with tape before cutting



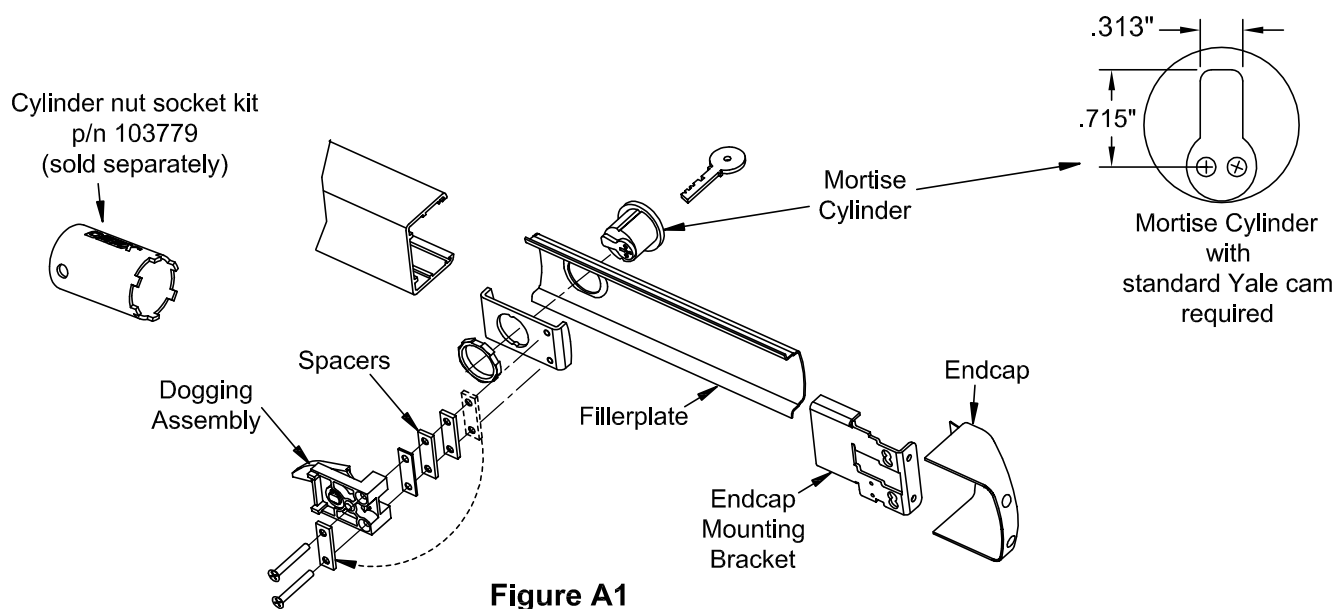
Non-Electrified Minimum Fillerplate Length	
Type	Length (L)
LD	2-1/2"
HD/CD	3"

For further Cut-Down information, see:  
[www.detex.com/cutdown](http://www.detex.com/cutdown)

For aluminum Advantex finish cutdown applications:

After cutting, the baseplate extrusion can be reversed to place the cut end inside the head cover. To do so, loosen the setscrew inside the aluminum baseplate extrusion and slide extrusion out, reverse, & slide back in. Tighten setscrew.

## MORTISE CYLINDER INSTALLATION CD (Cylinder Dogging) Cylinder Installation



Follow steps "a" through "g" for CD installations

- a. Remove endcap and endcap mounting bracket.
- b. Remove fillerplate.
- c. Remove and discard shipping insert and nut. Loosen (2) screws from dogging assembly.
- d. Install mortise cylinder (sold separately) with large hex nut provided.
- e. Trial fit dogging assembly. If cylinder is too short, remove spacers as necessary and reattach them under the (2) screw heads (See Figure A1). Fasten the (2) screws to the rest of the assembly.  
NOTE: The key should easily turn in both directions.
- f. Rotate key counterclockwise
- g. Assembly complete. Continue with Panic Hardware instruction.

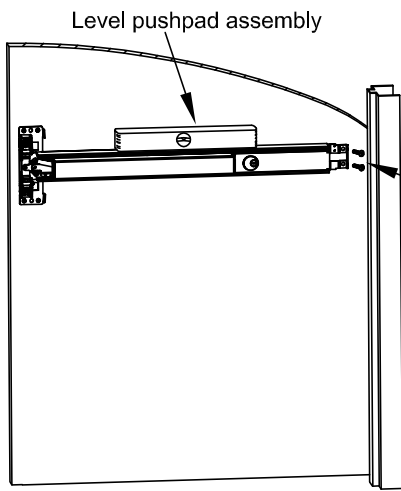


FIG. 11A

Mark and drill holes for endcap bracket.

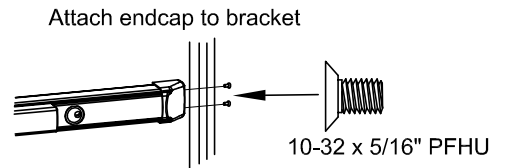
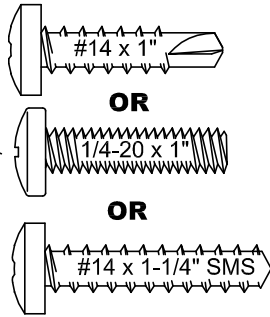


FIG. 11B

**NOTE: LINK SHOULD ALWAYS BE IN TOP POSITION**

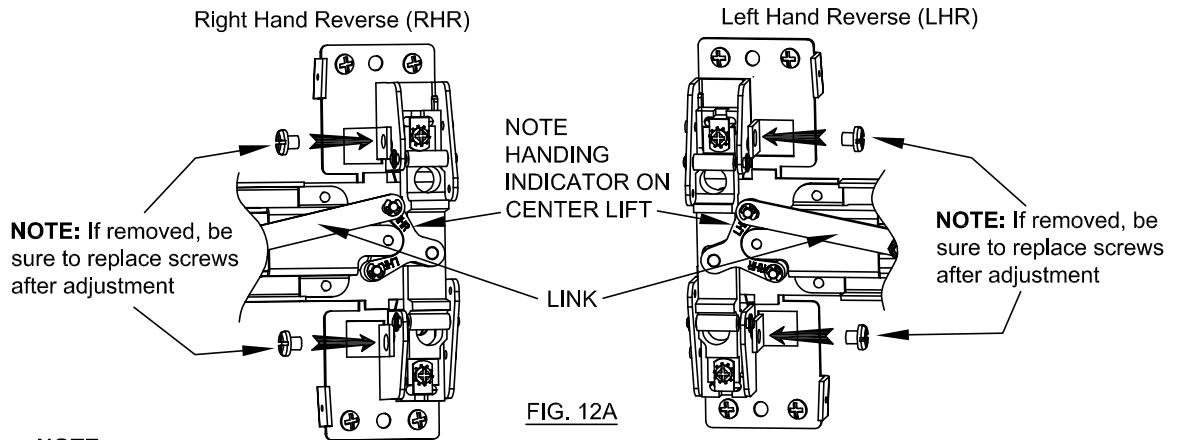


FIG. 12A

**NOTE:**

If link is not in uppermost position on the centerlift, carefully remove "E" clips and reposition link on top pin of the centerlift and replace "E" clips. (An additional "E" clip is provided on opposite link pin.)

Verify carriage moves up and down smoothly when pushpad is depressed and released.

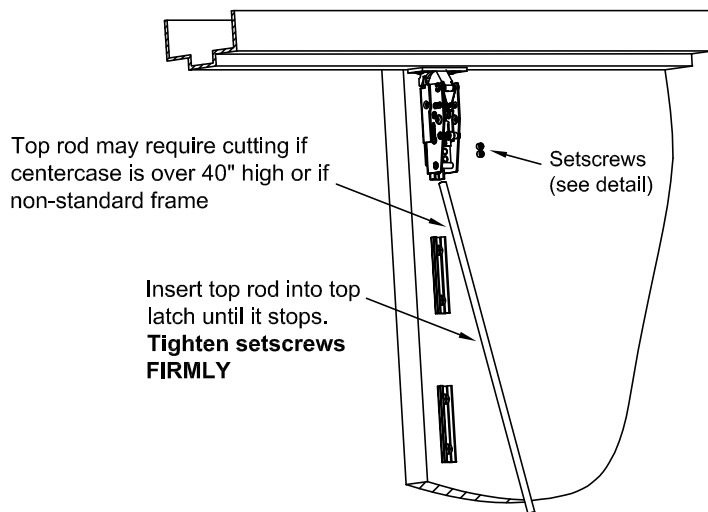


FIG. 12B

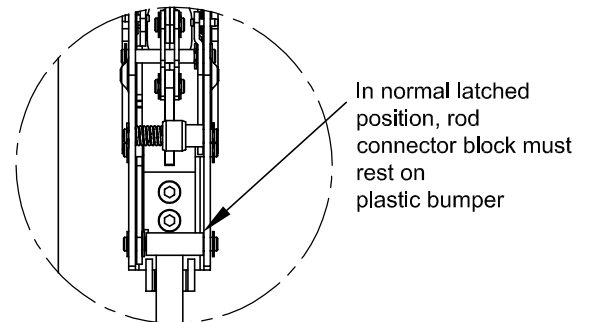
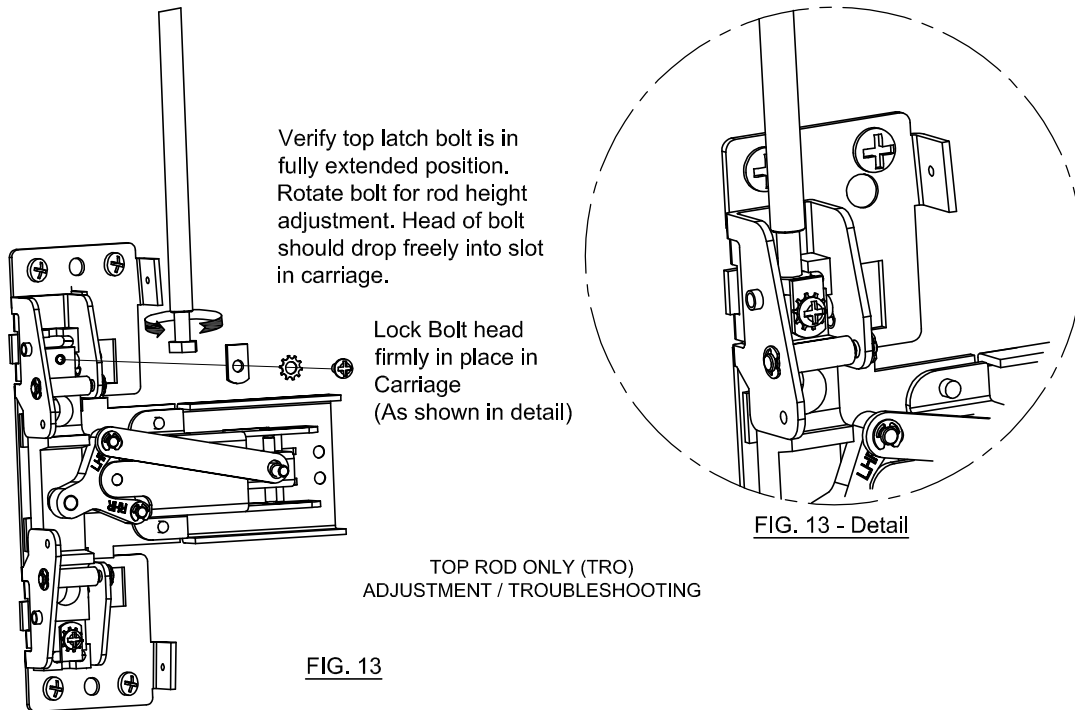


FIG. 12B  
DETAIL



#### TOP LATCH TESTING AND ADJUSTMENT

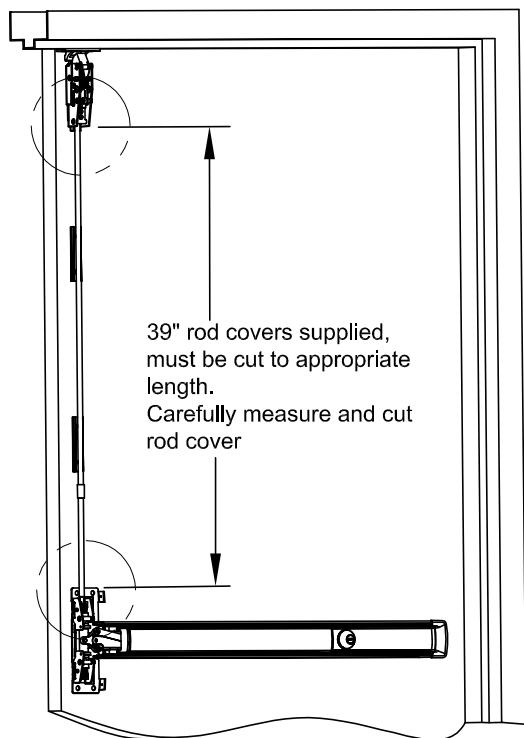
1. Close the door.  
The holdback lever should engage the backside of the strike, allowing the latchbolt to extend. The device should latch securely and latchbolt should fully project into the strike cavity.
2. Press the pushpad.  
The latchbolt should retract fully and smoothly from the strike as the door opens.
3. Release the pushpad.  
The latchbolt should remain retracted until the door is closed.
4. Once the latchbolt operation has been evaluated, the strike should be checked and adjusted to allow the door to be held snug to the frame but allow free movement of the latchbolt during normal operation. When the appropriate position has been set, a third hole should be marked, drilled and tapped for a #10 screw. Lock the strike in position with this third screw. (See Fig. 5C)

NOTE: For centerline heights significantly higher or lower than the specified 40", it may be necessary to use shorter or longer adjustment hexbolts in the rods to effect appropriate adjustment. Additional adjustment screw lengths have been packaged in the hardware kit to provide heights up to 41-1/2" and down to 36-1/2". For some door heights it may be necessary to cut the rod. Be sure to cut the un-threaded end.

#### TROUBLESHOOTING

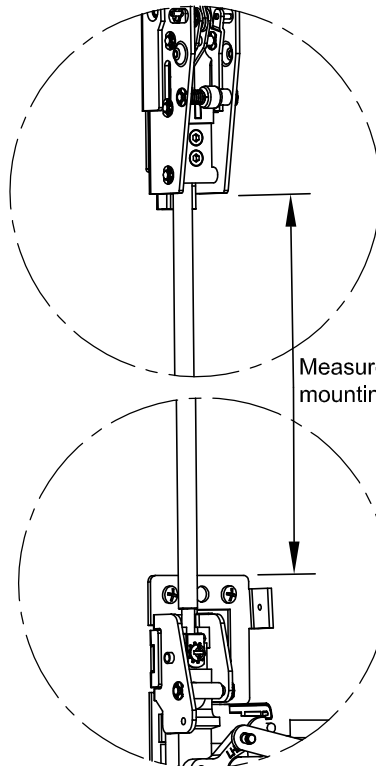
1. Latchbolt does not completely re latch when closing the door  
Loosen the strike screws and adjust the strike to allow the latchbolt to completely extend into the strike. Tighten the screws and add the third center screw to lock the strike in place.
2. Latchbolt fails to retract when pushpad is pushed  
Check centercase assembly and verify that the link is attached to the TOP post of the centerlift assembly (see Fig. 12A).
3. Latchbolt is slow or does not completely extend when door closes.  
Check position of rod dampener and move it below rod cover bracket.  
Check rod adjustment (Fig 13).  
Check centercase, verify that the 1/4-20 x 1/4" screws have been installed (See Fig. 9A).

TOP ROD COVER INSTALLATION



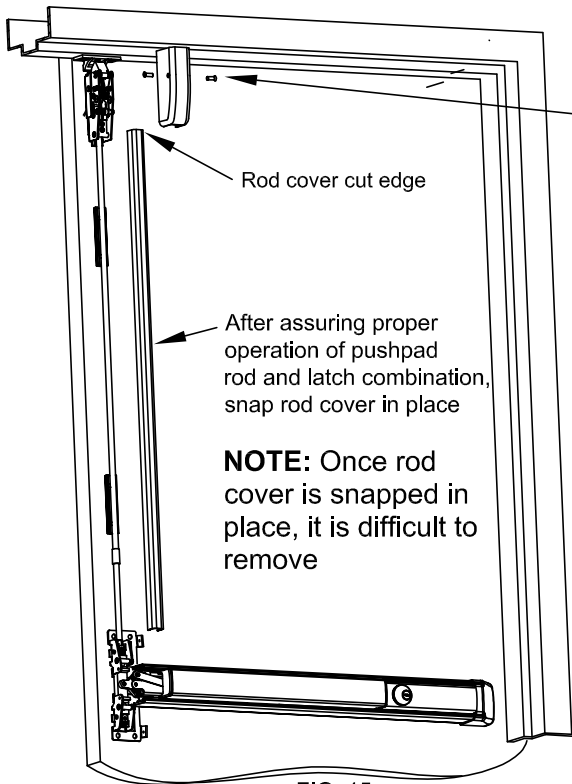
39" rod covers supplied, must be cut to appropriate length. Carefully measure and cut rod cover

FIG. 14



Measure from edge of top latch to edge of mounting plate for rod cover length

TOP COVER INSTALLATION FOR 7 FT & 8 FT DOORS



Rod cover cut edge

After assuring proper operation of pushpad rod and latch combination, snap rod cover in place

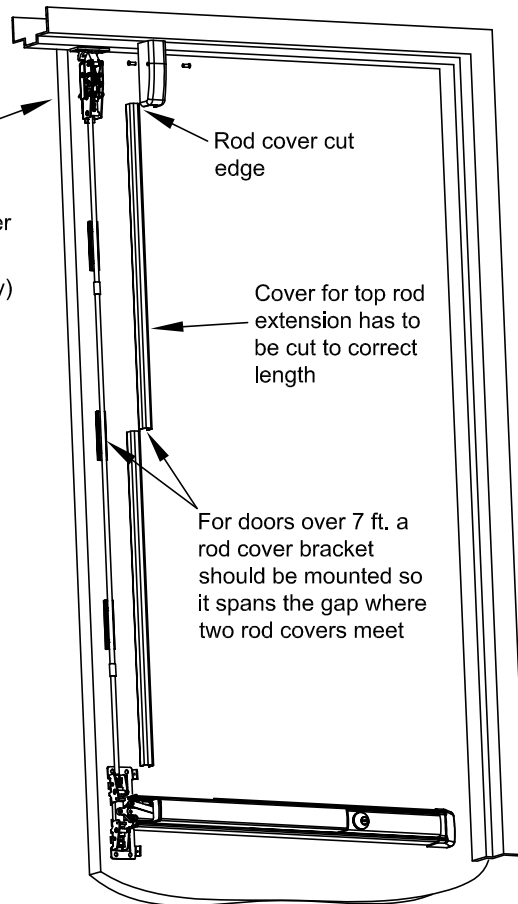
**NOTE:** Once rod cover is snapped in place, it is difficult to remove

FIG. 15

TOP COVER INSTALLATION FOR DOORS OVER 10 FT TALL



Secure top latch cover  
8-32 x 1/4" PFHU  
(from Top Latch Assy)  
Screws available in brushed chrome, oil rubbed bronze or brushed brass



Rod cover cut edge

Cover for top rod extension has to be cut to correct length

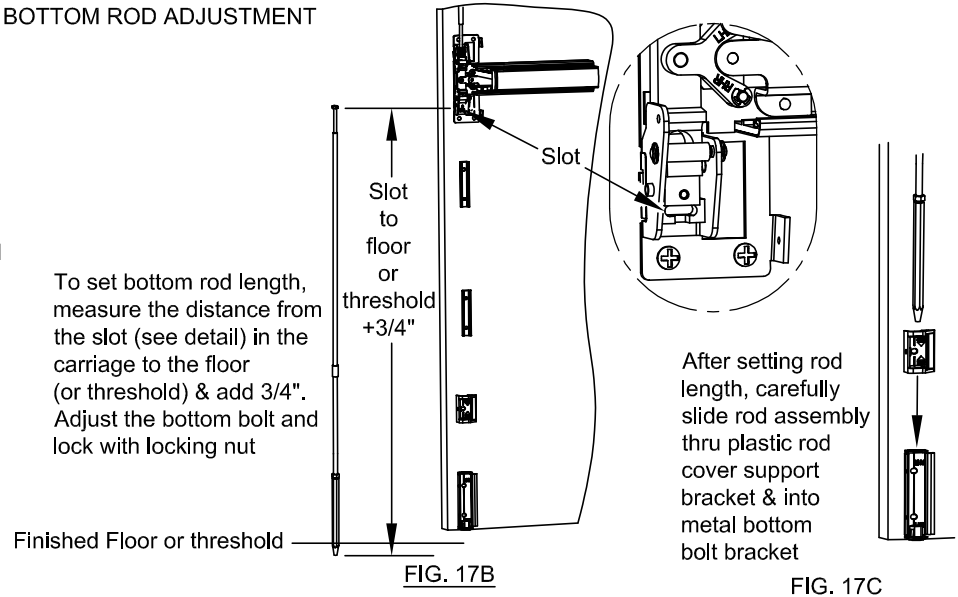
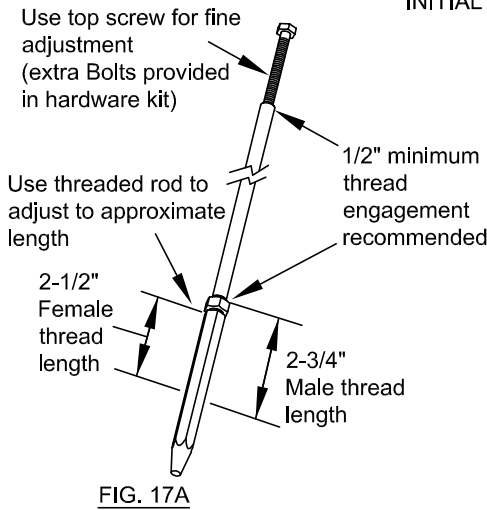
For doors over 7 ft, a rod cover bracket should be mounted so it spans the gap where two rod covers meet

FIG. 16

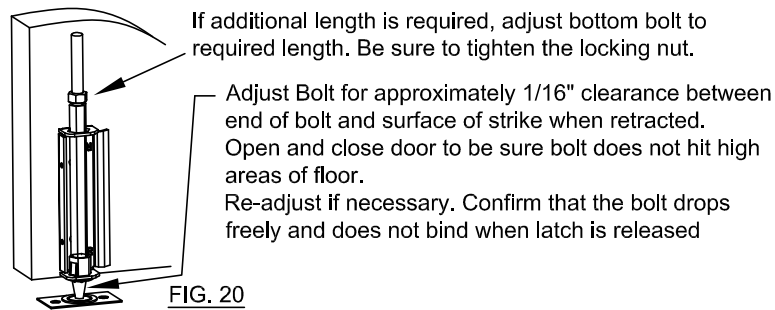
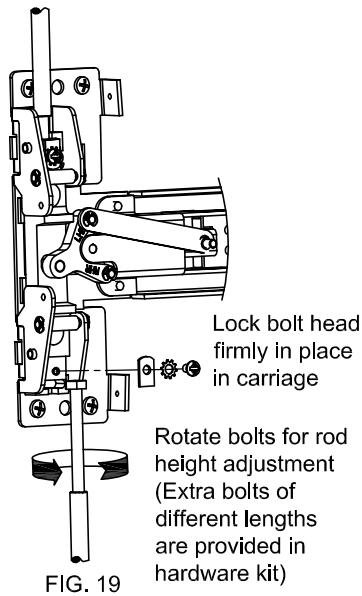
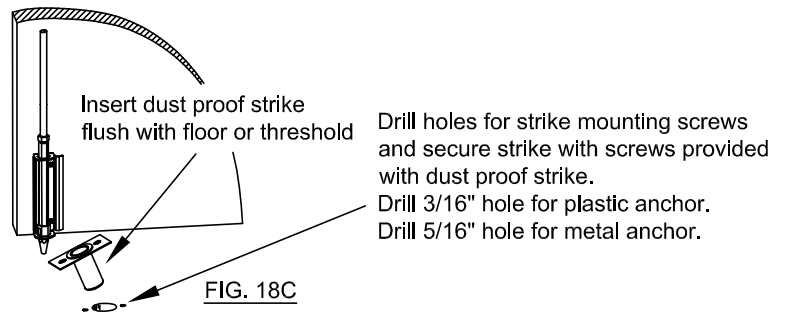
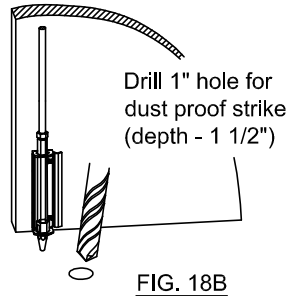
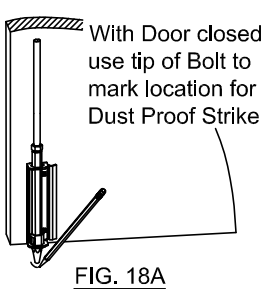
If installing a TRO device skip to Fig. 24 on page 16 and continue

**NOTE: IF TRO DEVICE, SKIP THIS PAGE AND CONTINUE TO EA SWITCH OPTION PAGE**

**INITIAL BOTTOM ROD ADJUSTMENT**



**DUST PROOF STRIKE INSTALLATION**



**BOTTOM LATCH Testing and Adjustment**

**Testing**

1. Close the door: Bolt should drop into the "dust proof strike" as the door moves into the fully closed position.
2. Press the pushpad and open the door: The bottom latch bolt should retract out of the dust proof strike and clear the strike by 1/16" to 1/8". Vertical travel of the bolt should be 3/4".
3. Release the pushpad: bolt should remain retracted until the door is closed.

**Adjustment**

1. If bottom bolt drags the floor or hits edge of dust proof strike: Loosen bolt retainer in the carriage assembly and pull bolt from carriage. Screw bolt onto bottom rod one or two turns and return it to the carriage. Test door to assure clearance and secure bolt in carriage by tightening bolt retaining plate.
2. If bolt does not completely drop when the latch is released: Check the bottom bolt bracket and be sure the bolt is aligned in the hexagonal plastic bushing. Proper alignment will allow the bolt to freely drop through the bushing.

## BOTTOM ROD COVER INSTALLATION

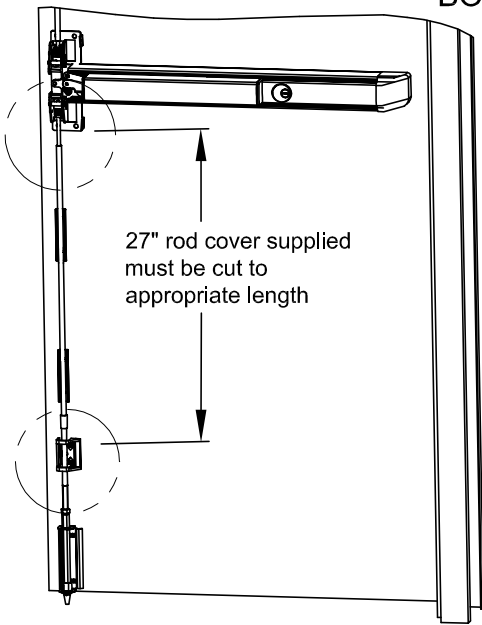
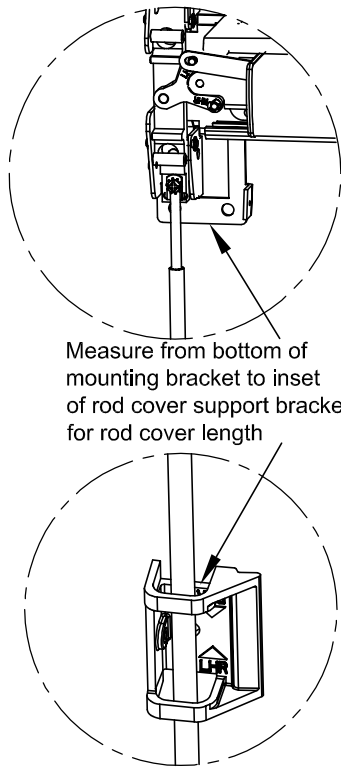


FIG. 21



Measure from bottom of mounting bracket to inset of rod cover support bracket for rod cover length

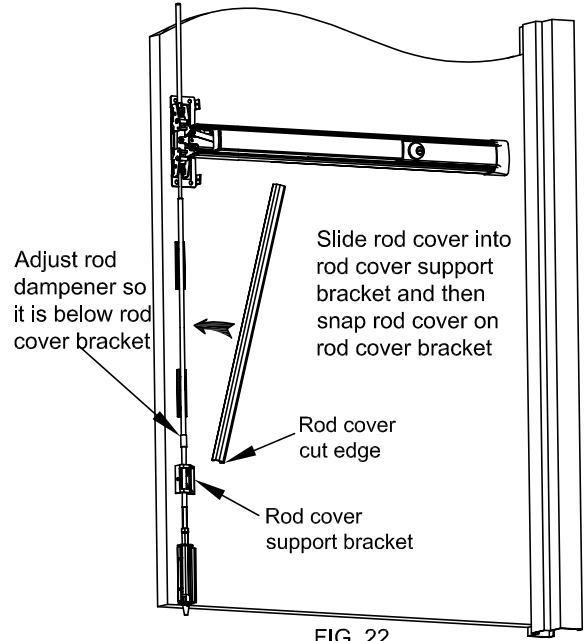


FIG. 22

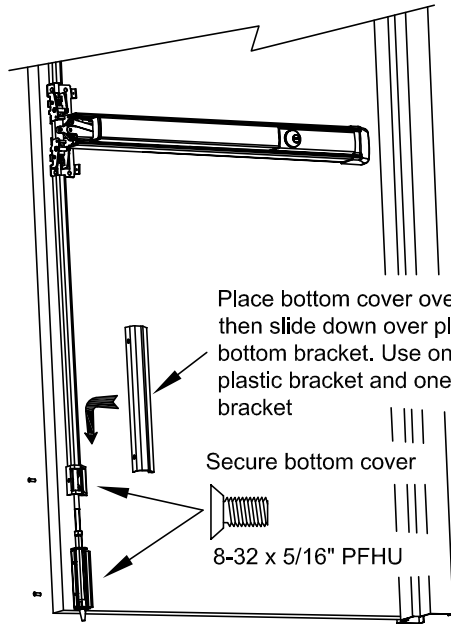


FIG. 23

Place bottom cover over rod cover then slide down over plastic and bottom bracket. Use one screw in the plastic bracket and one in the bottom bracket

Secure bottom cover

8-32 x 5/16" PFHU

## Install Centercase Cover & Sign

Install centercase cover **LAST**. Be sure edges of rod covers are not exposed.

6-32 x 3/8" PFHU

**NOTE:** TRO device requires hole cap in bottom rod cover slot (taped inside cover)

These components do **NOT** apply to TRO devices

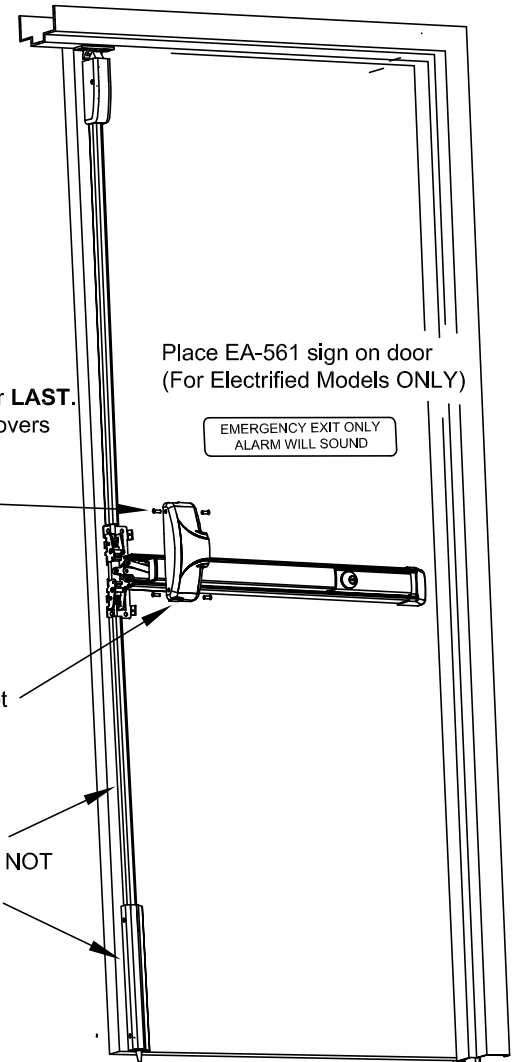


FIG. 24



## FIRE RATED TOP ROD ONLY (TRO) DOORS

A door locking popper is required when a fire door utilizes a top latching mechanism only (TRO). The popper is designed to project a spring loaded bolt into the adjacent frame or door in the event of fire. Detex recommends installing the popper in the edge of the door 12" above the threshold or finished floor. Holes for the popper and plug must be aligned with each other.

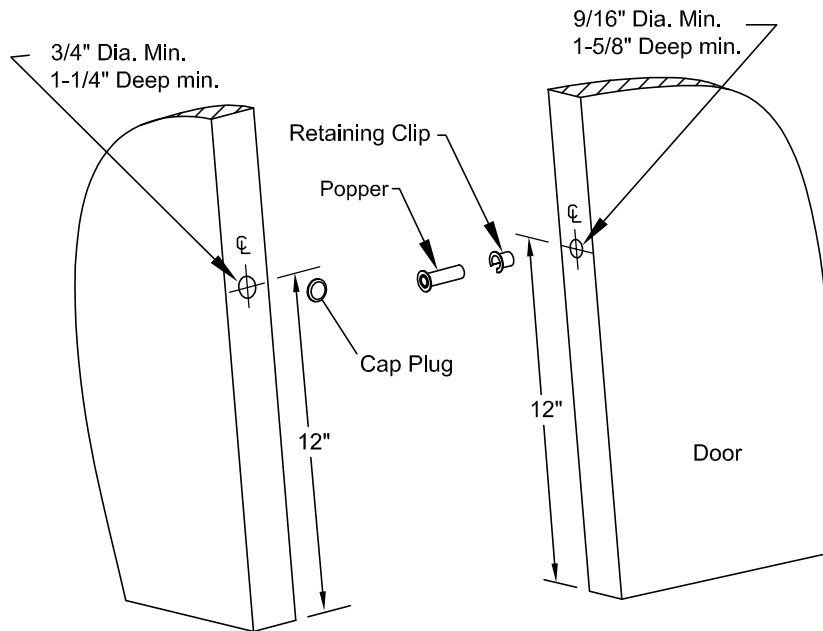


FIG. 25

NOTE: Door/Frame reinforcement is required where popper and cap plug are to be installed.

### Narrow Stile Endcap Mounting Plate Fascia (For use on Glass Doors) (not used with EC2 endcap)

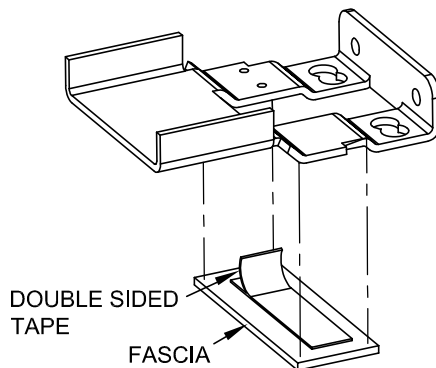


FIG. 26

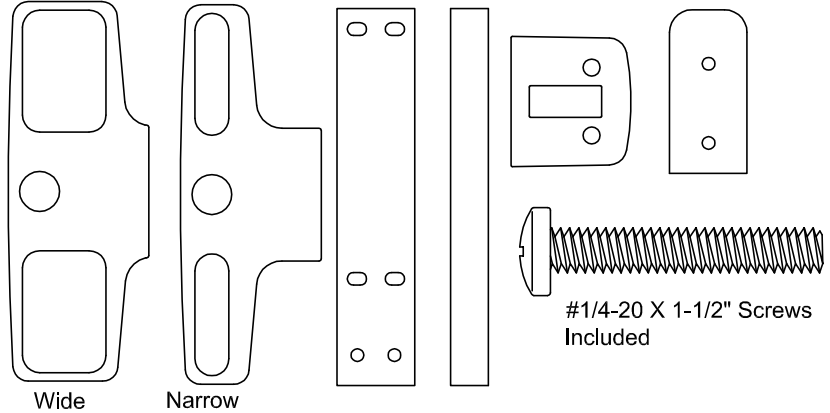
- Remove the endcap mounting bracket.
- Attach the fascia with the adhesive tape as shown in Fig. 28.
- Re-attach the endcap mounting bracket.

## Optional Accessories

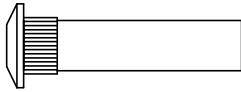
### Glass Bead Kit

#### Catalog No:

- GB3 -20 Series, 7 foot (p/n 101519-4)
- GB4 -21 Series, 7 foot (p/n 101519-1)
- GB5 -50 Series, 7 foot (p/n 101519-14)
- GB6 -51 Series, 7 foot (p/n 101519-11)
- GB7 -20 Series, 8 foot (p/n 101519-5)
- GB8 -21 Series, 8 foot (p/n 101519-2)
- GB9 -50 Series, 8 foot (p/n 101519-9)
- GB10 -51 Series, 8 foot (p/n 101519-12)
- GB11 -20 Series, 10 foot (p/n 101519-6)
- GB12 -21 Series, 10 foot (p/n 101519-3)
- GB13 -50 Series, 10 foot (p/n 101519-16)
- GB14 -51 Series, 10 foot (p/n 101519-13)



### Sex Nut



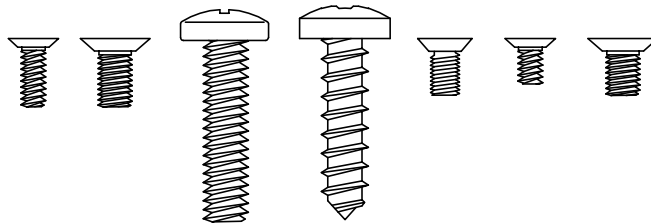
The #1/4-20 kit is available in (4) finishes:

- Catalog No: SN1 Brushed Brass BHMA 606 Finish
- Catalog No: SN1 Oil Rubbed Bronze BHMA 613 Finish
- Catalog No: SN1 Brushed Chrome BHMA 626 Finish
- Catalog No: SN1 Stainless Steel BHMA 630 Finish

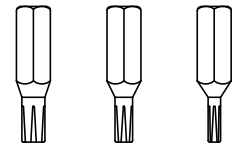
p/n: 101616-X

### Tamper Kit (Security Kit)

Catalog No: SSK2 p/n:  
101233-1



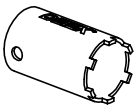
Security Screws



Security Pin TORX® Bits provided

### Cylinder nut socket

p/n: 103779



The following Models in the series were evaluated by UL: Controlled Exit Panic Devices; Model 20/21 and 50/51. These devices may be suffixed with 01, 02, 03, 08, 09, or 14 followed by C, CN, D, DN, P, PN, W, or WS followed by BP1, BP2, BP7 or BP8, followed by 605, 606, 611, 612, 613, 625, 626, 628, 629, 630, 693, 695 or 711 followed by the RHR or LHR, followed by EA, which may be followed by LD or CD, followed by 605, 606, 611, 612, 613, 625, 626, 628, 629, 630, 693, 695 or 711 followed by 96 or 97, followed by 36 or 48.