



P516-270



## CO-100

Offline lock user guide  
Instructions for CO-Series offline locks

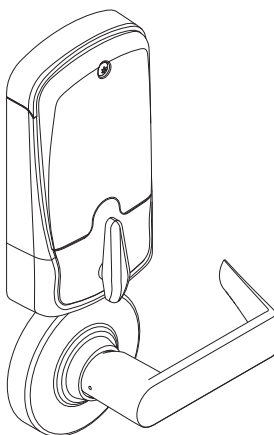
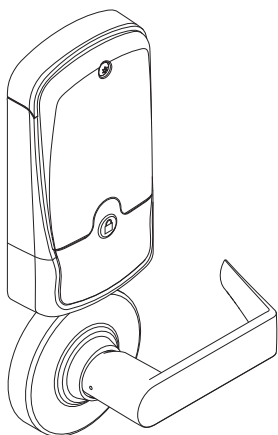
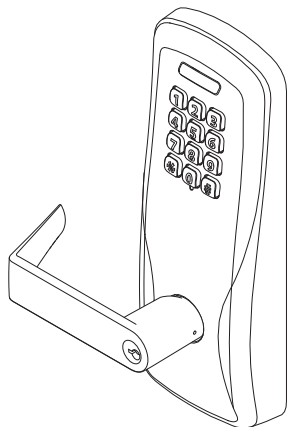

Para el idioma español, navegue hacia [www.schlage.com/support](http://www.schlage.com/support).  
Pour la portion française, veuillez consulter le site [www.schlage.com/support](http://www.schlage.com/support).

# Contents

|  |    |
|--|----|
| Overview .....                                 | 3  |
| Getting started .....                          | 4  |
| Construction access mode .....                 | 4  |
| Manual lock programming .....                  | 5  |
| Credential types .....                         | 5  |
| Programming legend .....                       | 5  |
| Manual programming commands .....              | 6  |
| Error codes .....                              | 7  |
| Test lock operation .....                      | 8  |
| Mechanical test .....                          | 8  |
| Electronic test .....                          | 8  |
| Normal lock operation .....                    | 8  |
| Lock status reports .....                      | 9  |
| Reset to factory defaults .....                | 10 |
| Batteries .....                                | 11 |
| To install or replace alkaline batteries ..... | 11 |
| Low battery indications .....                  | 11 |
| Battery failure mode .....                     | 11 |
| LED reference .....                            | 12 |
| Schlage button .....                           | 12 |
| Optional Inside Push Button (IPB) .....        | 12 |
| Troubleshooting .....                          | 12 |
| FCC Statements .....                           | 12 |

This product is compliant of UL 294 and ULCS319 standard. This product's compliance would be invalidated through the use of any add-on, expansion, memory or other module that has not yet been evaluated for compatibility for use with this UL Listed product, in accordance with the requirements of the Standards UL 294 and ULCS319. This product has been evaluated for ULC-S319 Class I.

## Overview

The Schlage CO-100 is a keypad-only off-line electronic lock in the CO-Series product line.

- This product is listed for UL294 and ULCS319.
- Two factory-configured functions are available: 1) Classroom/Storeroom, and 2) Office.
- The lock is powered by four (4) AA batteries. See *Batteries* on page 11 for more information.
- Outside lever is normally locked.
- Inside lever always allows egress.

### Outside

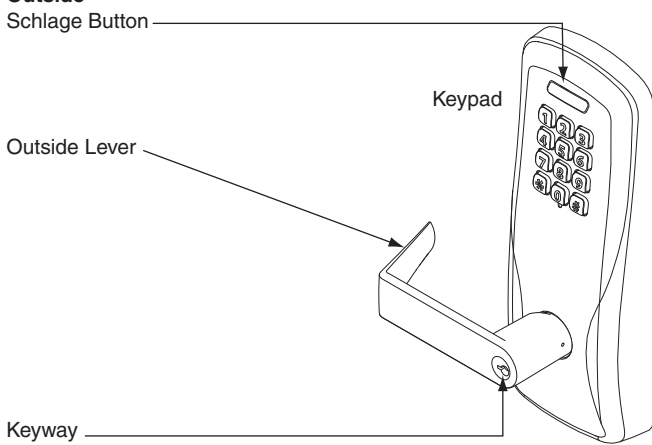

### Inside

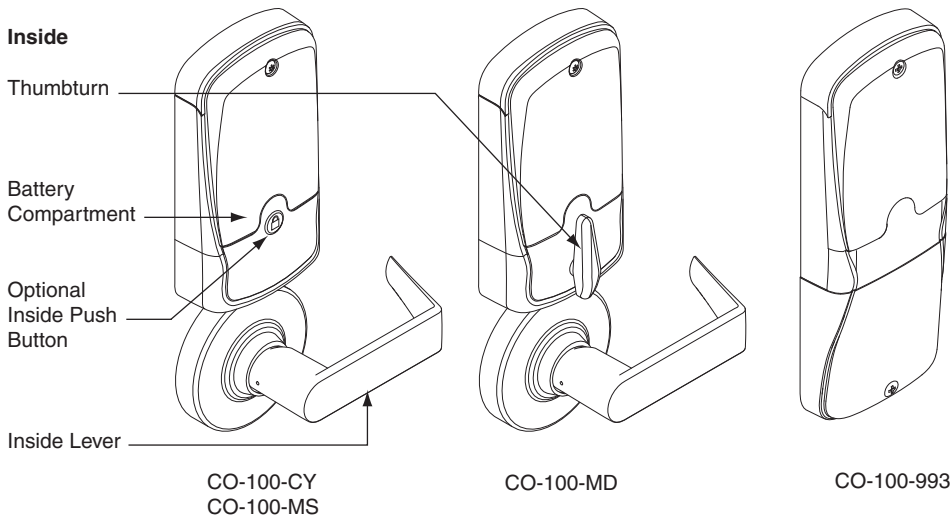

## Getting started

Follow these steps when setting up a new lock.

1. Install the lock. See the installation guide that came with the lock, or visit [www.schlage.com/support](http://www.schlage.com/support), for more information.
2. Test the lock for proper mechanical and electronic operation. See *Test lock operation* on page 8 for more information.
3. When ready to set up for normal use, enter a new programming code, then program the user credentials. See *Manual lock programming* on page 5 for more information.
4. Familiarize yourself with the information in this guide.

Save this user guide for future reference.

## Construction access mode

Construction access mode is used to allow access before the lock has been programmed, and for testing purposes. Construction access mode is enabled by default.

Offline locks with keypads have a default PIN of 13579 and “#”, which can be used for installation, testing and construction access.

- To test, enter the default PIN (13579 and “#”).
- The Schlage button will blink and the lock will unlock.
- The default PIN is automatically deleted when a new programming credential is created.

### TIP

If you press the default PIN code on a new lock and the code is not accepted, the lock has already been programmed.

If the new PIN is not known, or to put the lock back into construction access mode, reset the lock to factory settings. See *Reset to factory defaults* on page 10 for more information.

# Manual lock programming

Left LED →  ← Right LED



## Credential types

| Credential type | Function  | Description        | Default PIN |
|-----------------|---|--------------------|-------------|
| Programming     | Used to program the lock – does not unlock the lock                   | Five-digit code    | 97531 and * |
| Normal use      | Unlocks the lock momentarily  | PIN (3 - 6 digits) | 13579 and # |
| Toggle          | Changes the state of the lock unless in Freeze state                  | PIN (3 - 6 digits) |             |
| Freeze          | Maintains the lock in current state until Freeze PIN is entered again | PIN (3 - 6 digits) |             |
| Pass-Through    | Unlocks a lock momentarily, regardless of state                       | PIN (3 - 6 digits) |             |

## Programming legend







| Symbol   | Description  |
|--|--|
| [Programming Code] <sup>1</sup>  | Five-digit code, identical to programming credential code listed in the credential types table.        |
| [PIN]  | Three- to Six-digit code. A PIN can be any of the PIN code types listed in the credential types table. |
| *  | Asterisk key on the keypad   |
| 0 - 9  | Number keys on the keypad  |
|  | Schlage button   |

**TIP**  
Use the same programming code for all locks in the facility.

<sup>1</sup> Programming codes such as 1-1-1-1-1 or 1-2-3-4-5 can be easily selected by non-authorized users and should not be used.

## Manual programming commands



- ① Commands are confirmed by five alternating green blinks of the Schlage button.
- ① Programming mode will time out if no entry is made in 20-25 seconds. Timeout is indicated by red blinks of the Schlage button, three left and nine right at the same time.
- ① The right LED on the Schlage button will blink green to indicate an incorrect entry. To interpret blink patterns, refer to *Error codes* on page 7.

| Function                       | Press  | Wait For Confirmation <sup>1</sup>   |
|--------------------------------|--|--|
| Change<br>[Programming Code]   | [Programming Code] *   | Wait for<br><br>to stop flashing<br>between each<br>step.   |
|                                | 7 *  |  |
|                                | New [Programming Code] *   |  |
|                                | New [Programming Code] *   |  |
| Add Normal Use<br>PIN          | [Programming Code] *   | Wait for<br><br>to stop flashing<br>between each<br>step.   |
|                                | 3 *  |  |
|                                | ▶ New [PIN] * *  |  |
|                                | add another PIN OR * to finish   |  |
| Add Toggle PIN                 | [Programming Code] *   | Wait for<br><br>to stop flashing<br>between each<br>step.   |
|                                | 3 3 *  |  |
|                                | 1 9 1 *  |  |
|                                | ▶ New [PIN] * *  |  |
| add another PIN OR * to finish |  |  |
| Add Freeze PIN                 | [Programming Code] *   | Wait for<br><br>to stop flashing<br>between each<br>step.   |
|                                | 3 3 *  |  |
|                                | 1 1 5 *  |  |
|                                | ▶ New [PIN] * *  |  |
| add another PIN OR * to finish |  |  |
| Add Pass-Through<br>PIN        | [Programming Code] *   | Wait for<br><br>to stop flashing<br>between each<br>step.  |
|                                | 3 3 *  |  |
|                                | 1 1 9 *  |  |
|                                | ▶ New [PIN] * *  |  |
| add another PIN OR * to finish |  |  |
| Delete a PIN                   | [Programming Code] *   | Wait for<br><br>to stop flashing<br>between each<br>step. |
|                                | 5 *  |  |
|                                | [PIN] to be deleted *  |  |
|                                | * to finish  |  |
| Change Relock<br>Time          | [Programming Code] *   | Wait for<br><br>to stop flashing<br>between each<br>step. |
|                                | 9 9 *  |  |
|                                | 1 *  |  |
|                                | Each button press adds to the total delay time<br>Example: ① + ⑨ adds a 10 second delay<br>* to finish |  |

<sup>1</sup> Other lights may show before the final confirmation. Wait for final confirmation before continuing to the next step.  
<sup>2</sup> Change PIN length is available with firmware version 2.5.0 or higher.

## Manual programming commands

- ① Commands are confirmed by five alternating green blinks of the Schlage button.
- ① Programming mode will time out if no entry is made in 20-25 seconds. Timeout is indicated by red blinks of the Schlage button, three left and nine right at the same time.
- ① The right LED on the Schlage button will blink green to indicate an incorrect entry. To interpret blink patterns, refer to *Error codes* on page 7.

| Function   | Press   | Wait For Confirmation <sup>1</sup>   |
|--|---|--|
| Disable/Enable Beeper  | [Programming Code] (*)                                    | Wait for  to stop flashing between each step. |
|  | 9 9 *   |  |
|  | 3 *   |  |
|  | 0 * to disable beeper OR 7 * to enable beeper             |  |
| Change PIN Length <sup>2</sup>   | [Programming Code] (*)                                    | Wait for  to stop flashing between each step. |
|  | 9 9 *   |  |
|  | 4 *   |  |
|  | Press 3, 4, 5, OR 6 for desired PIN length<br>* to finish |  |
| <p>1 Other lights may show before the final confirmation. Wait for final confirmation before continuing to the next step.</p> <p>2 Change PIN length is available with firmware version 2.5.0 or higher.</p> |   |  |

## Error codes

- ① All error codes are indicated on the Schlage button by a solid red LED and a blinking green LED. The number of green blinks indicates the error code.

| Number of green blinks | Error code description   |
|------------------------|--|
| 1                      | Computer programming error (not complete).   |
| 2                      | Too long programming/user code entered. Programming code must be five (5) digits. User code length cannot exceed eight (8) digits. |
| 3                      | Memory full, too many codes. Delete some codes.  |
| 4                      | Programming code cannot be deleted, only changed.  |
| 5                      | Programming code entries do not match. Programming code not changed.   |
| 6                      | Invalid command. Invalid function code entered.  |
| 7                      | Code not found.  |
| 8                      | Code too short. Programming code length must be five (5) digits. User code minimum length is three (3) digits.                     |
| 9                      | Not a unique code.   |
| 10                     | Manual programming not allowed.  |

Error code functions have not been verified by Underwriters Laboratories Inc.

## Test lock operation

If you encounter problems while performing any of the following tests, review the installation guide and correct any problems.

### Mechanical test

1. Rotate the inside lever or depress the push bar to open the door. Operation should be smooth, and the latch should retract.
2. Insert the key into the keyway and rotate the key and the outside lever to open the door. Operation should be smooth, and the latch should retract.

### Electronic test

1. Press any number key. The lock will beep. Use the default PIN (13579 and “#”) to verify access.

## Normal lock operation

After PIN credentials have been programmed, enter a PIN to operate the lock as follows:

| Credential        | Action                                  |
|-------------------|---|
| Press a valid PIN | Green LED will blink and access granted |

- ① **The “#” key is used as ENTER key for PINs with fewer than six digits. Default minimum digits is six (6). PIN length may be manually configured so users do not have to push the “#” key (see *Change PIN Length2 on page 7*).**
- ① **If the PIN credential is entered incorrectly, press “\*” to start over.**



## Lock status reports

Follow the steps below to obtain lock status reports:

- ① **Lock status reporting is available with firmware version 2.5.0 or higher.**
- ① **The left and right Schlage button LEDs will blink red once with each button press, followed by the status indicator as described below.**

| Function/<br>Report  | Press   | Indicator/Report result  |
|----------------------|---|--|
| Initiate report mode | Press and hold<br><br>while pressing 9 9 # | Wait until only the right Schlage button LED is on to indicate the lock is in report mode and awaiting an entry. If no entry is made, then timeout will occur in 20 seconds. |
| Battery status       | ①   | Left LED:<br>Solid green = excellent<br>Blinking green = good<br>Blinking red = low<br>No indicator = critical battery   |

**Once a status is reported, both left and right LEDs will light green, followed by solid green on the right LED only. The right green LED indicates the lock is awaiting another entry.**

**Obtain an additional status report as described below, or press \* \* to exit report mode.**

| Function/<br>Report | Press | Indicator/Report result  |
|---------------------|-------|--|
| Firmware status     | ③     | Left LED blinks green for the version number   |
| Hardware status     | ④     | Decimal point is indicated by one red blink<br>“Zero” is indicated by two red blinks   |
| PCB serial number   | ⑥     | Left LED blinks green for each number<br>Each number is separated by two red blinks<br>Press # after two red blinks to display the next number |

**If no entry is made within 20 seconds of the solid green right LED, then timeout will occur.**

**To exit report mode at any time, press \* \* .**

## Reset to factory defaults

All information in the main controller in the lock will be deleted and reset to factory defaults!

Main controller configurations that will reset to factory default include: programming and user codes.

The door must be locked (not toggled open or in the middle of normal access) before resetting to factory defaults.

Follow these steps to reset to factory defaults.

1. Remove the top inside cover.
2. Remove one battery from the battery pack to disrupt power. Wait 5 to 10 seconds for power to run out in the lock.
3. Press and hold the Schlage button while reconnecting the battery into the battery pack to resupply power.
4. Continue holding the Schlage button, and wait for two beeps to sound and two green blinks of the Schlage button.
5. Release the Schlage button.
6. Press and release the Schlage button three (3) times within 10 seconds of the beeps and blinks at step 4. One beep will sound and one red blink will occur with each press.
7. The Schlage button will light green for one second and a one-second beep will sound, indicating that the lock has been reset.

① **If the Schlage button is not pressed 3 times within 10 seconds, two beeps and two red blinks indicate timeout.**

8. Replace the top inside cover.

To test, enter 13579 and “#”. The Schlage button will blink and the lock will unlock momentarily.

## To install or replace alkaline batteries

### ① Changing batteries does not affect any programmed data.

1. Remove the battery cover.
2. Remove the battery bracket. Do not allow the battery pack to hang from the wires.
3. Install the new batteries (install only new AA Alkaline batteries). Make sure the batteries are installed in the correct orientation.
4. Reinstall the battery pack and battery bracket.
5. Reinstall the battery cover, making sure the plug is to the right of the battery pack (CY, MS and MD locks). **Be careful not to pinch the battery wires when installing the battery cover.**

**CAUTION! Danger of explosion if batteries are incorrectly replaced! Replace only with new AA alkaline batteries. Dispose of used batteries according to the manufacturer's instructions.**

This product has been evaluated for ULC-S319 compliance with Duracell Procell PC1500 AA alkaline batteries and Panasonic CR2025 lithium coin cell. For installations requiring ULC-S319, these battery models should be used.

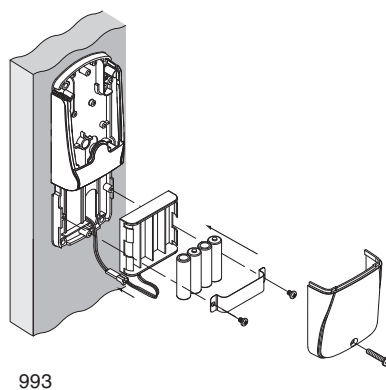
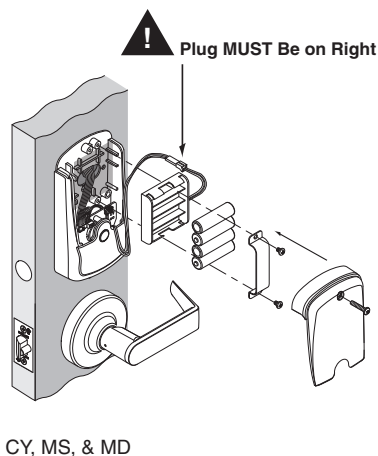

## Low battery indications

| Condition       | Indicator   | Solution   |
|-----------------|---|--|
| Batteries low   | After credential PIN is pressed, 9 red blinks of Schlage button, then normal indicator. | Replace batteries immediately to avoid battery failure. Lock is intended to operate for 500 cycles in low battery condition. |
| Battery failure | No LED or beeps<br>Valid credentials do not grant access                                | Replace batteries immediately. Mechanical override key must be used to unlock the lock.                                      |

## Battery failure mode

In the event of battery failure, the lock will fail As-Is (lock remains in current state, locked or unlocked, until batteries are replaced).

## LED reference

### Schlage button

| Condition                                   | Lights                                      |
|---|---|
| Access denied                               | 2 red blinks                                |
| Valid PIN entered while lock in Freeze mode | 12 red blinks indicating lockout            |
| Factory default reset                       | One-second solid green with one-second beep |
| Low battery indicator, AA batteries         | 9 left red blinks                           |
| Momentary unsecured access                  | 1 green blink, then one red blink on relock |

### Optional Inside Push Button (IPB)

| Action                           | Lights        |
|----------------------------------|---------------|
| Office Mode                      |               |
| Press IPB to lock                | 1 red blink   |
| Press IPB to unlock <sup>1</sup> | 1 green blink |

<sup>1</sup> Unlocking the lock with the IPB will cause the lock to remain unlocked until the IPB is depressed again.

## Troubleshooting

| Problem   | Possible cause  | Solution   |
|---|---|--|
| The lock does not function when a valid PIN credential is entered, or the lock beeper does not sound. | The beeper may be turned off.   | Use manual programming to enable the beeper (see <i>Disable/Enable Beeper</i> on page 7).  |
|   | The battery or wired power may be improperly connected.   | Check that the battery or wired power is connected correctly.  |
|   | The batteries may be inserted with incorrect polarity.  | Check that batteries are inserted in the correct polarity.   |
|   | The batteries may be depleted.  | Replace batteries.   |
|   | If applicable, the IPB through-door ribbon cable may not be properly plugged in, or may have bent pins. | Check that the optional IPB through-door ribbon cable is plugged in correctly (if applicable). The red wire should be on the left and not pinched in the door.<br>Check that there are no bent pins on the optional IPB through-door cable.<br><i>Refer to the installation instructions that came with the CO-100 lock, or this user guide for details on the above mentioned procedures.</i> |

## FCC Statements



This device complies with Part 15 of the FCC Rules. Operation is subject to the following two conditions:

1. this device may not cause harmful interference, and
2. this device must accept any interference received, including interference that may cause undesired operation.

### Customer Service

1-877-671-7011 [www.allegion.com/us](http://www.allegion.com/us)



ALLEGION

© Allegion 2014  
Printed in U.S.A.  
P516-270 Rev. 03/14-e

11.000"

5.500"

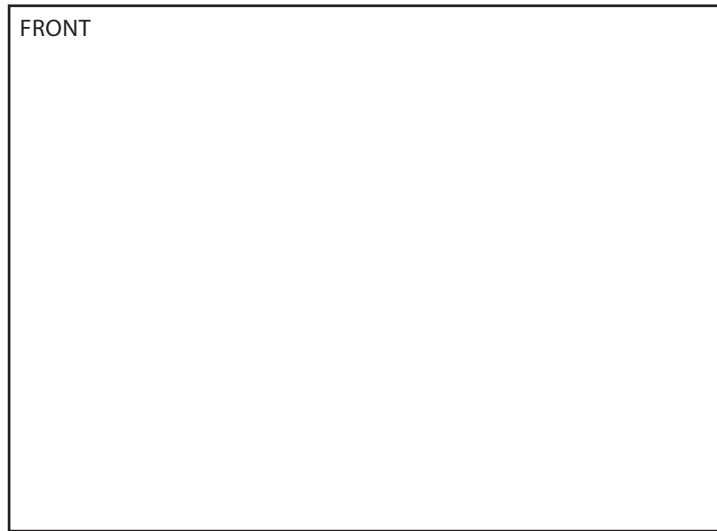

8.500"

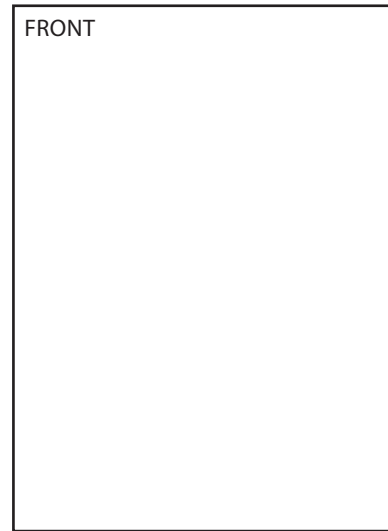

8.500"

BEGINNING SHEET

FOLDED SHEET

|                                    |
|------------------------------------|
| Additional Notes:                  |
| 1. Booklet Format, Center Stitched |

|                                    |        |        |        |       |   |   |  |  |  |                 |              |
|------------------------------------|--------|--------|--------|-------|---|---|--|--|--|-----------------|--------------|
| Revision History                   |        |        |        |       |   | Revision Description:<br>E > Revise SH2 artwork |  |  |  |                 |              |
| A                                  | B      | C      | D      | E     | F |   |  |  |  |                 |              |
| 013619                             | 014686 | 020195 | 028472 | 48533 |   |   |  |  |  |                 |              |
| Material                           |        |        |        |       |   | Edited By                                       |  | Approved By                              |  | EC Number       | Release Date |
| White Paper                        |        |        |        |       |   | P. Bockelman                                    |  | M. Sasso                                 |  | 48533           | 03-28-14     |
| Notes                              |        |        |        |       |   | Title   |  |  |  |                 |              |
| 1. Printed two sides.              |        |        |        |       |   | User Guide, CO-Series, CO-100                   |  |  |  |                 |              |
| 2. Printed black.                  |        |        |        |       |   | Creation Date                                   |  | Number                                   |  | Revision        |              |
| 3. See sheet 2 for artwork.        |        |        |        |       |   | 04-14-2011                                      |  | P516-270                                 |  | E               |              |
| 4. Tolerance +/- .13.              |        |        |        |       |   | Created By                                      |  | Activity                                 |  | © Allegion 2014 |              |
| 5. Printed in country may vary.    |        |        |        |       |   | P. Bockelman                                    |  | 3899 Hancock Expwy<br>Security, CO 80911 |  |                 |              |
| 6. Center-stitched booklet format. |        |        |        |       |   | Software: InDesign CS6                          |  |  |  |                 |              |