

Detex Corporation, 302 Detex Drive, New Braunfels, Texas 78130-3045
(830)629-2900 / 1-800-729-3839 / Fax (830)620-6711
E-MAIL: detex@detex.com INTERNET: www.detex.com

INSTRUCTIONS FOR DETEX® EWH8-626 ELECTRIFIED HINGE

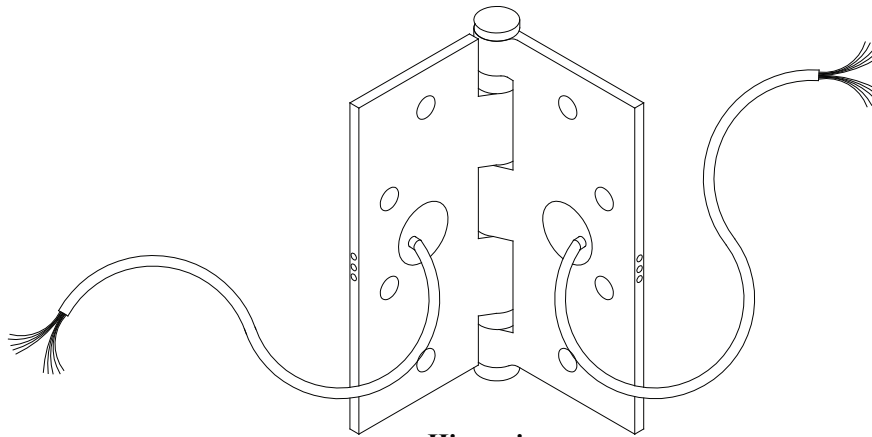

Hinge size:
4-1/2" x 4-1/2" x 5 knuckle, 8 wire

| | |
|-------|--------|
| 20AWG | Red |
| 20AWG | Black |
| 22AWG | Blue |
| 22AWG | Orange |
| 28AWG | Brown |
| 28AWG | Yellow |
| 28AWG | White |
| 28AWG | Gray |

TOOLS REQUIRED:

- Drill Motor
- 3/8" drill bit
- 3/4" drill bit
- Center punch
- Hammer
- Safety Glasses

DOOR PREPARATION:

The wire chase should be drilled through the door with a 3/8" drill bit starting at point noted on the hinge template.

The Detex hinge should always be positioned as one of the center hinges on the door, since the modified hinge no longer meets manufacturers load bearing specifications.

A starter hole of 3/4" dia x 1-1/2" deep is recommended for positioning the splice of the hinge wire and lock through wire.

Be careful not to pinch wires between the door and hinge when securing the hinge to the door. This may cause the hinge to malfunction.

Note: In fire rated conditions be sure to confirm the maximum starter hole diameter and depth with the appropriate testing agency.

FRAME PREPARATION:

Mark and drill hole to receive the wires from the Detex hinge.

Be careful not to pinch wires between the door and hinge when securing the hinge to the door. This may cause the hinge to malfunction.

Note: Steel based hinges are for interior use only. Use stainless steel or brass based hinges for exterior installations.

Do not allow hinge to dangle from its wires during installation

BURGLAR ALARM SYSTEMS APPLICATIONS:

The ETH hinges are used to pass low voltage power from a frame hinge jamb to the door to power lock sets, exit devices and door monitoring devices such as door position switches, request to exit switches, etc.

Detex does not recommend splicing hinges containing 28AWG wire to any wire heavier than 20AWG.

