

CHANGING LEVER HANDING

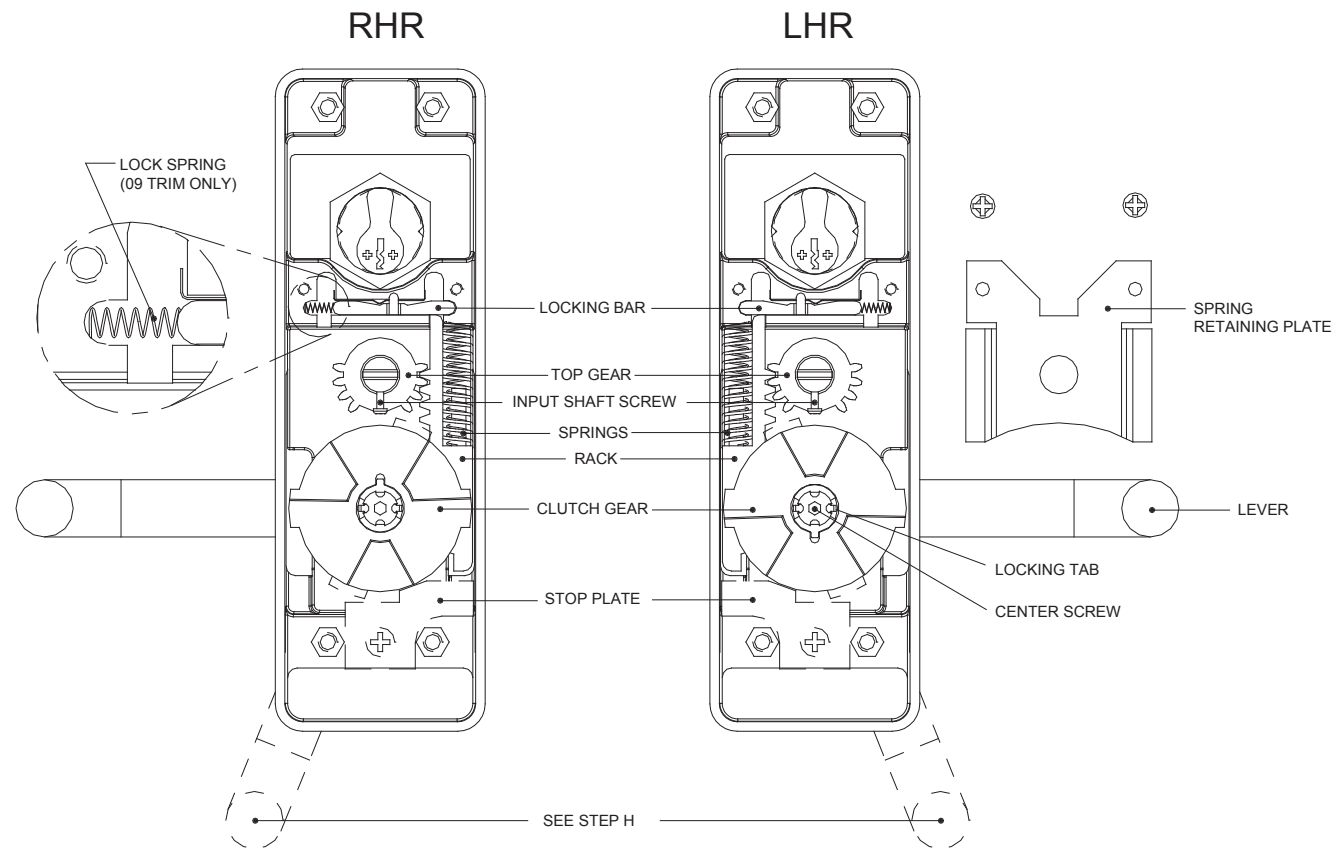

103129 September 14, 2009



- A. Remove input shaft screw. (Remove input shaft if necessary).
- B. Remove stop plate.
- C. **WARNING: Springs under pressure!** Remove spring retaining plate. Carefully remove the springs.
- D. **(For 09 Function only)** Switch lock spring to opposite side.
- E. Remove top gear.
- F. Loosen the clutch center screw approximately two (2) turns. Bend locking tab back to disengage with notch.
- G. Slide the locking bar away from the rack (not necessary for 14 function). Remove the rack while rotating the lever.
- H. Continue rotating the lever to the opposite side.
- I. Rotate the lever to the position shown. Partially engage the rack and the clutch gear on the opposite side.
- J. Rotate the lever until the rack is completely seated.
- K. Insert the top gear.
- L. Add permanent thread locking adhesive and tighten the clutch center screw. Bend tab over screw notch so that screw cannot turn.
- M. **WARNING: Springs under pressure!** Install the springs. Hold the lever in the open position, firmly compressing the springs in place.
- N. While holding the lever in the open position, replace the spring retaining plate and fasten the two (2) screws.
- O. Reverse the stop plate and fasten the screw.
- P. Replace input shaft screw. Handing complete.

Detex Corporation, 302 Detex Drive, New Braunfels, Texas 78130-3045
 (830)629-2900 / 1-800-729-3839 / Fax (830)620-6711
 E-MAIL: detex@detex.com INTERNET: www.detex.com

INSTALLATION INSTRUCTIONS FOR MORTISE OUTSIDE LEVER TRIMS

08DM, 08DMT, 08DMU
09DM, 09DMT, 09DMU
14DM, 14DMT, 14DMU

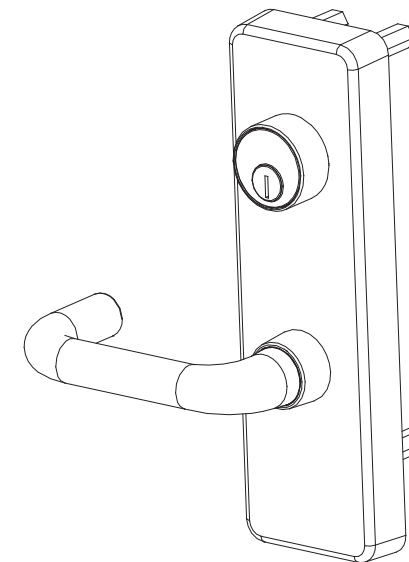

08 or 09 LEVER TRIM

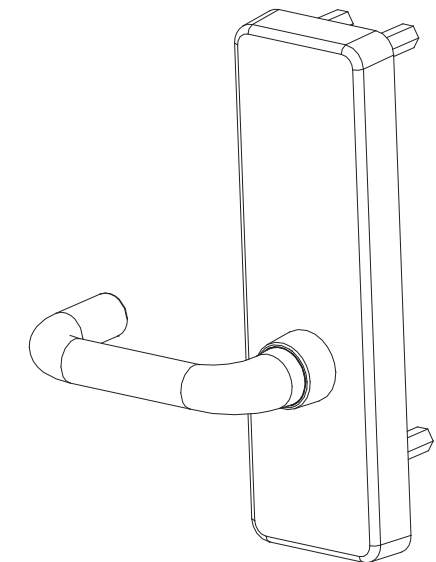

14 LEVER TRIM

08, 09, 14 LEVER TRIM INSTALLATION INSTRUCTIONS

NOTES:

- 1) Mortise lock NOT supplied with TRIM device.
- 2) For a retrofit application, remove lock and device before installing new trim.
- 3) LHR installation shown (Reverse all steps for RHR).

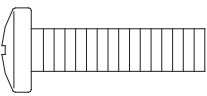
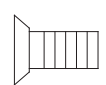
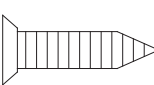
Machine Screws		Sheet Metal / Wood Screw	Lock washer
A	I	J	#1/4 Lock washer
#1/4-20 x 1"	#12-24 x 1/2"	#12 x 1"	
			

STEP 1: PREP DOOR

1 TRIM side: Use plastic template to mark and drill TRIM holes

MARK HOLES

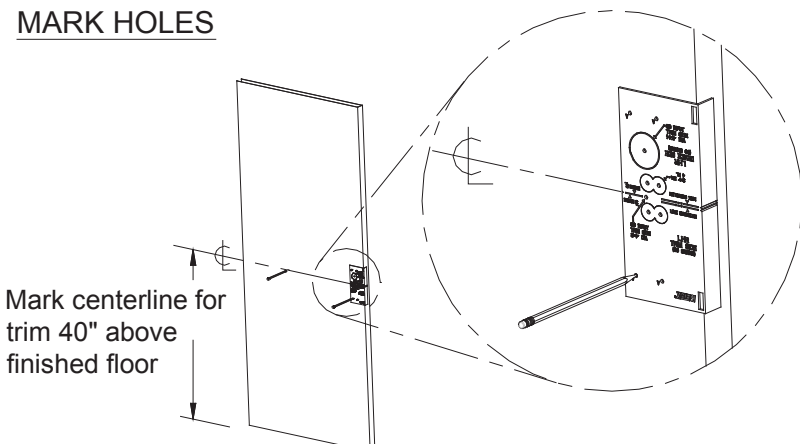

Mark centerline for trim 40" above finished floor

DRILL HOLES

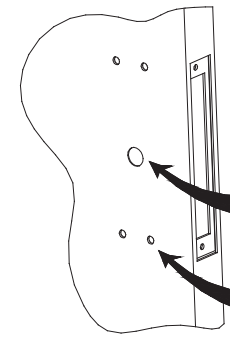

Drill 3/4" diameter hole thru trim side only

Drill 1/2" diameter holes thru trim side only 4 places

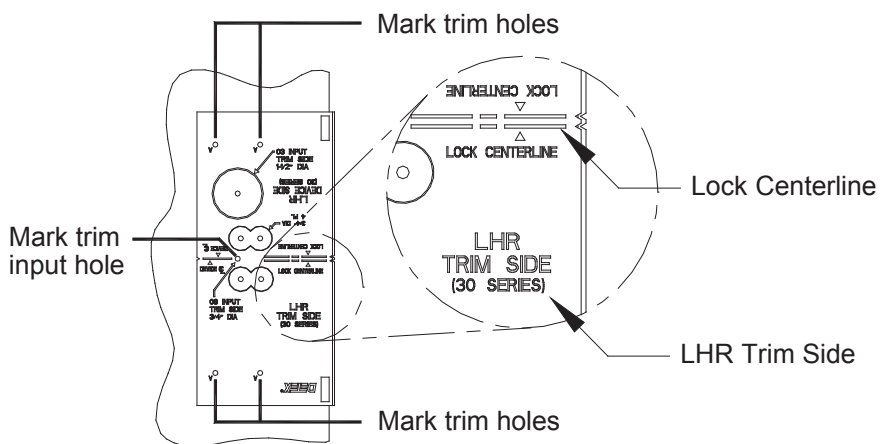

Mark trim holes

Lock Centerline

LHR Trim Side (30 SERIES)

Mark trim input hole

STEP 2: PREP TRIM DEVICE

2 Install mortise cylinder and trim input shaft

NOTE:

1. Key should turn cylinder easily to slide locking bar in both directions.
2. Mortise cylinder installed on 08 & 09 trims only
3. Mortise cylinder NOT supplied with trim, but can be ordered separately

Cylinder P/N: 102281-X

Short collar included P/N: 100572-X

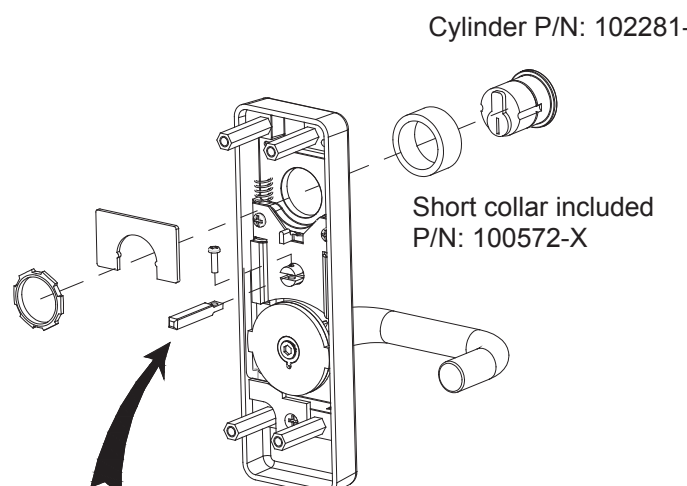

Install trim input shaft

STEPS 3-4: INSTALL MORTISE LOCK AND TRIM DEVICE

3 Install MORTISE lock

Install lock with (2) "I" screws or (2) "J" screws for wood doors.

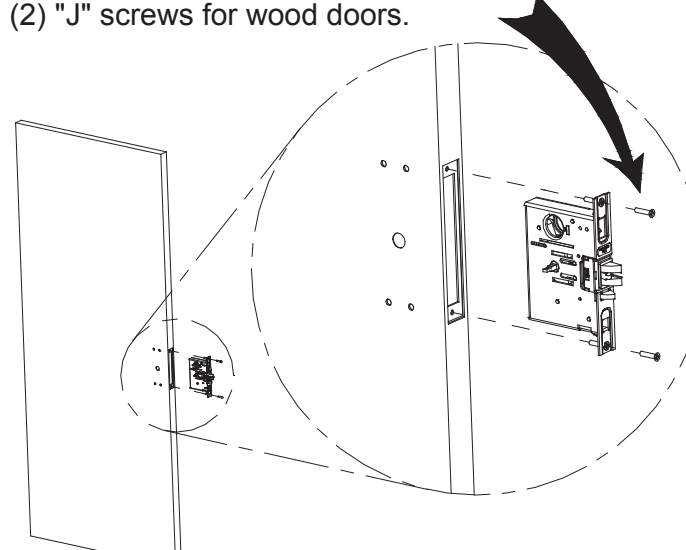

IMPORTANT!

For modular cable devices, see electrical instructions for cable routing

4 Install TRIM device

#1/4 Lockwasher

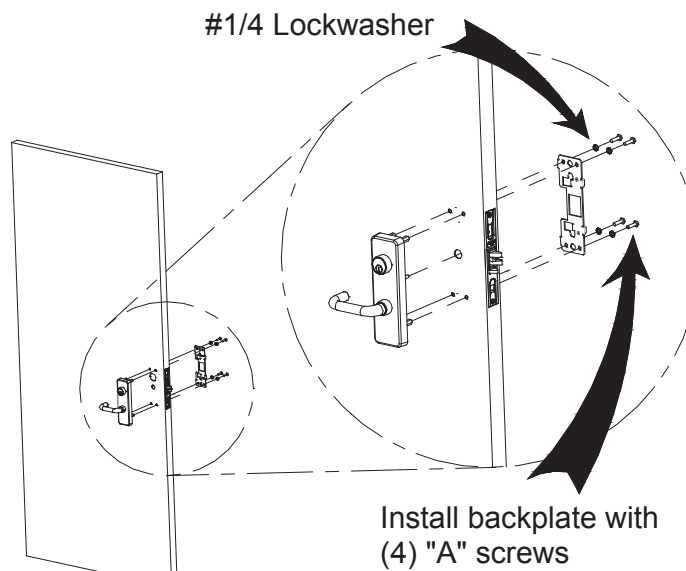

Install backplate with (4) "A" screws

TRIM INSTALLATION COMPLETE

Continue installation using device instructions (p/n:101349)