

Detex Corporation, 302 Detex Drive, New Braunfels, Texas 78130-3045 (830)629-2900 /1-800-729-3839 /FAX(830)620-6711  
E-Mail: detex@detex.com Internet: www.detex.com

## INSTALLATION INSTRUCTIONS FOR ADVANTEX TRIM

OUTSIDE LEVER TRIM 08/09/14  
(08 Trim - includes 08D, 08DT, 08DU)  
(09 Trim - includes 09D, 09DT, 09DU)  
(14 Trim - includes 14D, 14DT, 14DU)

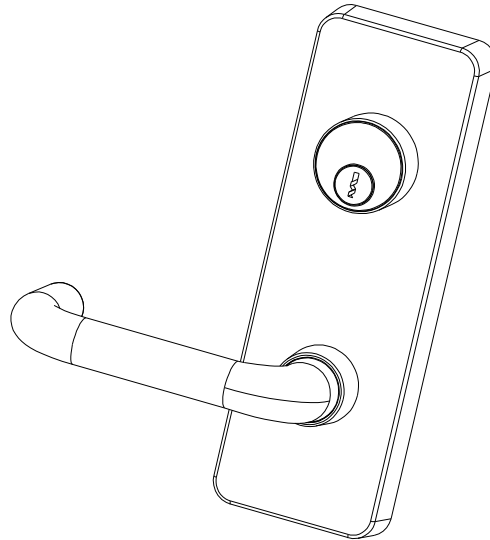

### TOOLS AND SUPPLIES

Safety Glasses  
**(Always put on safety glasses prior to beginning installation of unit)**  
Pencil  
1/8" Hex Wrench  
Center Punch  
Hammer  
Drill Motor  
Drill Bits & Taps  
Screw Driver (Flat Head & Phillips Drive)  
Tape Measure

## PREPARING THE TRIM

1. The lever trim is handed. Refer to "CHANGE LEVER HANDING" on pages 4 and 5 if needed.

### INSTALLING THE MORTISE CYLINDER -08 and 09 FUNCTIONS ONLY - Instruction 2 and 3:

2. A short cylinder collar is supplied for mortise cylinders 1" to 1-1/8" long. For cylinders greater than 1-1/8", order tall cylinder collar part #100752-X.

3. Insert the mortise cylinder (not included). (See Fig. T8). Fasten the cylinder with the large hex nut. **Note: The key should turn the cylinder easily to slide the locking bar in both directions.** **Caution: The back of the cylinder should not protrude beyond the depth of the trim escutcheon.**

Fig. T8

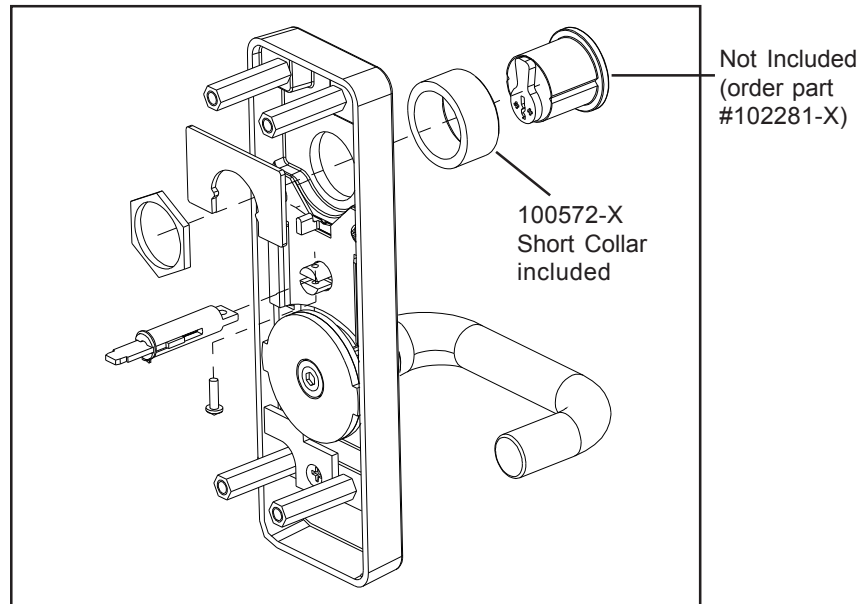

### PREPARING THE TRIM - CONTINUED - FOR 08 FUNCTION, 09 FUNCTION AND 14 FUNCTION:

4. Attach the tail piece extension to the top gear with screw provided.

### PREPARING THE DOOR:

5. Center punch holes "a" and "d" marked earlier.

6. Drill two (2) pilot holes "a" (holes located diagonal from each other for standard stile). **Caution: Be sure to drill STRAIGHT through the door .**

7. Drill pilot holes for remaining holes "a" through inside of door only.

8. Drill pilot hole "d". **Caution: Be sure to drill STRAIGHT through the door .**

9. Using Back Plate as template on outside, align the two (2) pilot holes "a". Mark, center punch and drill pilot holes for the two (2) remaining holes "a".

10. At the outside and inside trim cam hole "d", drill a 3/4" hole.

| HOLES "a"   | HOLES "d"   |
|---|---|
| INSIDE<br> 5/16" |  3/4" |
| OUTSIDE<br> 1/2" |   |

Fig. T9

11. Drill holes "a" according to the chart (Fig. T9).

#### ASSEMBLING THE OUTSIDE TRIM AND BACKPLATE

12. Align the hex stand-offs and trim assembly through the drilled holes (Fig. T10).

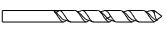
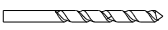
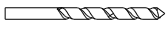
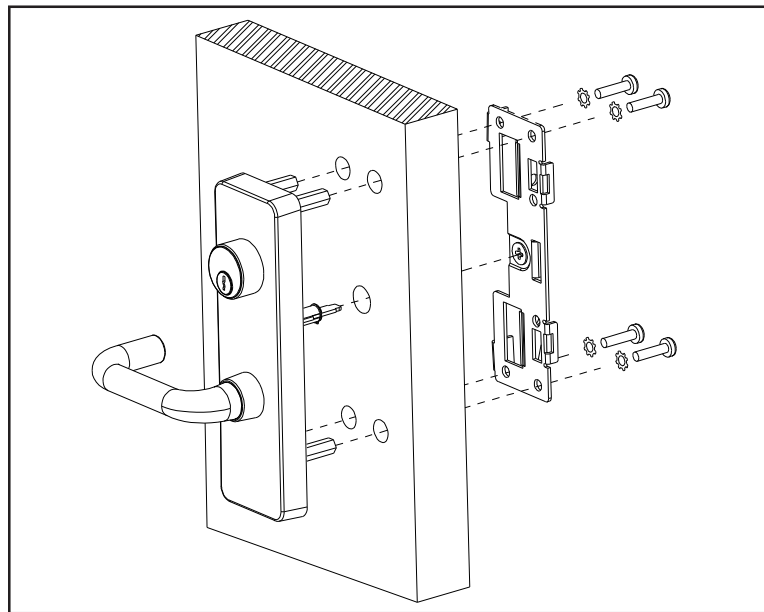

Fig. T10

13. Align the tail piece extension into the backplate's trim cam on the inside face of the door.

14. Fasten the backplate to the inside face of the door with lockwashers and 1/4-20 machine screws provided with Exit Device Hardware Kit. **Caution: The lever should easily operate the inside trim cam.**

15. Resume the panic hardware instruction #15.

CHANGE LEVER HANDING  
(Refer to Fig. T11 on page 5)

- A. Remove tailpiece extension assembly screw. (Remove tailpiece extension assembly if necessary).
- B. Remove stop plate.
- C. **Warning: Springs under pressure!** Remove spring retaining plate. Carefully remove the springs.
- D. Switch lock spring to opposite side (for 09 Function only).
- E. Remove top gear.
- F. Loosen the clutch center screw approximately two (2) turns. Bend locking tab back to disengage with notch.
- G. Slide the locking bar away from the rack (not necessary for 14 function). Remove the rack while rotating the lever.
- H. Continue rotating the lever to the opposite side.
- I. Rotate the lever to the position shown. Partially engage the rack and the clutch gear on the opposite side.
- J. Rotate the lever until the rack is completely seated.
- K. Insert the top gear.
- L. Add permanent thread locking adhesive and tighten the clutch center screw. Bend tab over screw notch so that screw cannot turn.
- M. **Warning: Springs under pressure!** Install the springs. Hold the lever in the open position, firmly compressing the springs in place.
- N. While holding the lever in the open position, replace the spring retaining plate and fasten the two (2) screws.
- O. Reverse the stop plate and fasten the screw.
- P. Replace tailpiece extension assembly screw. Handing complete.

RHR

LHR

LOCK SPRING  
(09 TRIM ONLY)

LOCKING BAR

TOP GEAR

TAILPIECE EXT.  
ASSEMBLY SCREW  
SPRINGS

RACK

CLUTCH GEAR

STOP PLATE

LOCKING TAB

CENTER SCREW

SEE STEP H

View from back side  
(With Spring Retaining Plate Removed)

Fig. T11