



Detex Corporation, 302 Detex Drive, New Braunfels, Texas 78130-3045  
830-629-2900 / 800-729-3839 / Fax 800-653-3839 / Text photos only: 830-481-6433 / INTERNET: www.detex.com

INSTALLATION INSTRUCTIONS FOR 02Z & 03Z ANTI-VANDAL TRIM

02Z ANTI-VANDAL TRIM P/N: 105640  
03Z ANTI-VANDAL TRIM P/N: 105650

Table of Contents	Page
Device parts breakdown view & part numbers.....	2
Trim Prep, Door Prep - Interior Door Face.....	3
Door Prep - Exterior Door Face, Install Trim.....	4

Should you have a Question/Problem with your Detex device please call Detex Technical Support from job site at 1-800-729-3839 and choose option 2 on our menu. Please do not return the product to the distributor.

For WARRANTY information,  
scan code below or  
go to [www.detex.com/warranty](http://www.detex.com/warranty)

For device installation videos,  
scan code below or  
go to [www.detex.com/videos](http://www.detex.com/videos)



Owner's Copy



PARTS BREAKDOWN			
Item	P/N	QTY	Description
1	105641-630	1	TRIM, 02Z, ANTI-VANDAL
	105649-LHR-630		TRIM, 03Z, ANTI-VANDAL, LHR
	105649-RHR-630		TRIM, 03Z, ANTI-VANDAL, RHR
2KIT	105646-2	1	KIT, 03Z TRIM
2A	PP-5066-12	2	LOCKWASHER, #12
2B	100980	4	SCREW, 1/4-20 x 1
2C	101454-1	1	TAILPIECE ASSEMBLY, RIM, 03WS
2D	101480-1	1	TAILPIECE, 03 WSN (for 2-1/4" thick door)
3	100752-9	1	CYLINDER COLLAR, TALL
4	ECL-445-7-X	1	CYLINDER, 5 PIN RIM (sold separately)
	IC7R-626		CYLINDER, 7 PIN RIM (sold separately)

FOR ITEM 4  
"-X" REFERS TO  
KEY CODE  
AA-KK

Your particular part or configuration may not be shown:  
Contact Detex technical support at 800-729-3839 (option 2)

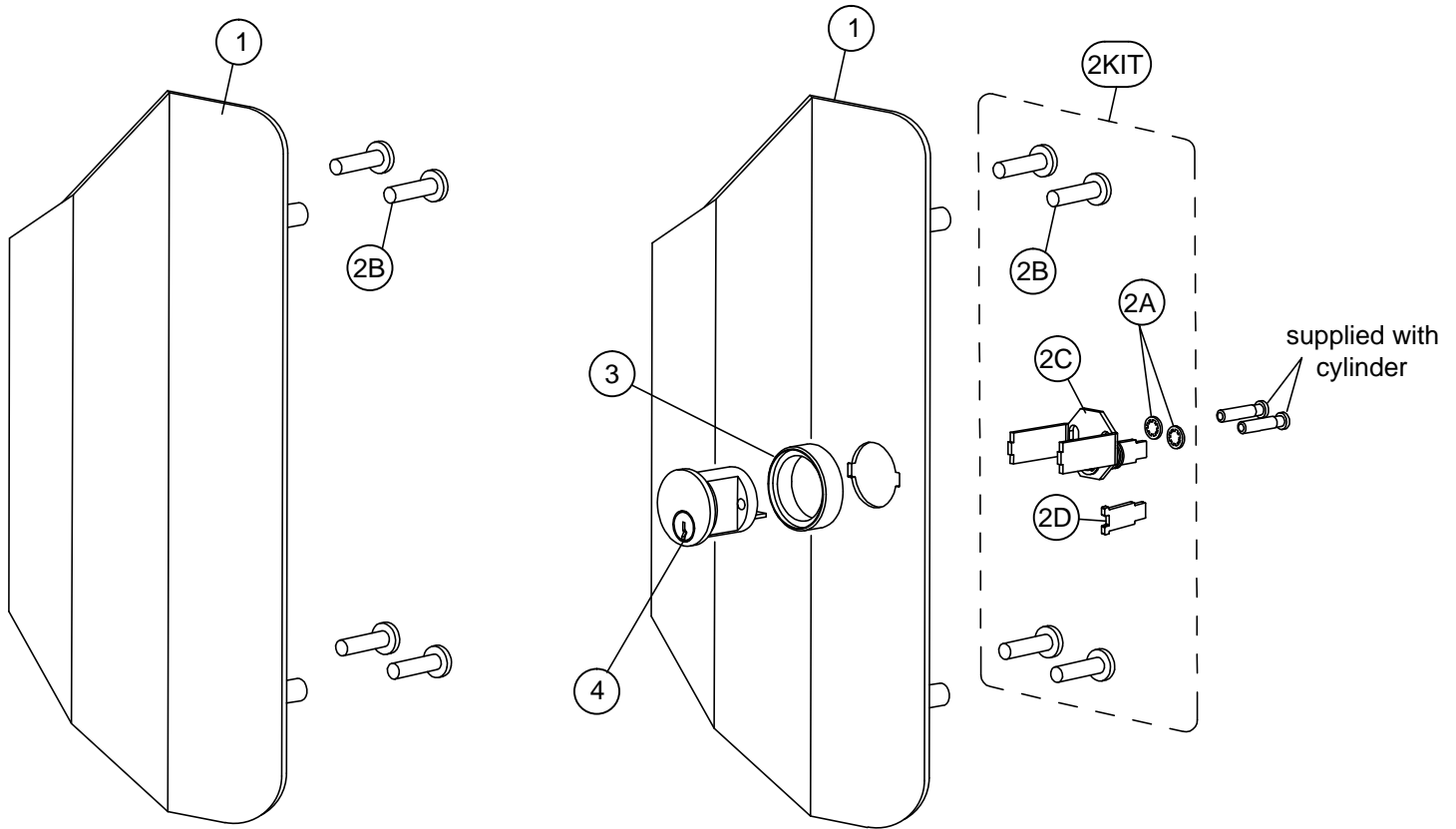

02Z

03Z



- Tools Required:  
 Safety glasses  
 Tape measure  
 Pencil  
 Hammer  
 Center punch  
 Drill  
 3/8" drill bit  
 1-1/2" Hole saw (for 03Z)  
 3/4" drill bit (for 03Z)  
 Screwdriver

# 03Z Trim Prep

(No prep necessary for 02Z trims)

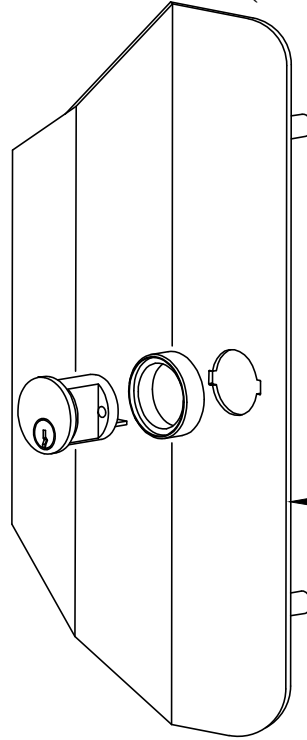
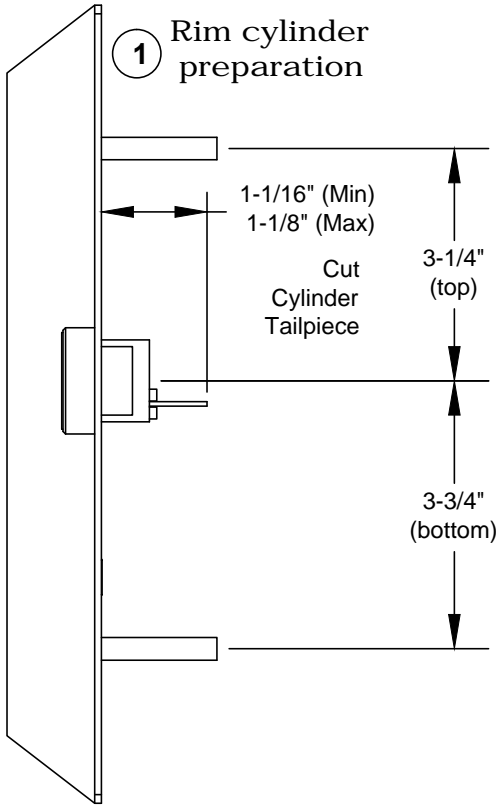
## 2 Install cylinder and tailpiece assembly (LHR shown, RHR opposite)



Tailpiece Used	Door Thickness
	1-3/4" and 2" Thick Doors (installed)
	2-1/4" Thick Doors (in hardware kit)

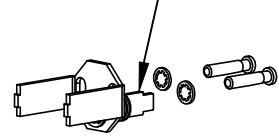

Replace the installed tailpiece with the longer one in the hardware kit if being installed on 2-1/4" thick door

THIS EDGE TOWARDS LATCH SIDE OF DOOR

## Door Prep - Interior Door Face (LHR shown)

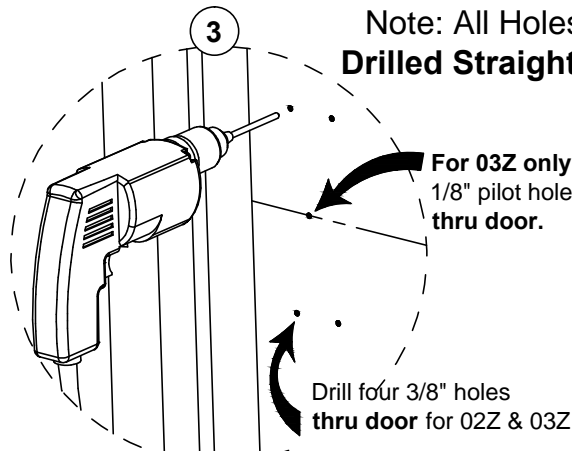
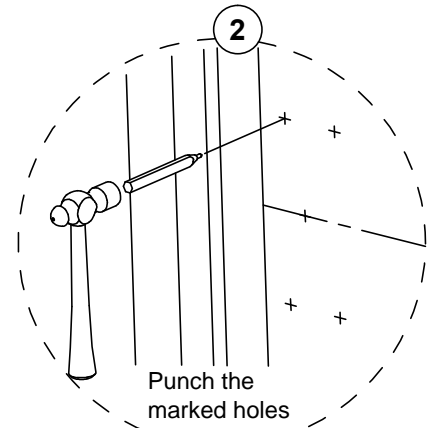
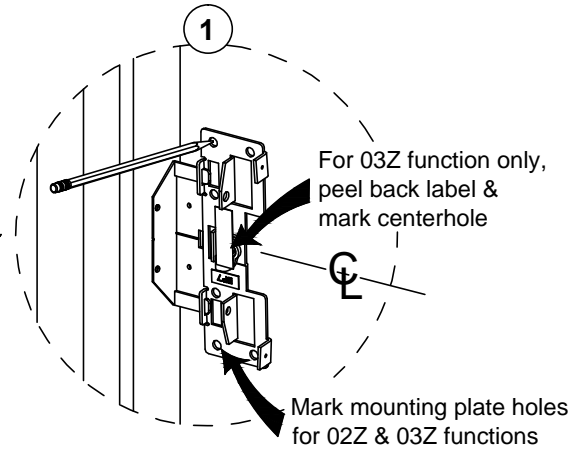
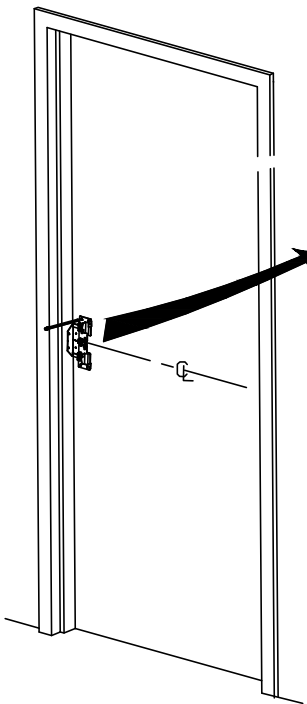

**Note: All Holes Must Be Drilled Straight and Level**

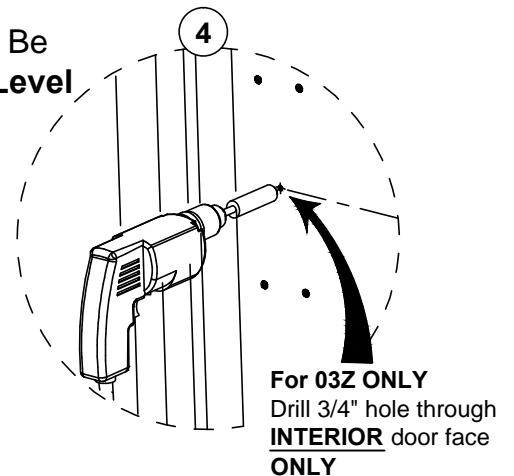

# Door Prep - Exterior Door Face - 03Z only (LHR shown)

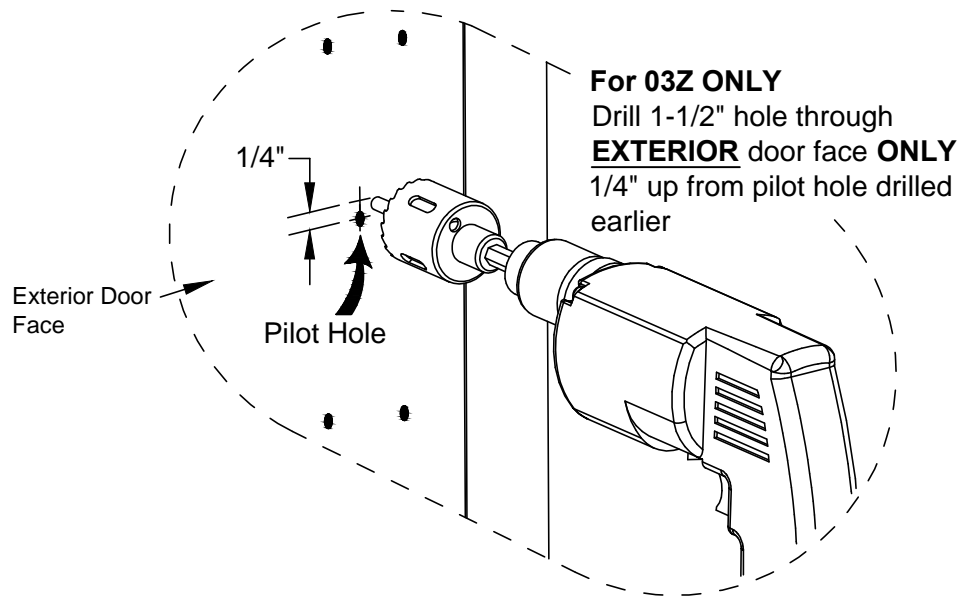

## Install Trim (03Z shown)

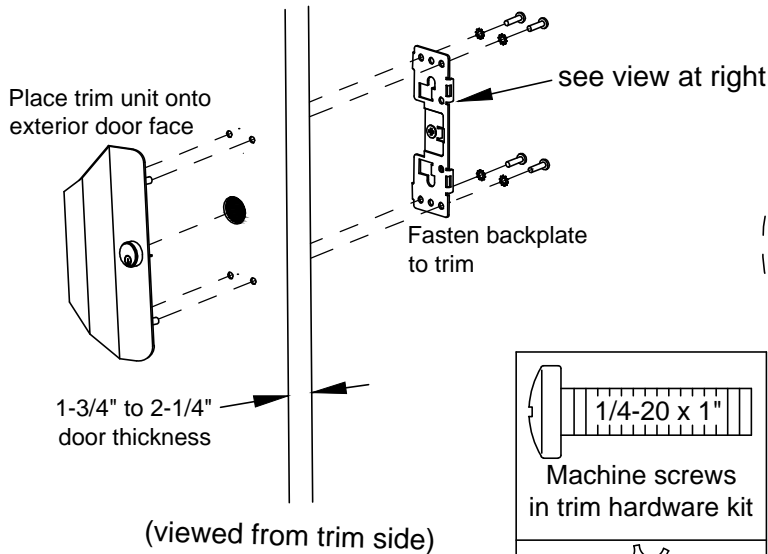

Be sure to engage trim  
tailpiece to cam on mounting  
plate (with key out of cylinder)

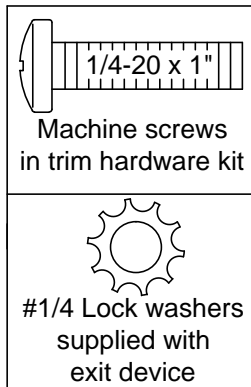
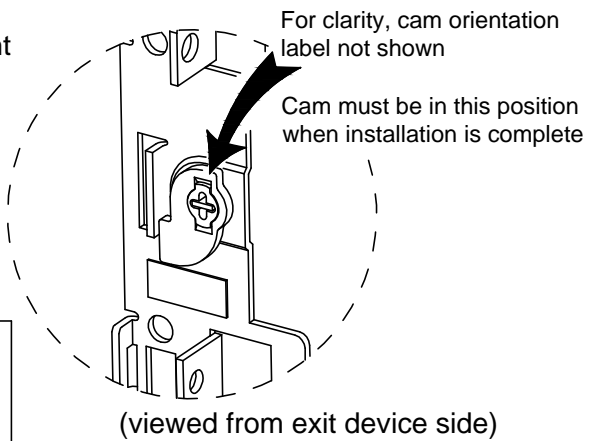

Continue with Exit  
Hardware Instructions