

INSTALLATION INSTRUCTIONS

RIM EXIT DEVICE SERIES 2400 & FL2400 - NON-HANDED

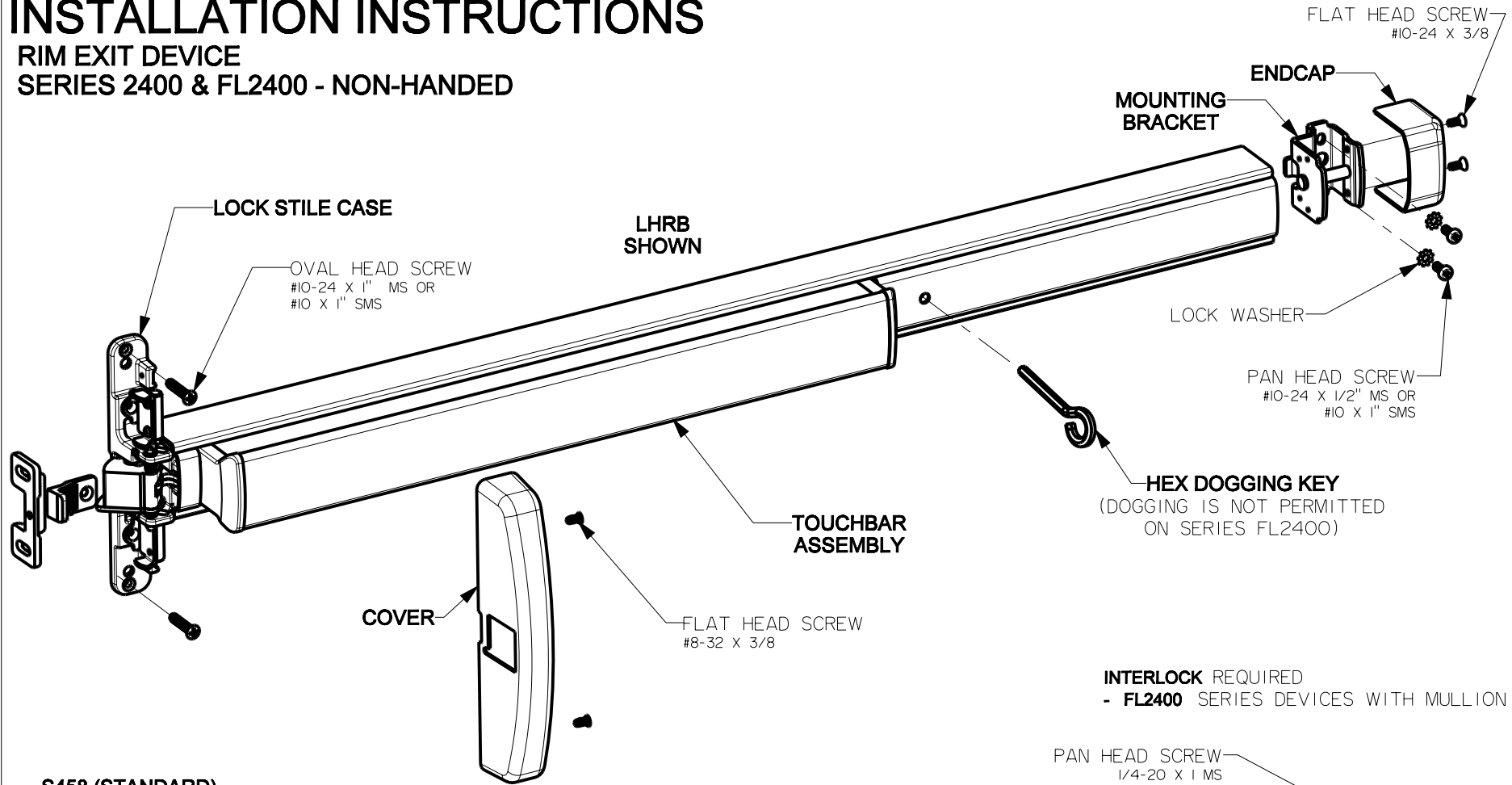

INTERLOCK REQUIRED
- FL2400 SERIES DEVICES WITH MULLION

**S458 (STANDARD)
HOLLOW METAL FRAME
AND MULLION**

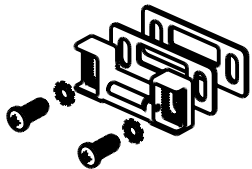

**S988 (STANDARD)
ALUMINUM FRAME**

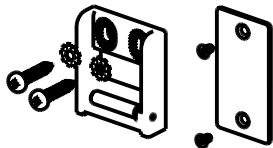

S301 (OPTIONAL)

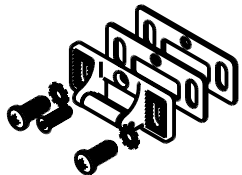

S300 (OPTIONAL)

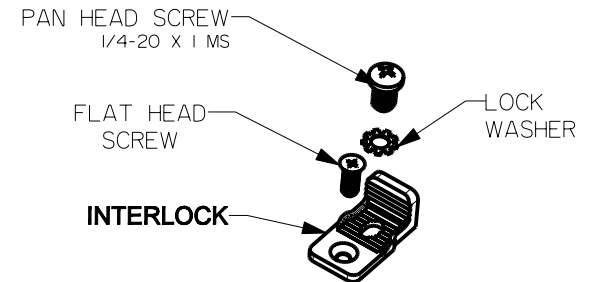
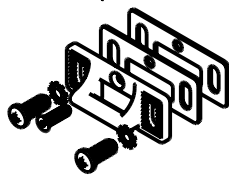

STRIKES AND SCREWS	S300 OR S301	S458	S988
1/4-20 X 3/4 MS	2	2	0
#14 X 1" SMS	2	2	0
#10-24 X 3/4" MS	1	0	0
#10 X 1" SMS	1	0	2
#10-24 X 1/2" MS	0	0	2
LOCK WASHER	2	2	2
#6-32 X 1/4" MS	0	0	2
RUB STRIP	0	0	1

FIRE EXIT DEVICES SERIES FL2400

Sex bolts or through bolts are required for composite (Wood, Plastic and Steel covered), wood core, sheet metal and hollow metal doors without reinforcement unless door manufacturer has an alternate mounting method. Fire doors with steel reinforcement, mount devices with machine screws

DEVICE PREPARATION

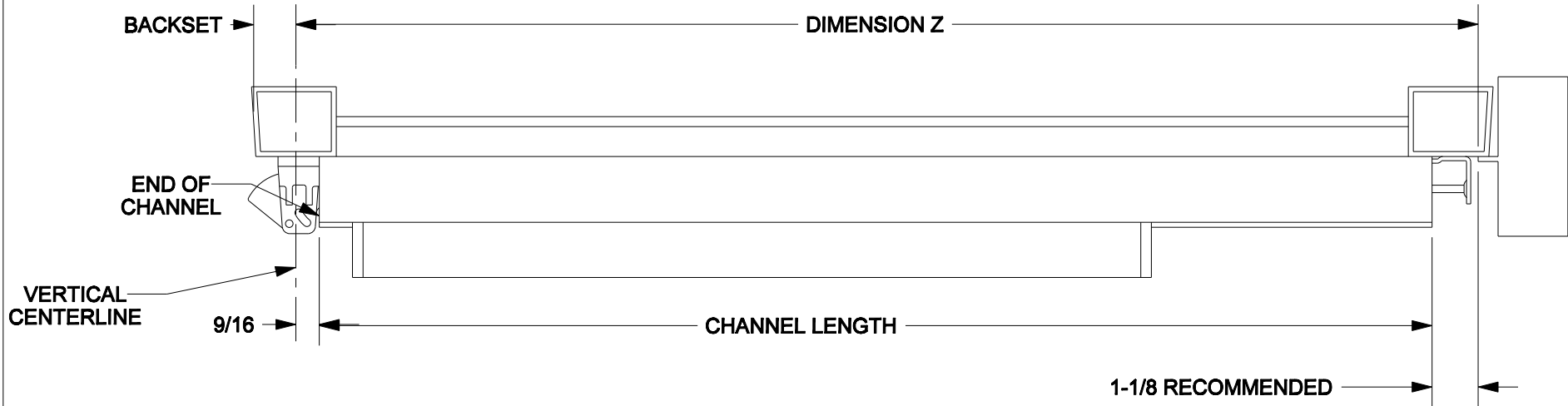

CUT DEVICE: - If Required

1. Determine proper **CHANNEL LENGTH** by subtracting 1-11/16" from dimension **Z**.
2. Mark cut off point (hinge side filler must be all the way inside of channel).
3. Cut off channel and hinge side filler and deburr.



WARNING:

If your device is equipped with ALK, CD, DE, or DS then please refer to instruction sheet listed below prior to cutting the device.

ALK	Alarm Kit	01639-11-000
CD	Cylinder Dogging	01725-11-000
DE	Delayed Egress	01844-11-000
DS	Door Position	02187-11-000

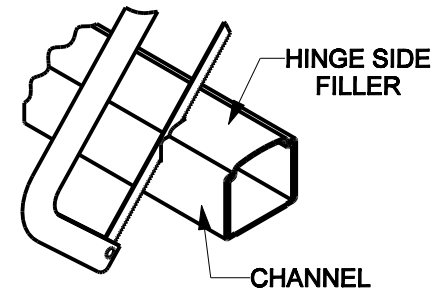

- CAUTION -
PROTECT INSIDE OF DEVICE
FROM METAL SHAVINGS

1 DOOR PREPARATION

- Circle the following **STRIKE NO**, **Dimension "X"**, and **BACKSET** in the chart below. **TRIM NO** (if specified) at various locations (holes B, BI, and C) on the trim template.
- Close door. Mark **HORIZONTAL CENTERLINE** on inside face of door and **DOOR STOP** or **ALUMINUM FRAME** 39-15/16" from finish floor, or as required for the specific installation. (Continue horizontal centerline to outside face of door if trim is specified)
- Mark **VERTICAL CENTERLINE** at lock side using dimension **"X"**. (If trim is specified mark vertical centerline on the outside face of door using backset dimension)
CAUTION: Vertical centerlines on both sides of the door should be the same dimension from the edge of the door.

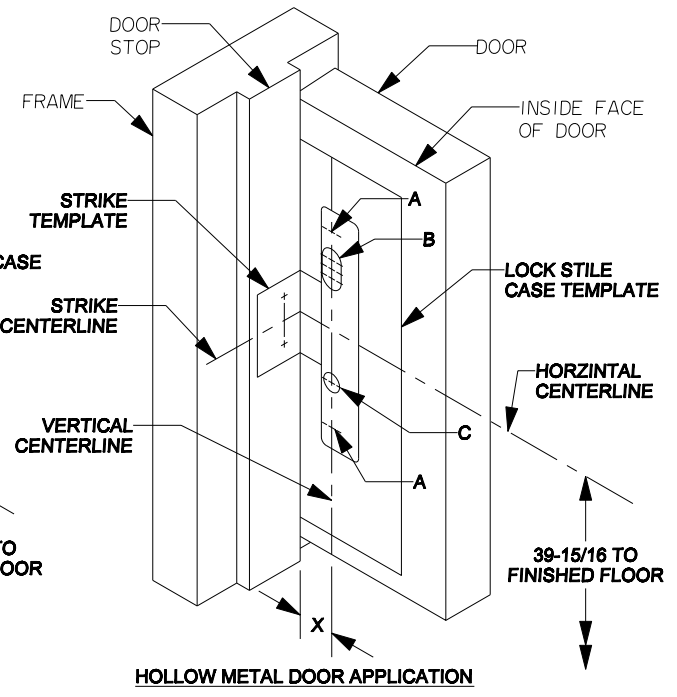
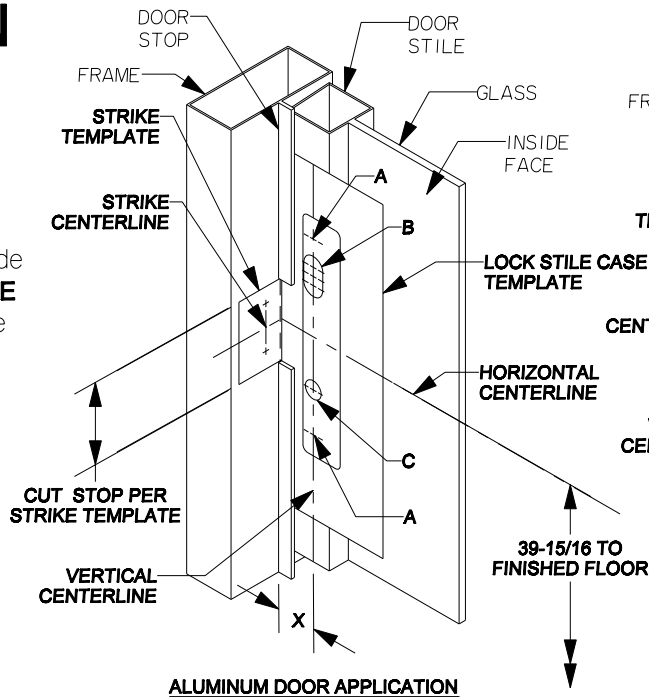

- Tape Lock Stile Case Template (and Trim Template if Trim specified) to the door so that the centerlines on the Template line up with centerlines on the door. Mark centers and drill the required holes as indicated on the templates.
- 5A. Strike machining for Aluminum Frame see S988 Strike Instructions packed with strike.
- 5B. Fold Strike Template and place on door stop or mullion and inside face of door, so the horizontal centerline on template lines up with the horizontal centerline on door stop and door. Tape template on the door stop or mullion and the door face. Mark centers and drill holes as indicated on the template.

	SINGLE DOOR			PAIR OF DOORS WITH MULLION	
	ALUMINUM	HOLLOW METAL			
STRIKE No.	S988	S458	S300 S30I	S458	S300 S30I
DIMENSION X	1-3/16	1-3/16	1-7/16	1-3/16	1-7/16
BACKSET	1-1/16	1-11/16	1-15/16	2-1/16	2-5/16
STILE WIDTH	1-3/4 MIN	2-5/8 MIN	2-7/8 MIN	3 MIN	3-1/4 MIN

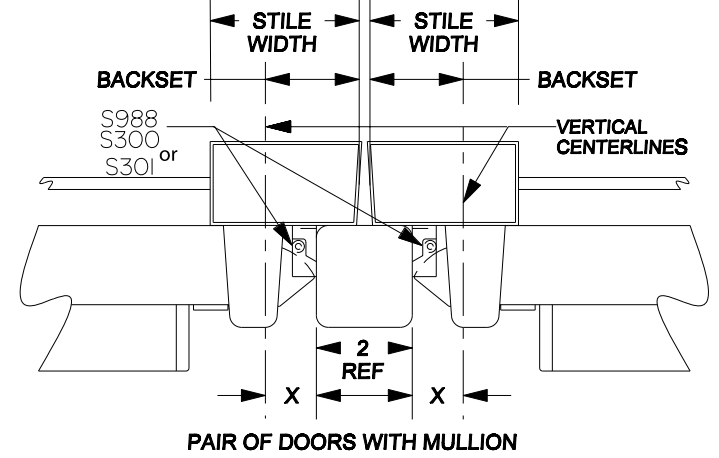
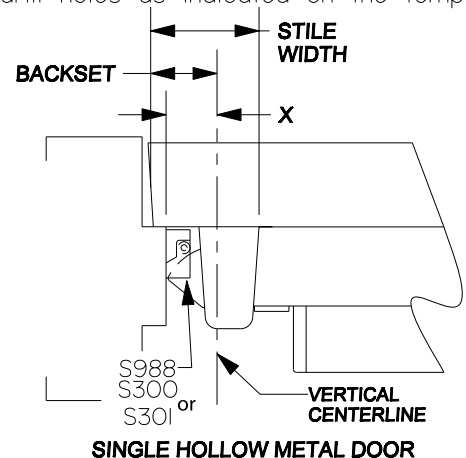
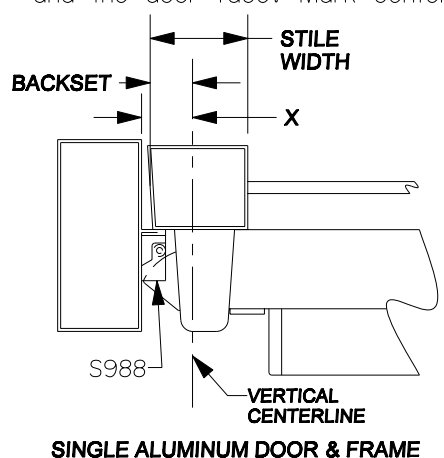

2 APPLY DEVICE

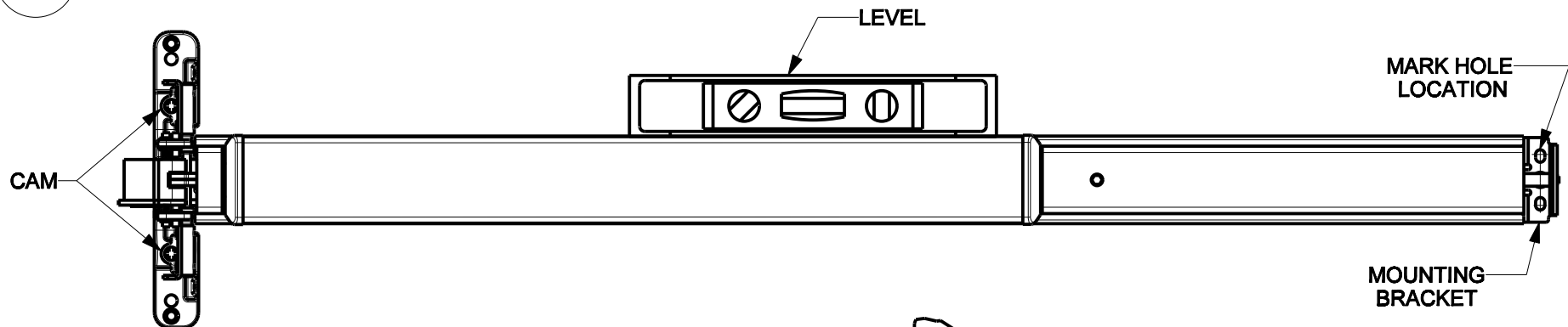

NOTE: If Trim is specified: See the Trim installation instructions packaged with the trim. If the Exit Device has Electrical or other options see specific option instructions packaged in exit device carton.

1. Lock Stile case Mounting

DEVICE WITH TRIM - See Trim instructions

CYLINDER ONLY - Install cylinder with cylinder back plate as shown. Make sure the tailpiece is extending 1/4" to 5/16" from the inside face of door.

Insert tailpiece into **CAM** in the lock stile chassis and mount it to the door with 2 screws.

EXIT ONLY - Mount Lock Stile case to the door with 2 screws.

2. Insert **MOUNTING BRACKET** into touch bar assembly tight against channel. Level device, mark and drill 2 holes for #10 sheet metal screws or #10-24 machine screws. Fasten **MOUNTING BRACKET** to door and attach **ENDCAP** with 2 screws.

3. Fasten strike to frame and adjust strike so that the device latches tightly without binding. Strike shims are provided if excessive gap is apparent between latch and strike lip.

- For S300 and S301 strikes apply third center screw once adjustment is complete.
- For S988 strike apply rub strip to the aluminum frame as shown on instructions packaged with strike.
- For FL with mullion devices, install interlock by sliding it into slot under Lock Stile Case. Secure with screws and lock washer.

4. Attach cover to lock stile case.

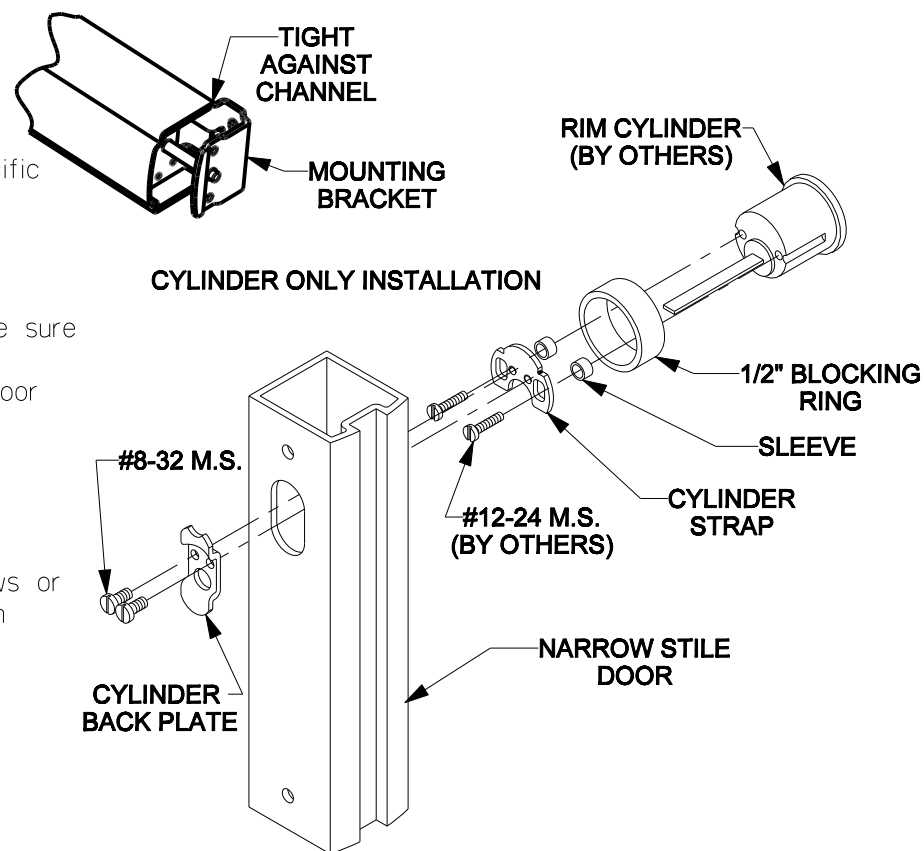

STANLEY

phi

DRWG 01813-11-000 DATE 09/2014 REVISION D

Precision Hardware
a Division of Stanley Security Solutions, Inc.
www.stanleysecuritysolutions.com