

INSTALLATION INSTRUCTIONS

CONCEALED VERTICAL ROD EXIT DEVICE - REVERSIBLE
 SERIES 2800 , FL2800, 2800LBR & FL2800LBR

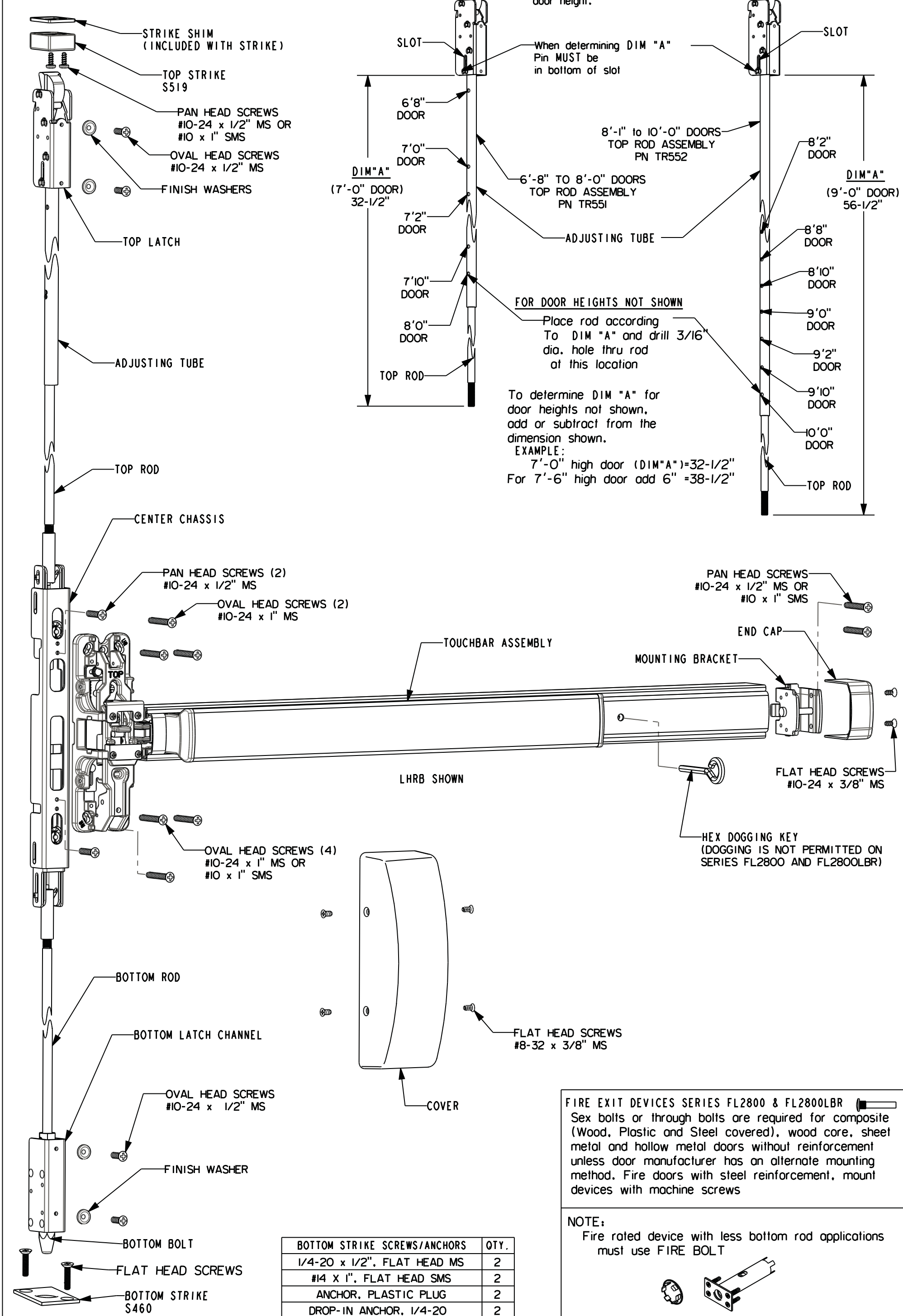

INSTRUCTIONS TO CHANGE HAND

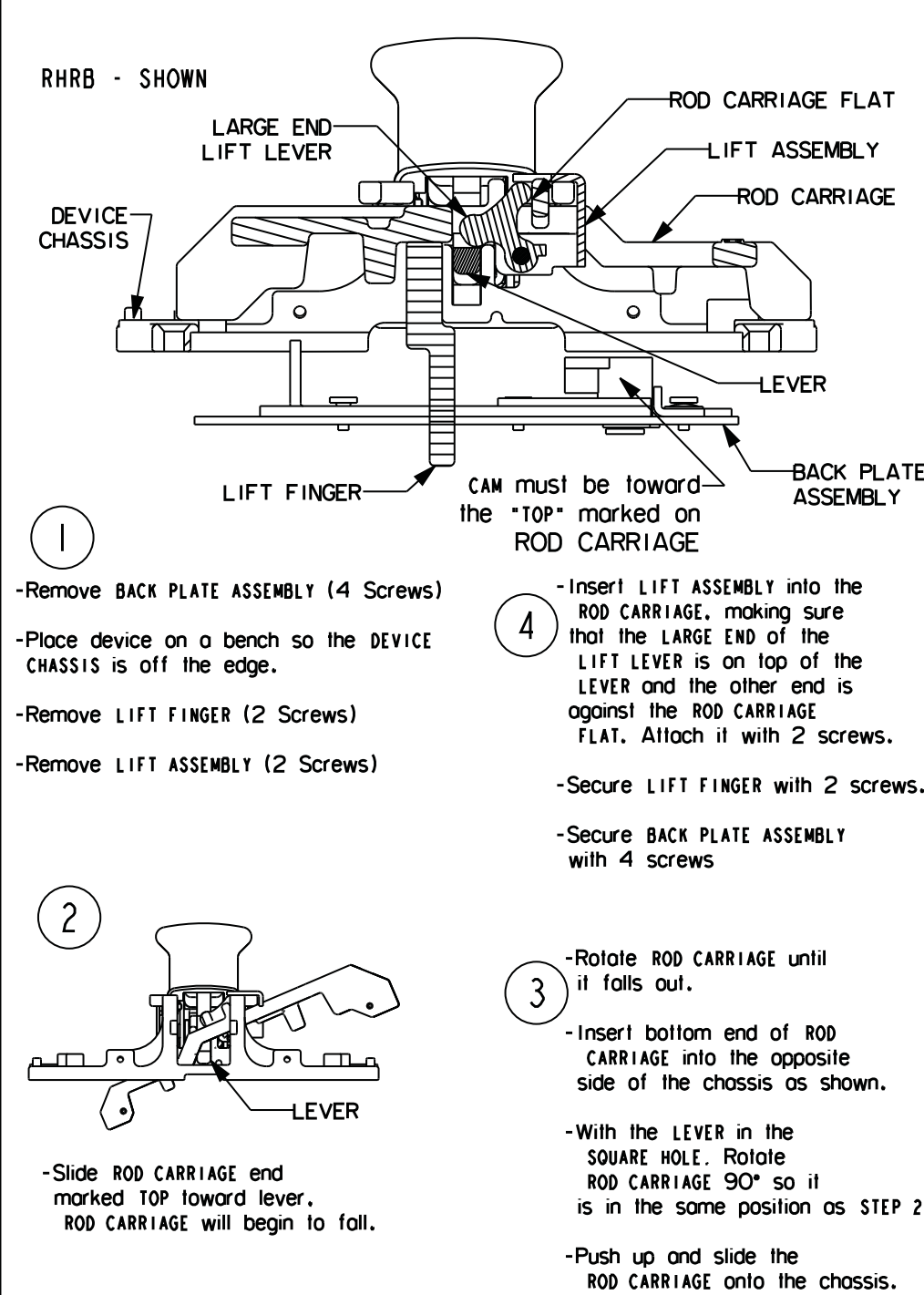

INSTRUCTIONS TO CHANGE FUNCTION

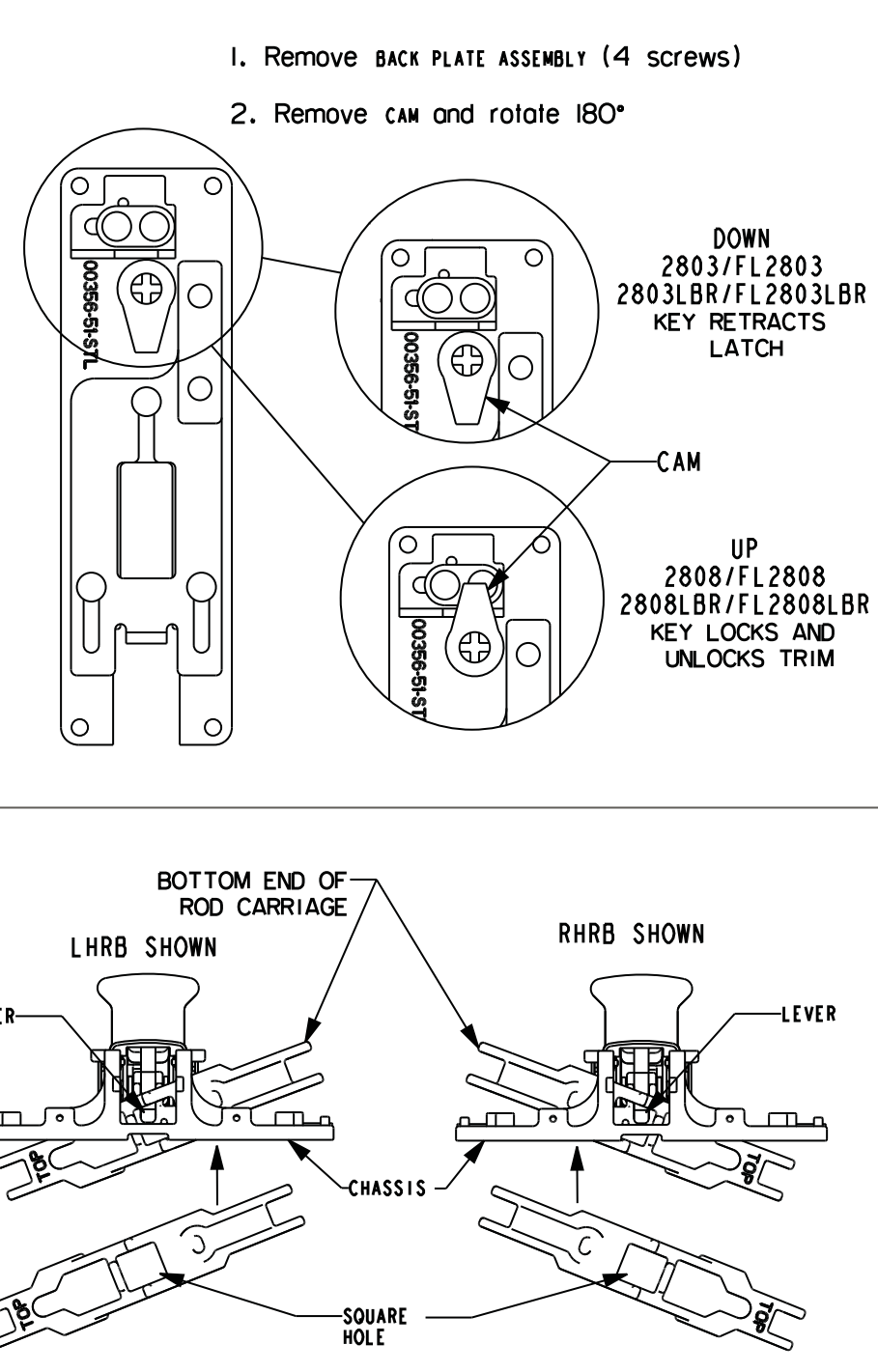

DEVICE PREPARATION

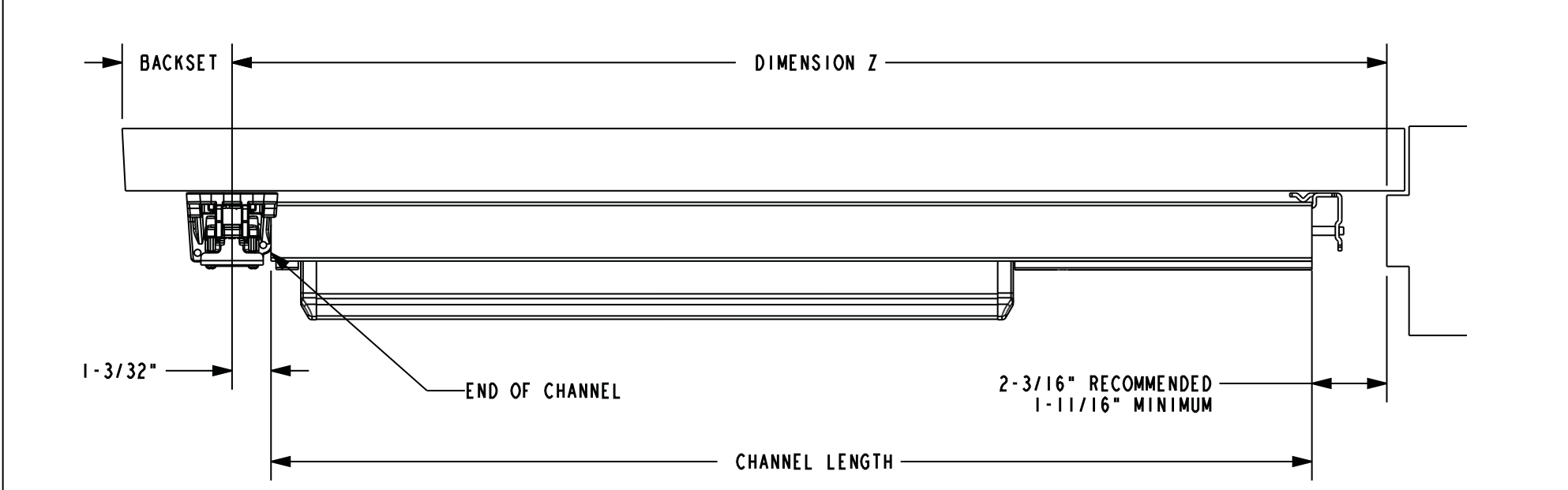

CUT DEVICE: - If Required
 1. Determine proper CHANNEL LENGTH by subtracting 3-1/4" from dimension Z.
 2. Mark cut off point (hinge side filler must be all the way inside of channel).
 3. Cut off channel and hinge side filler and deburr.

WARNING:
 If your device is equipped with ALK, CD, DE, or DS then please refer to instruction sheet listed below prior to cutting the device.

ALK	Alarm Kit	01639-11-000
CD	Cylinder Dogging	01725-11-000
DE	Delayed Egress	01844-11-000
DS	Door Position	02187-11-000

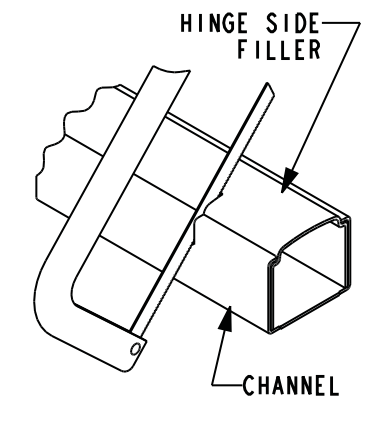

- CAUTION -
 PROTECT INSIDE OF DEVICE FROM METAL SHAVINGS

FIRE EXIT DEVICES SERIES FL2800 & FL2800LBR
 Sex bolts or through bolts are required for composite (Wood, Plastic and Steel covered), wood core, sheet metal and hollow metal doors without reinforcement unless door manufacturer has an alternate mounting method. Fire doors with steel reinforcement, mount devices with machine screws

NOTE:
 Fire rated device with less bottom rod applications must use FIRE BOLT

CONCEALED VERTICAL ROD EXIT DEVICE - REVERSIBLE
 SERIES 2800 , FL2800, 2800LBR & FL2800LBR

STANLEY
 DRWG DATE REVISION
 01769-11-000 09/2014 C
phi
 Precision Hardware
 a Division of Stanley Security Solutions, Inc.
 www.stanleysecuritysolutions.com

1 DOOR PREPARATION

1. Circle the TRIM NO. (if specified) at various locations (holes B and C) on the TRIM TEMPLATE.
 2. Mark HORIZONTAL CENTERLINE on inside face of door 39-15/16" from finished floor as shown. (Continue horizontal centerline to outside face of door if Trim is specified).
 3. Mark VERTICAL CENTERLINE per backset indicated at lock side on full height of door. (Mark vertical centerline at lock side using Backset dimension on outside face of door if Trim is specified).
- CAUTION: Vertical centerlines on both sides of the door should be the same dimension from the edge of the door.
4. Tape LOCK STILE CASE, TOP LATCH and BOTTOM LATCH Templates (and Trim Template if Trim specified) to the door so that the centerlines on the Template line up with centerlines on the door. Mark centers and drill the required holes as indicated on the templates.

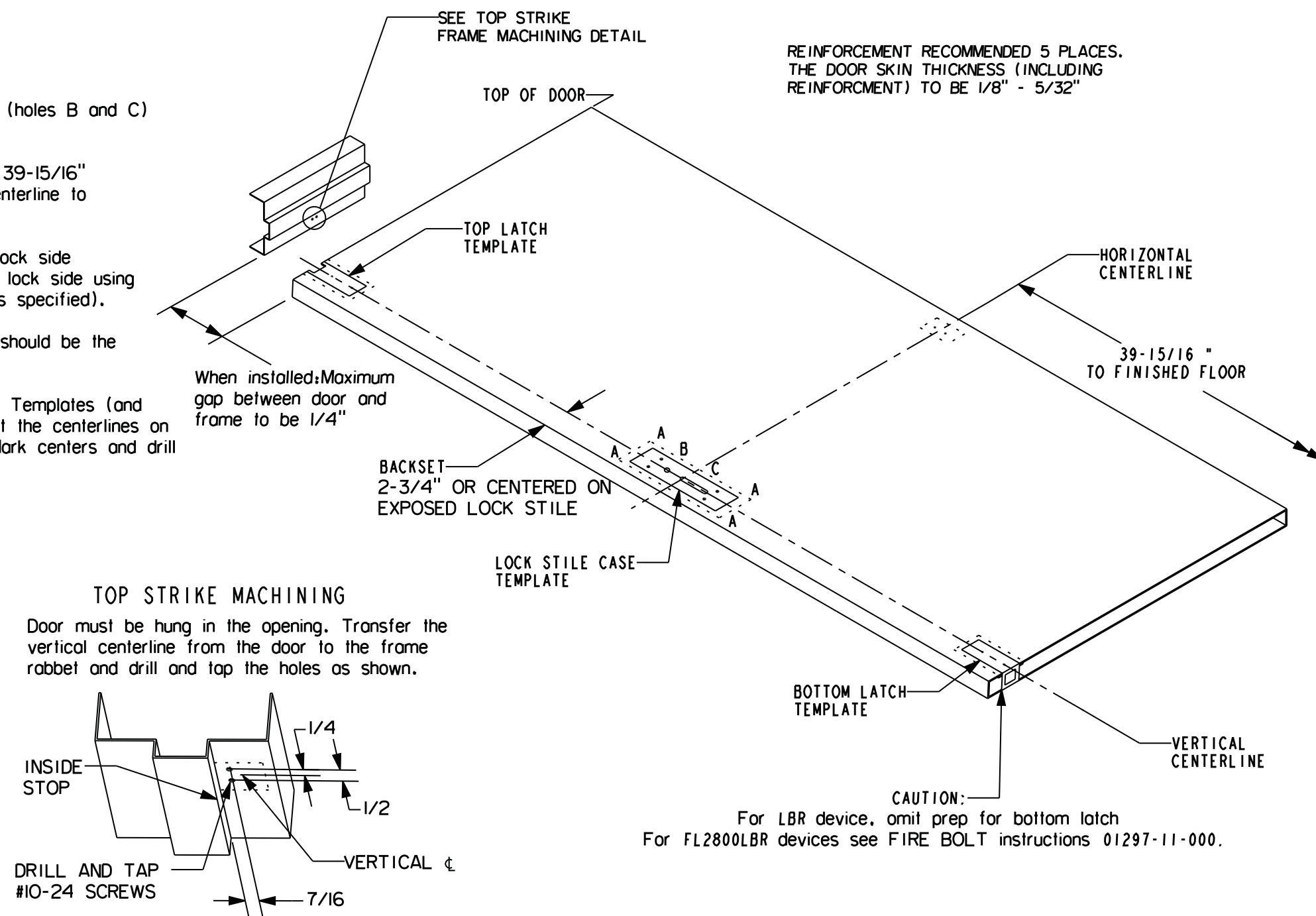

4 DEADLOCK/HOLDBACK ADJUSTMENT

DEADLOCK:
When latchbolt is fully extended, it should be in deadlock. Deadlocking does not allow the latchbolt to be pushed down.

HOLDBACK: (Latches held retracted)
Top latch should be in holdback when the touchbar is depressed and door is open. If device is in holdback, the latchbolt cannot be extended without rotating the latchbolt. Make sure bottom bolt clears the bottom strike.

TO ADJUST HOLDBACK / DEADLOCK
Holdback: If no holdback; turn top adjusting screw clockwise one half turn at a time and repeat if necessary.

Deadlock:
Rotate top latchbolt to extend fully; if it is not deadlocked. Turn top adjusting screw counter clockwise one half turn at a time and repeat if necessary.

TO ADJUST BOTTOM BOLT
Depress the touch bar, the device must be in holdback to gain access to adjusting screw. To increase clearance between bottom bolt and strike, turn the bottom adjusting screw clockwise. To decrease clearance between the bottom bolt and strike, turn counter clockwise.

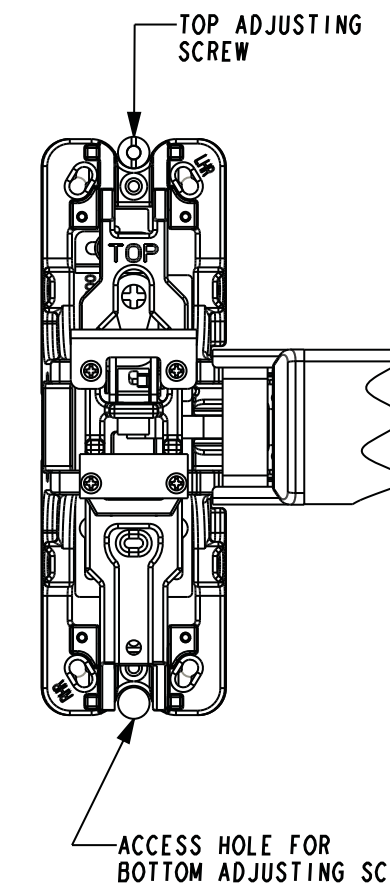

2 CVR ASSEMBLY & INSTALLATION

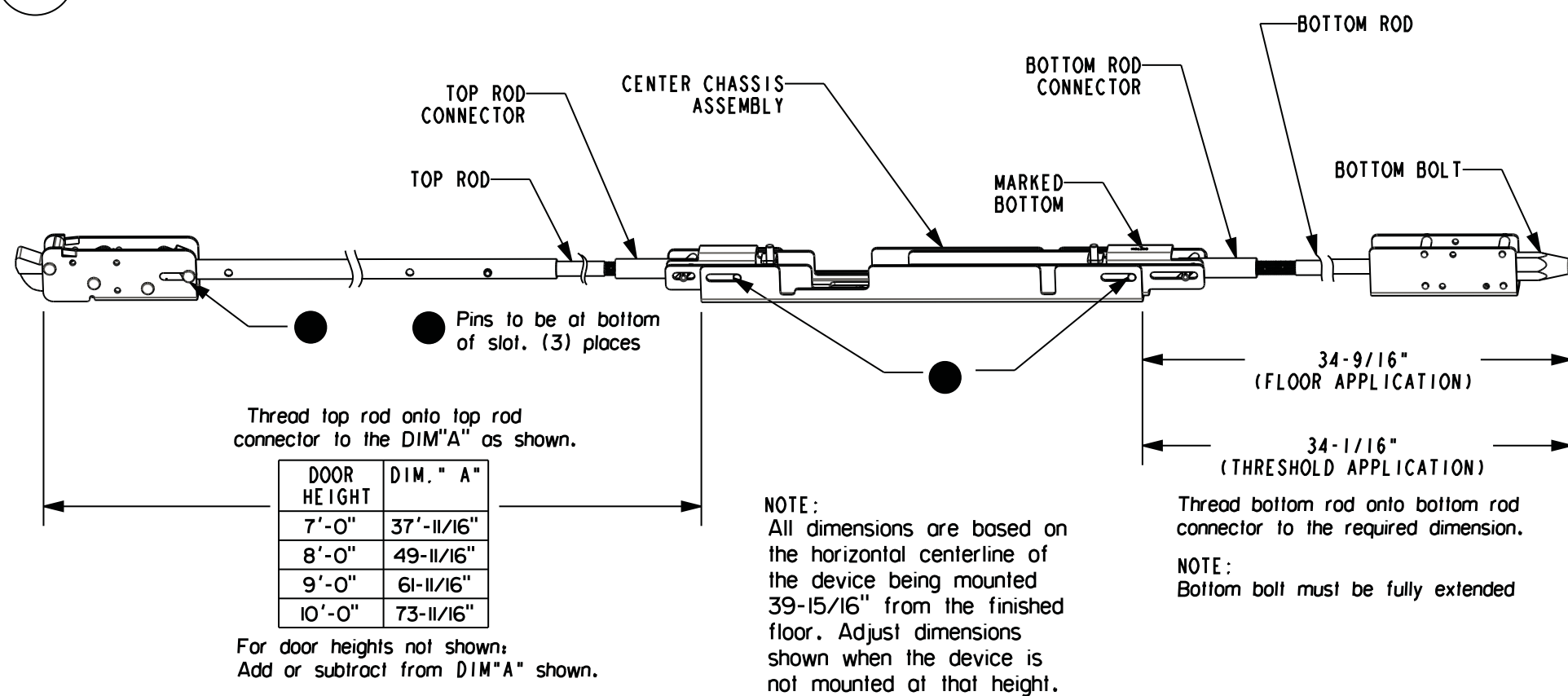

DOOR HEIGHT	DIM. " A "
7'-0"	37'-11/16"
8'-0"	49-11/16"
9'-0"	61-11/16"
10'-0"	73-11/16"

For door heights not shown: Add or subtract from DIM "A" shown.

BOTTOM BOLT APPLICATION

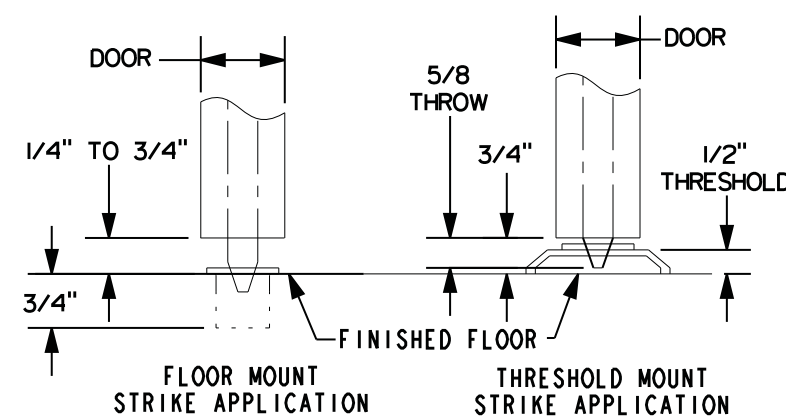

INSTALLATION

1. Insert Concealed Vertical Rod (CVR) assembly into the door through the hole in the top edge of door
2. Attach the CENTER CHASSIS to the door with two screws through "E" holes. (see Device Template)
3. Attach each latch to the door with two screws and finishing washers.

3 APPLY DEVICE

NOTE: If Trim is specified; see Trim instructions packaged with the trim. If the Exit Device has Electrical or other options see specific option instructions packaged in exit device carton.

1. LOCK STILE CASE mounting DEVICE WITH TRIM: See trim instructions. CYLINDER ONLY See O3 trim instructions
- Insert the ROD LIFT in the ROD LIFT SLOT and attach the LOCK STILE CASE to the CVR CENTER CHASSIS using the two screws at center of chassis and mount chassis to the door with four screws.

2. Insert the MOUNTING BRACKET into touch bar assembly tight against the channel. Level the device, mark and drill 2 holes for #10 sheet metal screws or #10-24 machine screws. Fasten the MOUNTING BRACKET to door and attach the ENDCAP to MOUNTING BRACKET with 2 screws.

3. Attach Top Strike to frame using two screws. NOTE: If there is an excessive clearance between the door and frame, apply the strike shim.

4. APPLY BOTTOM STRIKE
 - A. FOR FLOOR APPLICATION Center strike around bolt.
 - Mark floor for fasteners. Prepare floor for the type of fastener furnished. Provide clearance in floor for the bolt.
 - B. FOR THRESHOLD APPLICATION - Center strike around bolt.
 - Provide hole in threshold to accept the bolt. Mark threshold for fasteners. Prepare the threshold according to the type of fasteners furnished.

5. Attach cover to Lock Stile Chassis with 4 screws.

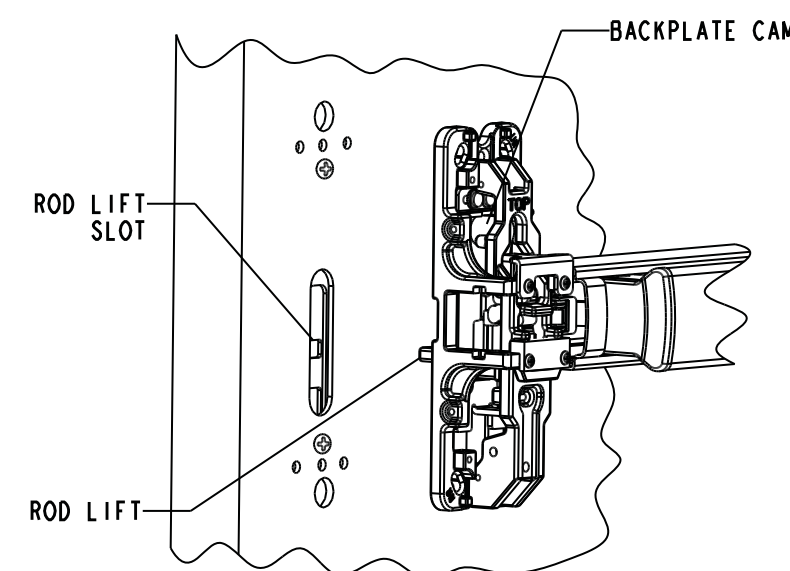

CAUTION
For C1715 and 4914 trim the lift must be unlocked. The cam will move locking slide away from lift to unlock.

