

INSTALLATION INSTRUCTIONS

RIM EXIT DEVICE
SERIES 2100 & FL2100 - REVERSIBLE

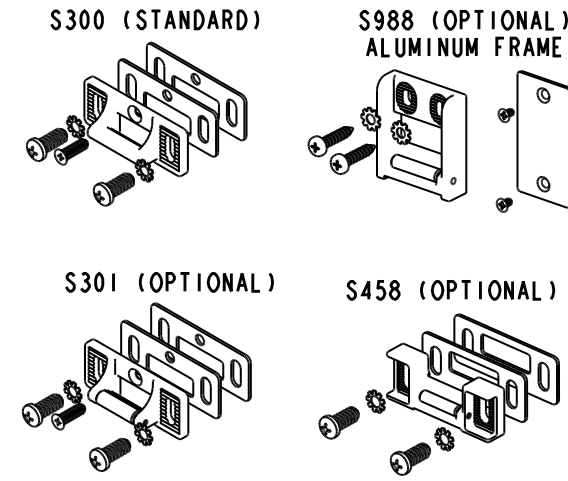
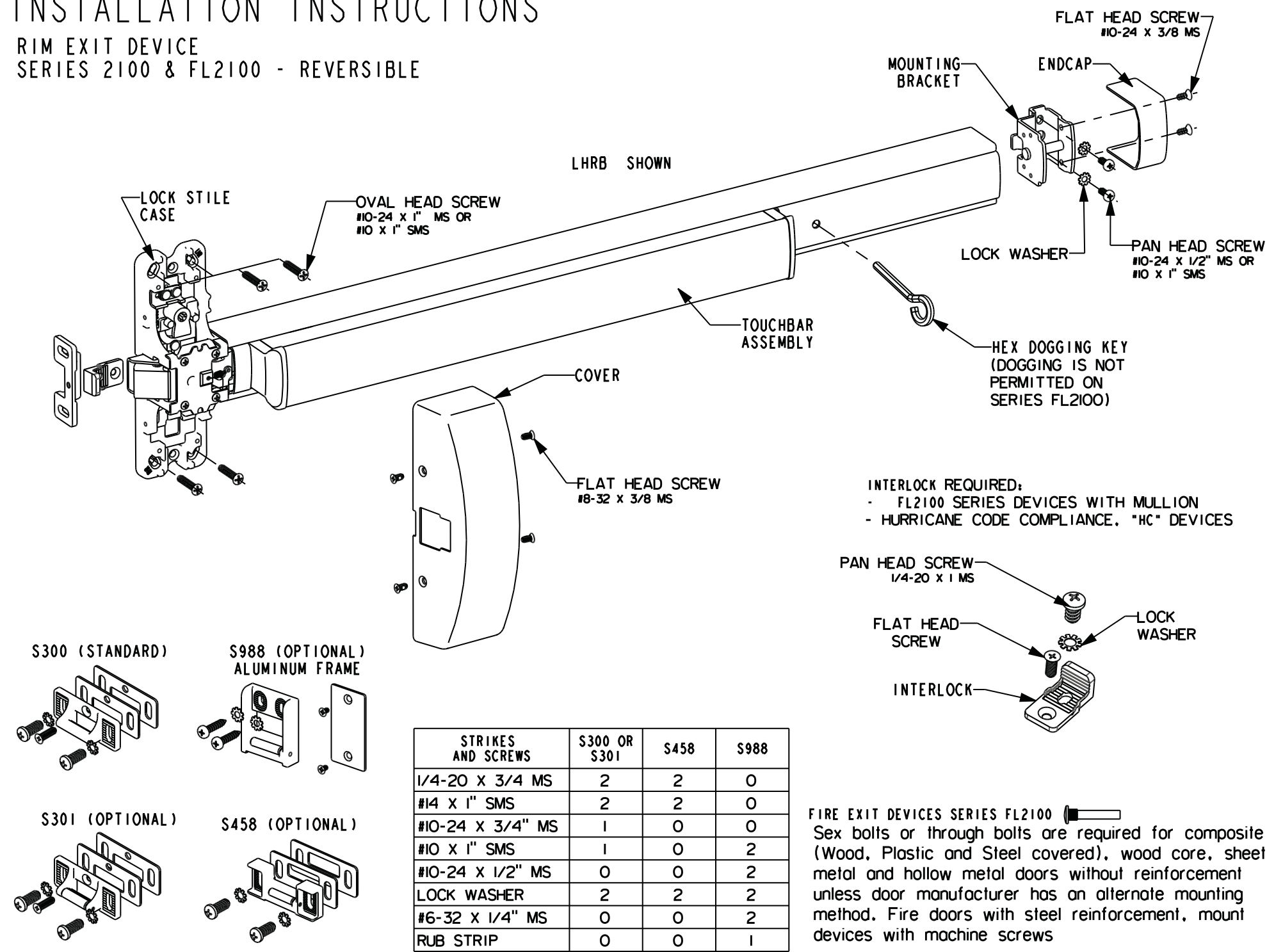

STRIKES AND SCREWS	S300 OR S301	S458	S988
1/4-20 X 3/4 MS	2	2	0
#14 X 1" SMS	2	2	0
#10-24 X 3/4" MS	1	0	0
#10 X 1" SMS	1	0	2
#10-24 X 1/2" MS	0	0	2
LOCK WASHER	2	2	2
#6-32 X 1/4" MS	0	0	2
RUB STRIP	0	0	1

INTERLOCK REQUIRED:
- FL2100 SERIES DEVICES WITH MULLION
- HURRICANE CODE COMPLIANCE, "HC" DEVICES

FIRE EXIT DEVICES SERIES FL2100
Sex bolts or through bolts are required for composite (Wood, Plastic and Steel covered), wood core, sheet metal and hollow metal doors without reinforcement unless door manufacturer has an alternate mounting method. Fire doors with steel reinforcement, mount devices with machine screws

1 DOOR PREPARATION

- Circle the following: STRIKE NUMBER, Dimension "X", and BACKSET in the chart below. TRIM NUMBER, (if specified) at various locations (holes B and C) on the TRIM TEMPLATE.
- Close door. Mark HORIZONTAL CENTERLINE on inside face of door and on lock side DOOR STOP 39-15/16" from finish floor as shown, or as required for the specific installation. (Continue horizontal centerline to outside face of door if trim is specified)
- Mark VERTICAL CENTERLINE at lock side using dimension "X". (If trim is specified mark vertical centerline on the outside face of door using backset dimension)
CAUTION: Vertical centerlines on both sides of the door should be the same dimension from the edge of the door.
- Tape Lock Stile Case Template (and Trim Template if Trim specified) to the door so that the centerlines on the template line up with centerlines on the door. Mark centers and drill the required holes as indicated on the templates.
- Fold Strike Template and place on door stop or mullion and inside face of door, so the horizontal centerline on template lines up with the horizontal centerline on door stop and door. Tape template on the door stop or mullion and the door face. Mark centers and drill holes as indicated on the template.

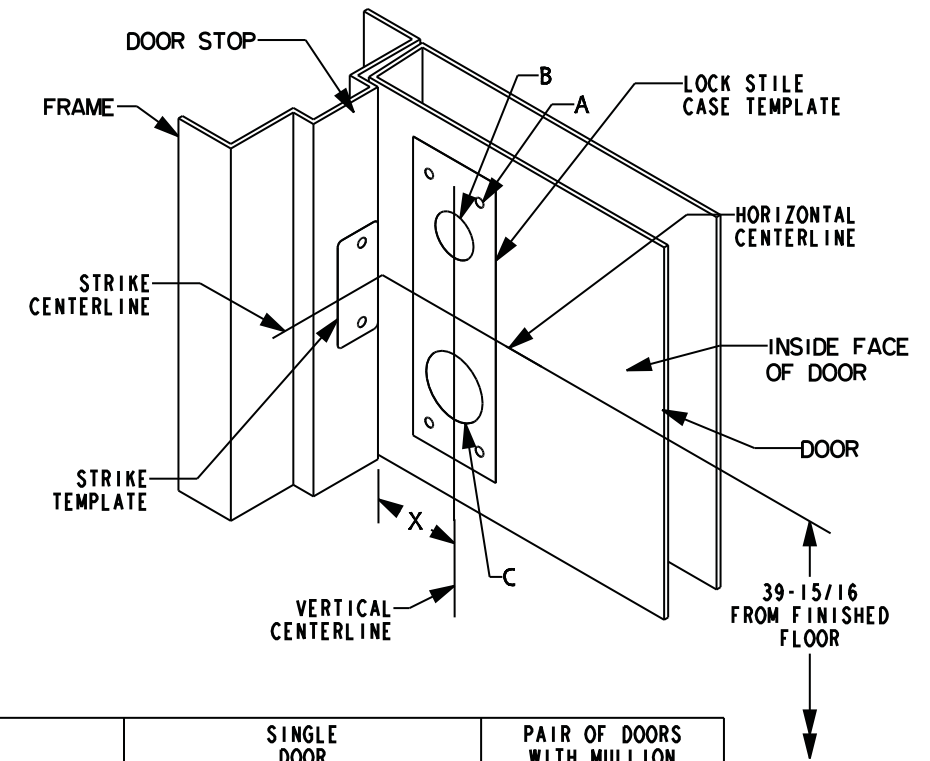

STRIKE No.	SINGLE DOOR			PAIR OF DOORS WITH MULLION	
	S300 S301	S458	S988 ALUMINUM	S300 S301	S458
DIMENSION X	2-1/4	2-1/16	2-1/16	2-1/4	2-1/16
BACKSET	2-3/4	2-9/16	1-15/16	3-1/8	2-15/16
STILE WIDTH	4-1/4 MIN	4 MIN	3-1/2 MIN	4-5/8 MIN	4-3/8 MIN

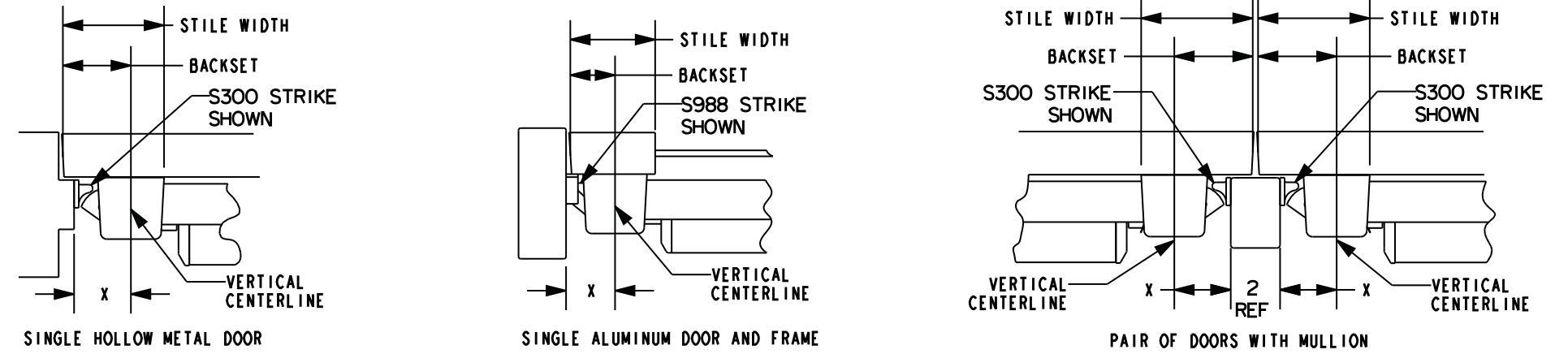

DEVICE PREPARATION

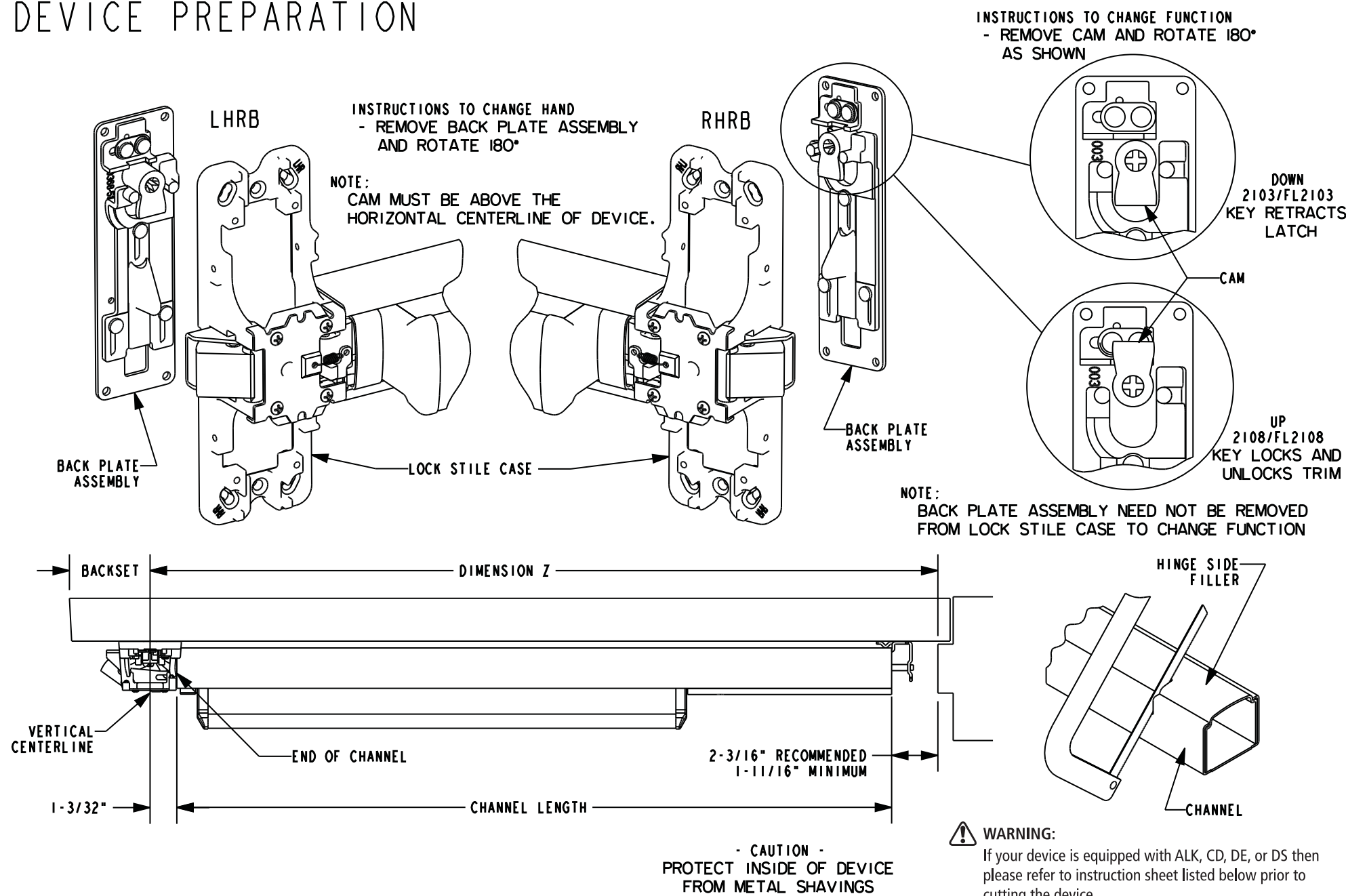

- CUT DEVICE: - If Required
- Determine proper CHANNEL LENGTH by subtracting 3 1/4" from dimension Z.
 - Mark cut off point (hinge side filler must be all the way inside of channel).
 - Cut off channel and hinge side filler and deburr.

WARNING:
If your device is equipped with ALK, CD, DE, or DS then please refer to instruction sheet listed below prior to cutting the device.

ALK	Alarm Kit	01639-11-000
CD	Cylinder Dogging	01725-11-000
DE	Delayed Egress	01844-11-000
DS	Door Position	02187-11-000

2 APPLY DEVICE

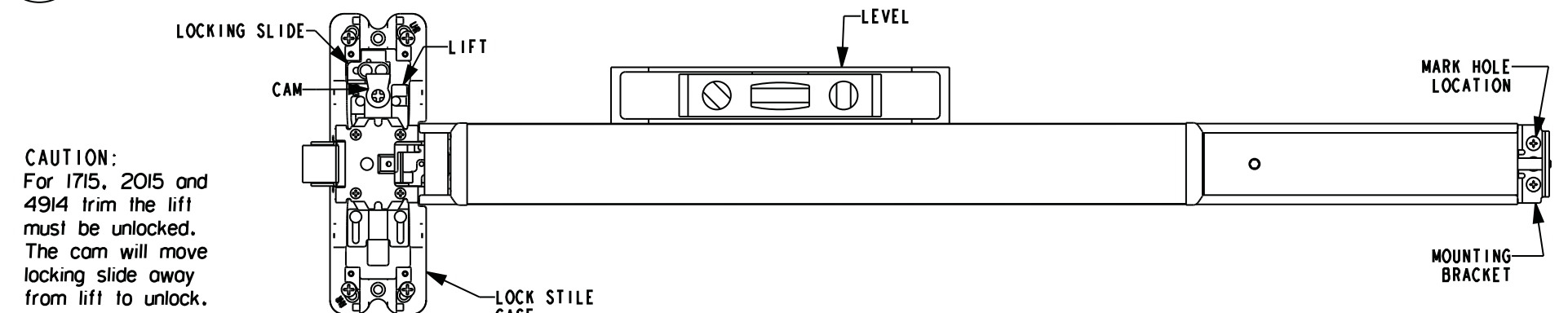

CAUTION:
For 1715, 2015 and 4914 trim the lift must be unlocked. The cam will move locking slide away from lift to unlock.

NOTE: If Trim is specified: See the Trim installation instructions packaged with the trim. If the Exit Device has Electrical or other options see specific option instructions in exit device carton.

- Lock Stile Case Mounting
DEVICE WITH TRIM - See Trim instructions
CYLINDER ONLY - Install cylinder with cylinder back plate as shown. Make sure the tailpiece is extending 1/2" to 7/8" from the inside face of door. Insert tailpiece into CAM in the lock stile case and mount it to the door with 4 screws.
EXIT ONLY - Mount Lock Stile Case to the door with 4 screws.
- Insert MOUNTING BRACKET into touch bar assembly tight against channel. Level device, mark and drill 2 holes for #10 sheet metal screws or #10-24 machine screws. Fasten MOUNTING BRACKET to door and attach ENDCAP with 2 screws.
- Fasten strike to frame and adjust strike so that the device latches tightly without binding. Strike shims are provided if excessive gap is apparent between latch and strike lip.
 - For S300 and S301 strikes apply third center screw once adjustment is complete.
 - For S988 strike apply rub strip to the aluminum frame as shown on instructions packaged with strike.
 - For FL with mullion and HC devices, install interlock by sliding it into slot under Lock Stile Case. Secure with screws and lock washer.
- Attach cover to lock stile case.

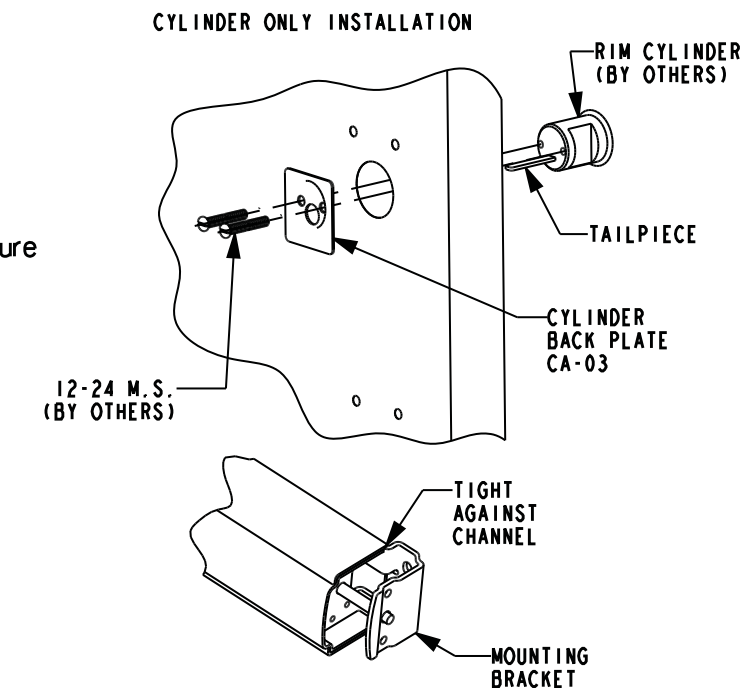

RIM EXIT DEVICE
SERIES 2100 & FL2100 - REVERSIBLE